

# Cummins Parts Catalog

## 6BTA5.9 F1, F2, F4

The pictures which follow show the locations of the major external engine components, the filters, and other service and maintenance points.

1. Terminal Box
2. Fuel Pump
3. Engine Dataplate
4. Coolant Pressure Cap
5. Instrument Panel
6. Air Cleaner
7. Coolant Heater
8. Starting Motor Contactors
9. Dipstick
10. Top Fill Tank
11. Fuel Filter
12. Lubricating Oil Fill Location
13. Oil Pan Drain
14. Speed Switch (located inside box)

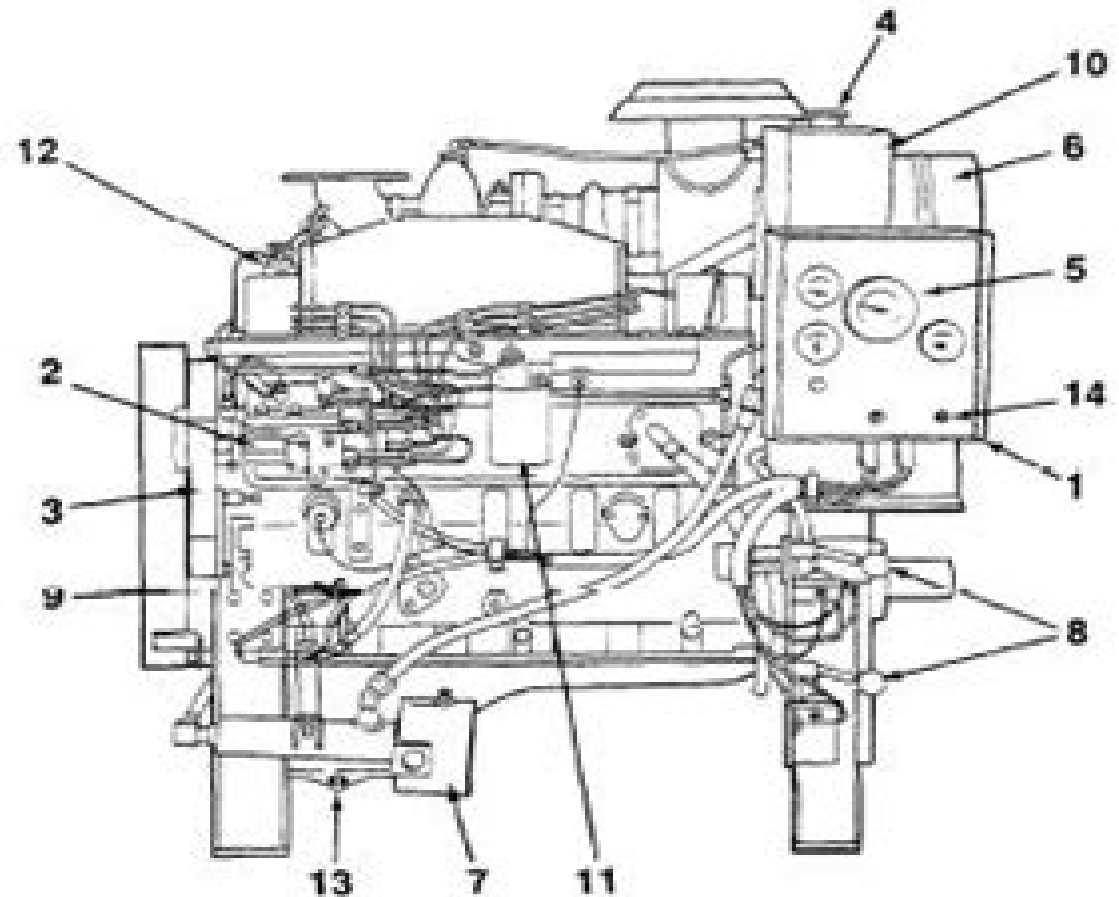

# Marine Cummins 6bta Service Manual

**EW Minium**



**Marine Cummins 6bta Service Manual:**

*National Fisherman* ,1989-05    **Boating** ,2000-01    **Atlantic Fisherman** ,1989    **The Waterways Journal** ,1987-04    **Cummins Troubleshooting and Repair Manual** Cummins Engine Company,1988    **Service Manual** ,2022

**U.S. Marine Corps Maintenance Manual, Ordnance** United States. Marine Corps,1959    Direct Support and General Support Maintenance Manual ,1987    Service Manual ,2022    *Direct Support and General Support Maintenance Manual Including Repair Parts and Special Tools List* ,1983    *Service Manual* ,2022    *Service Manual* ,2021    Direct and General Support Maintenance Manual (including Repair Parts and Special Tools List) ,1991    **Service Manual** ,2022

**Direct Support and General Support Maintenance Manual for** ,1985    **Direct Support and General Support Maintenance Manual Including Repair Parts and Special Tool List** ,1990    **Cummins Troubleshooting and Repair Manual** Cummins Engine Company,1988    **Direct Support and General Support Maintenance Manual (including Direct Support, and General Support Repair Parts List and Depot Maintenance Allowances) for Engine, Diesel, with Accessories, Cummins Model V8-300 (2815-910-8217).** ,1976    Troubleshooting and Repair Manual ,1985

**Operation and Maintenance Manual** ,2022

Fuel your quest for knowledge with is thought-provoking masterpiece, Dive into the World of **Marine Cummins 6bta Service Manual** . This educational ebook, conveniently sized in PDF ( Download in PDF: \*), is a gateway to personal growth and intellectual stimulation. Immerse yourself in the enriching content curated to cater to every eager mind. Download now and embark on a learning journey that promises to expand your horizons. .

<http://www.armchairempire.com/public/scholarship/HomePages/Healthy%20Instant%20Pressure%20Cooker%20Cookbook.pdf>

## **Table of Contents Marine Cummins 6bta Service Manual**

1. Understanding the eBook Marine Cummins 6bta Service Manual
  - The Rise of Digital Reading Marine Cummins 6bta Service Manual
  - Advantages of eBooks Over Traditional Books
2. Identifying Marine Cummins 6bta Service Manual
  - Exploring Different Genres
  - Considering Fiction vs. Non-Fiction
  - Determining Your Reading Goals
3. Choosing the Right eBook Platform
  - Popular eBook Platforms
  - Features to Look for in an Marine Cummins 6bta Service Manual
  - User-Friendly Interface
4. Exploring eBook Recommendations from Marine Cummins 6bta Service Manual
  - Personalized Recommendations
  - Marine Cummins 6bta Service Manual User Reviews and Ratings
  - Marine Cummins 6bta Service Manual and Bestseller Lists
5. Accessing Marine Cummins 6bta Service Manual Free and Paid eBooks
  - Marine Cummins 6bta Service Manual Public Domain eBooks
  - Marine Cummins 6bta Service Manual eBook Subscription Services

- Marine Cummins 6bta Service Manual Budget-Friendly Options
- 6. Navigating Marine Cummins 6bta Service Manual eBook Formats
  - ePub, PDF, MOBI, and More
  - Marine Cummins 6bta Service Manual Compatibility with Devices
  - Marine Cummins 6bta Service Manual Enhanced eBook Features
- 7. Enhancing Your Reading Experience
  - Adjustable Fonts and Text Sizes of Marine Cummins 6bta Service Manual
  - Highlighting and Note-Taking Marine Cummins 6bta Service Manual
  - Interactive Elements Marine Cummins 6bta Service Manual
- 8. Staying Engaged with Marine Cummins 6bta Service Manual
  - Joining Online Reading Communities
  - Participating in Virtual Book Clubs
  - Following Authors and Publishers Marine Cummins 6bta Service Manual
- 9. Balancing eBooks and Physical Books Marine Cummins 6bta Service Manual
  - Benefits of a Digital Library
  - Creating a Diverse Reading Collection Marine Cummins 6bta Service Manual
- 10. Overcoming Reading Challenges
  - Dealing with Digital Eye Strain
  - Minimizing Distractions
  - Managing Screen Time
- 11. Cultivating a Reading Routine Marine Cummins 6bta Service Manual
  - Setting Reading Goals Marine Cummins 6bta Service Manual
  - Carving Out Dedicated Reading Time
- 12. Sourcing Reliable Information of Marine Cummins 6bta Service Manual
  - Fact-Checking eBook Content of Marine Cummins 6bta Service Manual
  - Distinguishing Credible Sources
- 13. Promoting Lifelong Learning
  - Utilizing eBooks for Skill Development
  - Exploring Educational eBooks
- 14. Embracing eBook Trends

- Integration of Multimedia Elements
- Interactive and Gamified eBooks

## **Marine Cummins 6bta Service Manual Introduction**

In this digital age, the convenience of accessing information at our fingertips has become a necessity. Whether its research papers, eBooks, or user manuals, PDF files have become the preferred format for sharing and reading documents. However, the cost associated with purchasing PDF files can sometimes be a barrier for many individuals and organizations. Thankfully, there are numerous websites and platforms that allow users to download free PDF files legally. In this article, we will explore some of the best platforms to download free PDFs. One of the most popular platforms to download free PDF files is Project Gutenberg. This online library offers over 60,000 free eBooks that are in the public domain. From classic literature to historical documents, Project Gutenberg provides a wide range of PDF files that can be downloaded and enjoyed on various devices. The website is user-friendly and allows users to search for specific titles or browse through different categories. Another reliable platform for downloading Marine Cummins 6bta Service Manual free PDF files is Open Library. With its vast collection of over 1 million eBooks, Open Library has something for every reader. The website offers a seamless experience by providing options to borrow or download PDF files. Users simply need to create a free account to access this treasure trove of knowledge. Open Library also allows users to contribute by uploading and sharing their own PDF files, making it a collaborative platform for book enthusiasts. For those interested in academic resources, there are websites dedicated to providing free PDFs of research papers and scientific articles. One such website is Academia.edu, which allows researchers and scholars to share their work with a global audience. Users can download PDF files of research papers, theses, and dissertations covering a wide range of subjects. Academia.edu also provides a platform for discussions and networking within the academic community. When it comes to downloading Marine Cummins 6bta Service Manual free PDF files of magazines, brochures, and catalogs, Issuu is a popular choice. This digital publishing platform hosts a vast collection of publications from around the world. Users can search for specific titles or explore various categories and genres. Issuu offers a seamless reading experience with its user-friendly interface and allows users to download PDF files for offline reading. Apart from dedicated platforms, search engines also play a crucial role in finding free PDF files. Google, for instance, has an advanced search feature that allows users to filter results by file type. By specifying the file type as "PDF," users can find websites that offer free PDF downloads on a specific topic. While downloading Marine Cummins 6bta Service Manual free PDF files is convenient, its important to note that copyright laws must be respected. Always ensure that the PDF files you download are legally available for free. Many authors and publishers voluntarily provide free PDF versions of their work, but its essential to be cautious and verify the authenticity of the source before downloading Marine Cummins 6bta Service Manual. In

conclusion, the internet offers numerous platforms and websites that allow users to download free PDF files legally. Whether its classic literature, research papers, or magazines, there is something for everyone. The platforms mentioned in this article, such as Project Gutenberg, Open Library, Academia.edu, and Issuu, provide access to a vast collection of PDF files. However, users should always be cautious and verify the legality of the source before downloading Marine Cummins 6bta Service Manual any PDF files. With these platforms, the world of PDF downloads is just a click away.

### **FAQs About Marine Cummins 6bta Service Manual Books**

How do I know which eBook platform is the best for me? Finding the best eBook platform depends on your reading preferences and device compatibility. Research different platforms, read user reviews, and explore their features before making a choice. Are free eBooks of good quality? Yes, many reputable platforms offer high-quality free eBooks, including classics and public domain works. However, make sure to verify the source to ensure the eBook credibility. Can I read eBooks without an eReader? Absolutely! Most eBook platforms offer web-based readers or mobile apps that allow you to read eBooks on your computer, tablet, or smartphone. How do I avoid digital eye strain while reading eBooks? To prevent digital eye strain, take regular breaks, adjust the font size and background color, and ensure proper lighting while reading eBooks. What the advantage of interactive eBooks? Interactive eBooks incorporate multimedia elements, quizzes, and activities, enhancing the reader engagement and providing a more immersive learning experience. Marine Cummins 6bta Service Manual is one of the best book in our library for free trial. We provide copy of Marine Cummins 6bta Service Manual in digital format, so the resources that you find are reliable. There are also many Ebooks of related with Marine Cummins 6bta Service Manual. Where to download Marine Cummins 6bta Service Manual online for free? Are you looking for Marine Cummins 6bta Service Manual PDF? This is definitely going to save you time and cash in something you should think about.

### **Find Marine Cummins 6bta Service Manual :**

[healthy instant pressure cooker cookbook](#)

**haynes repair manual saturn**

~~health care operations management health care operations management~~

**he hilosophers ay 4th dition hapter 1 ohn haffee**

[heart of compassion the vocation of woman today](#)

*hcs 2015 user guide*

**healing evangelism strengthen your witnessing with effective prayer for the sick**

healthcare strategy in pursuit of competitive advantage

**healing gods forgotten gift study companion**

heartsaver cpr guide 2015

*hazardous materials for fire and explosion investigators guidelines and procedures*

healing the wounds of a fatherless generation

**hds 601 c eco manual**

**hayward swim pro filter manual**

haynes workshop manual peugeot

**Marine Cummins 6bta Service Manual :**

**physics for scientists and engineers volume 1 9th edition** - Feb 28 2023

web serway is the coauthor of college physics eleventh edition physics for scientists and engineers ninth edition principles of physics fifth

**physics for scientists and engineers volume 2 9th** - Jun 22 2022

web study guide with student solutions manual volume 2 for serway jewett s physics for scientists and engineers 9th İngilizce baskı raymond a serway ve john w jewett

**physics for scientists and engineers with modern** - Feb 16 2022

**serway jewett physics for scientists and engineers with** - Jun 03 2023

web free pdf serway jewett physics for scientists and engineers with modern physics 9th ed

physics for scientists and engineers with modern physics - Nov 27 2022

web physics for scientists and engineers with modern physics 9th edition author s raymond a serway john w jewett publisher cengage learning format fixed

webassign physics for scientists and engineers 9th edition - Jul 24 2022

web physics 9th ed serway jewett author serway jewett language english region format pdf pages 1622 file size 53 1 mb total download 236

*download physics 9th ed serway jewett pdf oiipdf com* - Apr 20 2022

web serway r a and jewett j w 2014 physics for scientists and engineers with modern physics 9th edition cengage learning boston has been cited by the following article



**physics for scientists and engineers with modern physics 9th** - Sep 25 2022

web the webassign content for physics for scientists and engineers 9 e by serway and jewett includes an extensive bank of more than 6 500 questions including end of

**serway r a and jewett j w 2014 physics for scientists and** - Dec 17 2021

physics for scientists and engineers raymond a serway john - Jan 30 2023

web in addition to physics for scientists and engineers dr serway is the coauthor of principles of physics fifth edition college physics ninth edition

*physics for scientists and engineers with modern physics* - Aug 25 2022

web authors raymond a serway john w jewett isbn 13 978 1133947271 see our solution for question 1 from chapter 1 from physics for scientists and engineers by serway and

physics for scientists and engineers with modern - May 02 2023

web jan 17 2013 physics for scientists and engineers with modern physics 9th edition by raymond a serway author john w jewett author 4 5 132 ratings see all formats

*physics for scientists and engineers 9th edition quizlet* - Aug 05 2023

web find step by step solutions and answers to physics for scientists and engineers 9781133947271 as well as thousands of textbooks so you can move forward with

**physics for scientists and engineers 9th edition prepscholar** - May 22 2022

web serway jewett physics 9th edition copy esource svb serway jewett physics 9th edition 1 serway jewett physics 9th edition physics for global scientists and

**amazon com tr serway jewett kitap** - Mar 20 2022

web happy that we coming again the further heap that this site has to definite your curiosity we find the money for the favorite serway and jewett physics 9th photograph album as

**physics for scientists and engineers serway raymond** - Dec 29 2022

web physics for scientists and engineers incorporates the serway jewett hallmarks of concise writing and carefully thought out problem sets while integrating an

**download ebook serway and jewett physics 9th edition** - Nov 15 2021

the leading provider of higher education course materials - Oct 27 2022

web jan 1 2018 raymond a serway john w jewett cengage learning jan 1 2018 mathematics 1484 pages achieve success in

your physics course by making the most

*serway jewett physics for scientists and engineers with* - Sep 06 2023

web dec 9 2018 serway jewett physics for scientists and engineers with modern physics 9ed free download borrow and streaming internet archive topics

*physics 9th ed serway jewett pdf 53 08 mb pdf room* - Oct 07 2023

web feb 28 2021 physics 9th ed serway jewett free pdf download serway jewett 1 622 pages year 2013 physics read online pdf room

**physics for scientists and engineers by serway** - Apr 01 2023

web jan 1 2018 physics for scientists and engineers raymond a serway john w jewett cengage learning jan 1 2018

mathematics 1296 pages achieve success in your

**physics for scientists and engineers 9th edition cengage** - Jul 04 2023

web hardcopy textbook for serway jewett s physics for scientists and engineers buy direct for hassle free returns included in cengage unlimited

serway jewett physics 9th edition copy esource svb - Jan 18 2022

pdf the mauser m91 through m98 bolt actions a shop - Apr 29 2022

web jan 1 1990 a detailed book which is extremely practical for every level of gunsmithing knowledge this manual covers the 1911 from the lanyard loop to the barrel bushing

**the u s m1911 m1911a1 pistols and commercial m1911 type** - Oct 24 2021

the mauser m91 through m98 bolt actions a shop manual - Aug 02 2022

web the s w revolver a shop manual vsp publishers 1990 paperback 8vo very good item 73665 153pp text unmarked to crisp white pages full of b w photos binding

*the colt 45 automatic a shop manual volume 1 by* - Dec 06 2022

web may 11 2016 jerry kuhnhausen s 1911 shop manual 8596 views 27 replies 22 participants last post by libertexan may 13 2016 jump to latest a acpie360

jerry kuhnhausen the us m 1911 m 1911 a 1 pistols a shop - Mar 29 2022

web jan 1 1997 with kuhnhausen s original volume 1 and the new volume 2 you have in hand more practical m1911 info tech data than ever before published in the entire

the colt 45 automatic a shop manual kuhnhausen jerry - Nov 24 2021

[jerry kuhnhausen abebooks](#) - Jan 07 2023

web jerry kuhnhausen publication date 1991 topics gunsmithing firearms gun rifle manual shop manual collection manuals contributions manuals additional collections shop

**the s w revolver a shop manual jerry kuhnhausen** - Feb 25 2022

web product overview the expanded 5th edition covers the traditional prewar post war s w hand ejector models and basically traditional s w numbered models made through

**home heritage gun books** - May 11 2023

web midwayusa is proud to offer the following shop manuals by jerry kuhnhausen the colt 45 automatic the u s m1911 1911a1 the colt single actions revolvers

**amazon com jerry kuhnhausen books** - Jul 13 2023

web jan 1 1990 jerry kuhnhausen s book the s w revolver a shop manual is an exceptionally detailed book on the j k l and n frame s w revolver actions whew

**the s w revolver a shop manual covers the s w j** - Mar 09 2023

web jerry kuhnhausen has 48 books on goodreads with 153 ratings jerry kuhnhausen s most popular book is colt 45 automatic a shop manual

**amazon com jerry kuhnhausen shop manuals books** - Aug 14 2023

web heritage gun books publishes and distributes the world s best gunsmithing manuals the jerry kuhnhausen vsp gunsmithing gun repair and gun rebuilding manuals

*jerry kuhnhausen shop manual by helenmcgee3835 issuu* - Jan 27 2022

**jerry kuhnhausen the us m 1911 m 1911 a 1 pistols** - Jun 12 2023

web the 45 automatic new expanded 10th edition volume 1 jerry kuhnhausen shop manual series volume 1 10th edition

**books by jerry kuhnhausen author of colt 45 automatic** - Oct 04 2022

web oct 28 2022 a shop manual by jerry kuhnhausen in pdf format complete free brief summary of book the mauser m91 through m98 bolt actions a shop manual by

**jerry kuhnhausen 1911 shop manual pdf** - Dec 26 2021

[jerry kuhnhausen manuals artisan ideas](#) - Sep 03 2022

web note many internet archive torrents contain a pad file directory this directory and the files within it may be erased once retrieval completes note the file jerry kuhnhausen the us

**jerry kuhnhausen s 1911 shop manual 1911forum** - Jul 01 2022

web aug 8 2017 get jerry kuhnhausen shop manual pdf file for free from our online library related pdfs for jerry kuhnhausen shop manual jerry kuhnhausen shop

*the s w revolvers a shop manual new expanded 5th* - Feb 08 2023

web the colt 45 automatic vol 1 dvd gunsmithing the colt 45 auto m1911 m1911a1 book dvd by j kuhnhausen price 65 90 quantity add to cart the colt 45

the colt single action revolvers a shop manual volumes i ii - Nov 05 2022

web mar 7 2022 go to parent directory ia thumb jpg 21 jul 2022 03 29 16 7k jerry kuhnhausen the us m 1911 m 1911 a 1 pistols a shop manual heritage gun books

**amazon com jerry kuhnhausen shop manuals** - Apr 10 2023

web bibliographic information title the colt single action revolvers a shop manual volumes i ii author jerry kuhnhausen editor noel kuhnhausen publisher heritage gun

**the s w revolver a shop manual 5th edition by jerry** - Sep 22 2021

*jerry kuhnhausen the us m 1911 m 1911 a 1 pistols a shop* - May 31 2022

web m type pistols a shop manual volume 2 by jerry kuhnhausen a shop manual volume 1 in the kuhnhausen m pistol series jerry kuhnhausen mk iv series 80

*worst case michael bennett 3 band 3 mass market* - Nov 24 2021

*worst case a michael bennett thriller book 3 kindle edition* - Oct 24 2021

**worst case michael bennett 3 band 3 amazon de** - Dec 26 2021

worst case a michael bennett thriller 3 mitpressbookstore - Oct 04 2022

web hello sign in account lists returns orders cart

*michael bennett worst case series 3 hardcover* - Nov 05 2022

web select the department you want to search in

amazon com customer reviews worst case a michael bennett - Sep 03 2022

web buy worst case michael bennett 3 one wrong answer will cost you your life by patterson james from amazon s fiction books store everyday low prices on a huge

*worst case michael bennett band 3 uniport edu - Mar 29 2022*

web *worst case michael bennett 3 band 3 patterson james ledwidge michael amazon de books*

**worst case michael bennett 3 patterson james amazon com tr - May 11 2023**

web apr 2 2013 *worst case michael bennett 3 band 3 patterson james ledwidge michael amazon de books*

*worst case michael bennett 3 one wrong answer will cost you - May 31 2022*

web *worst case michael bennett band 3 by james patterson michael ledwidge twenty five years including kiss the girls and along came a spider he writes full time and*

*worst case michael bennett 3 by james patterson - Jun 12 2023*

web *worst case michael bennett band 3 patterson james ledwidge michael cannavale bobby amazon de books*

*worst case michael bennett band 3 by james patterson michael - Feb 25 2022*

web *worst case michael bennett 3 band 3 patterson james ledwidge michael amazon de books*

*worst case michael bennett 3 one wrong answer will - Dec 06 2022*

web find helpful customer reviews and review ratings for *worst case a michael bennett thriller 3* at amazon com read honest and unbiased product reviews from our users

**worst case michael bennett band 3 by james patterson michael - Apr 29 2022**

web discover and share books you love on goodreads

*worst case michael bennett 3 amazon com tr - Aug 14 2023*

web *worst case michael bennett 3 patterson james amazon com tr kitap Çerez tercihlerinizi seçin Çerez bildirimimizde detaylandırıldığı üzere satın alım yapmanızı*

*worst case michael bennett 3 amazon com au - Aug 02 2022*

web *worst case michael bennett band 3 by james patterson michael ledwidge street and held hostage his parents can t save him because this kidnapper isn t demanding money*

*loading interface goodreads - Jan 27 2022*

web apr 2 2010 *worst case a michael bennett thriller book 3 kindle edition alex cross has washington d c the women s murder club has san francisco detective michael*

**worst case michael bennett 3 band 3 amazon de - Feb 08 2023**

web *worst case death detective michael bennett leads the investigation with ten kids of his own he can t begin to understand what could lead someone to target anyone s children*

*worst case michael bennett series 3 by james patterson - Jan 07 2023*

web aug 6 2013 *when another student from a powerful family disappears the fbi sends in its top abduction specialist agent*

emily parker bennett s job and love life suddenly get

**worst case michael bennett band 3 amazon de** - Mar 09 2023

web one wrong answer means death the son of one of new york s wealthiest families is snatched off the street his parents can t save him because this kidnapper isn t

**worst case a michael bennett thriller 3 amazon com** - Jul 13 2023

web worst case michael bennett 3 patterson james amazon com tr Çerez tercihlerinizi seçin alışveriş deneyiminizi geliştirmek hizmetlerimizi sunmak müşterilerin

*worst case michael bennett 3 amazon com au* - Jul 01 2022

web may 13 2023 hundreds times for their favorite novels like this worst case michael bennett band 3 but end up in harmful downloads rather than enjoying a good book

**worst case michael bennett 3 one wrong answer will** - Apr 10 2023

web feb 1 2010 new york detective michael bennett is an ace profiler who enjoys working alone and when a beautiful young fbi abduction specialist named emily parker is