

# Drive Assembly diagram 2

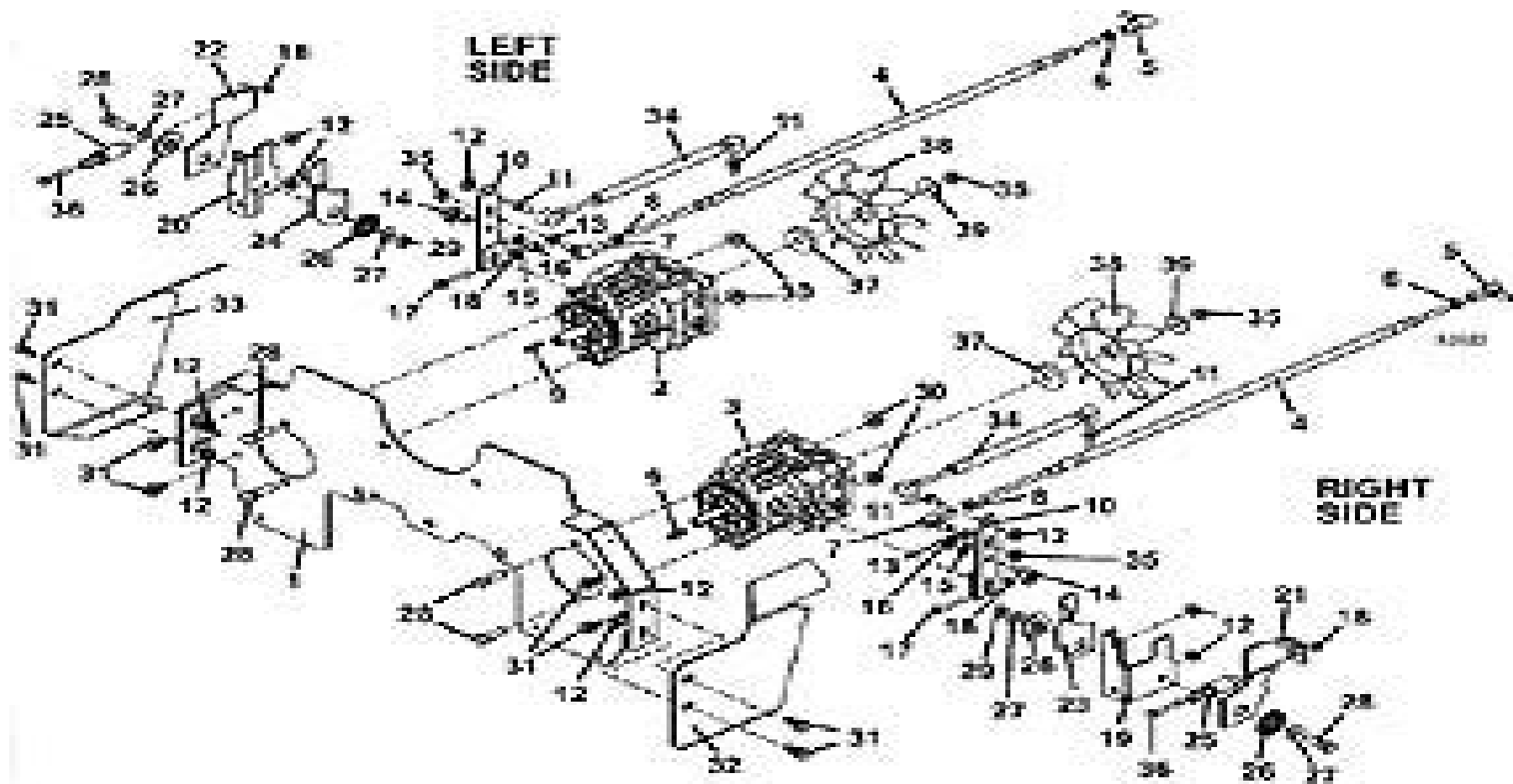

# Grasshopper Model 227 Manual

**Anthony S. Fauci**



## **Grasshopper Model 227 Manual:**

A Manual of the Grasshoppers of New Mexico David Bruce Richman, **BIOMAT 2007** Rubem Mondaini, 2008 The present volume contains the contributions of the keynote speakers of the BIOMAT 2007 Symposium as well as selected contributed papers in the areas of mathematical biology biological physics biophysics and bioinformatics It contains new results on some aspects of Lotka Volterra equations the proposal of using differential geometry to model neurosurgical tools recent data on epidemiological modeling pattern recognition and comprehensive reviews on the structure of proteins the folding problem and the influence of Allee effects on population dynamics This book contains some original results on the growth of gliomas the role played by membrane channels on activity dependent modulation of spike transmission a proposal for reconsidering the concept of gene and the understanding of the mechanisms responsible for gene expression a differential geometric approach to the influence of the drying effect on the dynamics of pods of Leguminosae the comparison of agent based models with the approach of differential equations on the study of selection mechanisms in germinal centers and the synchronization phenomenon for protocell systems driven by linear kinetic equations A Manual of Machinery and Millwork W. J. M. Rankine, 1883 **General Technical Report RM.** , 1981 *Analysis of Forage Production for Assessments and Appraisals* John Edward Mitchell, 1983 Second and Third Grade Manual Emma Miller Bolenius, 1923 A Manual of Marine Engineering Albert Edward Seaton, 1895 A Manual of the Vertebrate Animals of the Northern United States David Starr Jordan, 1894 **The Manual of Child Development** , 1927 *California Grasslands* Mark R. Stromberg, Jeffrey D. Corbin, Carla D'Antonio, 2007-12-03 This highly synthetic and scholarly work brings together new and important scientific contributions by leading experts on a rich diversity of topics concerning the history ecology and conservation of California s endangered grasslands The editors and authors have succeeded admirably in drawing from a great wealth of recent research to produce a widely accessible and compelling state of the art treatment of this fascinating subject Anyone interested in Californian biodiversity or grassland ecosystems in general will find this book to be an invaluable resource and a major inspiration for further research management and restoration efforts Bruce G Baldwin W L Jepson Professor and Curator UC Berkeley Grasses and grasslands are among the most important elements of the California landscape This is their book embodying the kind of integrated view needed for all ecological communities in California Approaches ranging across an incredibly broad spectrum paleontology and human history basic science and practical management techniques systematics community ecology physiology and genetics physical factors such as water soil nutrients atmospheric and fire biological factors such as competition symbiosis and grazing are nicely tied together due to careful editorial work This is an indispensable reference for everyone interested in the California environment Brent Mishler Director of the University Jepson Herbaria and Professor of Integrative Biology UC Berkeley The structure and function of California grasslands have intrigued ecologists for decades The editors of this volume have assembled a comprehensive set of

reviews by a group of outstanding authors on the natural history structure management and restoration of this economically and ecologically important ecosystem Scott L Collins Professor of Biology University of New Mexico

**Experiment Station Record** United States. Office of Experiment Stations,1939

**Experiment Station Record** U.S. Office of Experiment Stations,United States. Agricultural Research Service,United States. Office of Experiment Stations,1947

**Musical Times and Singing Class Circular** ,1916

**Dominion Experimental Farms in ...** Canada. Dominion Experimental Farms,1897

Report of the Dominion Experimental Farms Canada. Experimental Farms Service,1897

*Sessional Papers of the Dominion of Canada* Canada. Parliament,1897

Report of the Dominion fishery commission on the fisheries of the province of Ontario 1893 issued as vol 26 no 7 supplement

**Report of the Dominion Experimental Farms** Canada. Dept. of Agriculture. Experimental Farms,1896

**Reports** Canada. Experimental Farms,1896

**Structures and Architecture** Paulo J. Cruz,2016-10-14

Although the disciplines of architecture and structural engineering have both experienced their own historical development their interaction has resulted in many fascinating and delightful structures To take this interaction to a higher level there is a need to stimulate the inventive and creative design of architectural structures and to persuade architects and structural engineers to further collaborate in this process exploiting together new concepts applications and challenges This set of book of abstracts and full paper searchable CD ROM presents selected papers presented at the 3rd International Conference on Structures and Architecture Conference ICOSA2016 organized by the School of Architecture of the University of Minho Guimar es Portugal July 2016 to promote the synergy in the collaboration between the disciplines of architecture and structural engineering

American Bee Journal ,1917 Includes summarized reports of many bee keeper associations

Ignite the flame of optimism with its motivational masterpiece, Find Positivity in **Grasshopper Model 227 Manual** . In a downloadable PDF format ( \*), this ebook is a beacon of encouragement. Download now and let the words propel you towards a brighter, more motivated tomorrow.

[http://www.armchairempire.com/public/publication/Download\\_PDFS/Heart\\_Of\\_The\\_Message\\_Of\\_Medjugorje.pdf](http://www.armchairempire.com/public/publication/Download_PDFS/Heart_Of_The_Message_Of_Medjugorje.pdf)

## **Table of Contents Grasshopper Model 227 Manual**

1. Understanding the eBook Grasshopper Model 227 Manual
  - The Rise of Digital Reading Grasshopper Model 227 Manual
  - Advantages of eBooks Over Traditional Books
2. Identifying Grasshopper Model 227 Manual
  - Exploring Different Genres
  - Considering Fiction vs. Non-Fiction
  - Determining Your Reading Goals
3. Choosing the Right eBook Platform
  - Popular eBook Platforms
  - Features to Look for in an Grasshopper Model 227 Manual
  - User-Friendly Interface
4. Exploring eBook Recommendations from Grasshopper Model 227 Manual
  - Personalized Recommendations
  - Grasshopper Model 227 Manual User Reviews and Ratings
  - Grasshopper Model 227 Manual and Bestseller Lists
5. Accessing Grasshopper Model 227 Manual Free and Paid eBooks
  - Grasshopper Model 227 Manual Public Domain eBooks
  - Grasshopper Model 227 Manual eBook Subscription Services
  - Grasshopper Model 227 Manual Budget-Friendly Options
6. Navigating Grasshopper Model 227 Manual eBook Formats

- ePub, PDF, MOBI, and More
  - Grasshopper Model 227 Manual Compatibility with Devices
  - Grasshopper Model 227 Manual Enhanced eBook Features
7. Enhancing Your Reading Experience
    - Adjustable Fonts and Text Sizes of Grasshopper Model 227 Manual
    - Highlighting and Note-Taking Grasshopper Model 227 Manual
    - Interactive Elements Grasshopper Model 227 Manual
  8. Staying Engaged with Grasshopper Model 227 Manual
    - Joining Online Reading Communities
    - Participating in Virtual Book Clubs
    - Following Authors and Publishers Grasshopper Model 227 Manual
  9. Balancing eBooks and Physical Books Grasshopper Model 227 Manual
    - Benefits of a Digital Library
    - Creating a Diverse Reading Collection Grasshopper Model 227 Manual
  10. Overcoming Reading Challenges
    - Dealing with Digital Eye Strain
    - Minimizing Distractions
    - Managing Screen Time
  11. Cultivating a Reading Routine Grasshopper Model 227 Manual
    - Setting Reading Goals Grasshopper Model 227 Manual
    - Carving Out Dedicated Reading Time
  12. Sourcing Reliable Information of Grasshopper Model 227 Manual
    - Fact-Checking eBook Content of Grasshopper Model 227 Manual
    - Distinguishing Credible Sources
  13. Promoting Lifelong Learning
    - Utilizing eBooks for Skill Development
    - Exploring Educational eBooks
  14. Embracing eBook Trends
    - Integration of Multimedia Elements
    - Interactive and Gamified eBooks

## **Grasshopper Model 227 Manual Introduction**

In today's digital age, the availability of Grasshopper Model 227 Manual books and manuals for download has revolutionized the way we access information. Gone are the days of physically flipping through pages and carrying heavy textbooks or manuals. With just a few clicks, we can now access a wealth of knowledge from the comfort of our own homes or on the go. This article will explore the advantages of Grasshopper Model 227 Manual books and manuals for download, along with some popular platforms that offer these resources. One of the significant advantages of Grasshopper Model 227 Manual books and manuals for download is the cost-saving aspect. Traditional books and manuals can be costly, especially if you need to purchase several of them for educational or professional purposes. By accessing Grasshopper Model 227 Manual versions, you eliminate the need to spend money on physical copies. This not only saves you money but also reduces the environmental impact associated with book production and transportation. Furthermore, Grasshopper Model 227 Manual books and manuals for download are incredibly convenient. With just a computer or smartphone and an internet connection, you can access a vast library of resources on any subject imaginable. Whether you're a student looking for textbooks, a professional seeking industry-specific manuals, or someone interested in self-improvement, these digital resources provide an efficient and accessible means of acquiring knowledge. Moreover, PDF books and manuals offer a range of benefits compared to other digital formats. PDF files are designed to retain their formatting regardless of the device used to open them. This ensures that the content appears exactly as intended by the author, with no loss of formatting or missing graphics. Additionally, PDF files can be easily annotated, bookmarked, and searched for specific terms, making them highly practical for studying or referencing. When it comes to accessing Grasshopper Model 227 Manual books and manuals, several platforms offer an extensive collection of resources. One such platform is Project Gutenberg, a nonprofit organization that provides over 60,000 free eBooks. These books are primarily in the public domain, meaning they can be freely distributed and downloaded. Project Gutenberg offers a wide range of classic literature, making it an excellent resource for literature enthusiasts. Another popular platform for Grasshopper Model 227 Manual books and manuals is Open Library. Open Library is an initiative of the Internet Archive, a non-profit organization dedicated to digitizing cultural artifacts and making them accessible to the public. Open Library hosts millions of books, including both public domain works and contemporary titles. It also allows users to borrow digital copies of certain books for a limited period, similar to a library lending system. Additionally, many universities and educational institutions have their own digital libraries that provide free access to PDF books and manuals. These libraries often offer academic texts, research papers, and technical manuals, making them invaluable resources for students and researchers. Some notable examples include MIT OpenCourseWare, which offers free access to course materials from the Massachusetts Institute of Technology, and the Digital Public Library of America, which provides a vast collection of digitized books and historical documents. In conclusion, Grasshopper Model 227 Manual books and manuals for download

have transformed the way we access information. They provide a cost-effective and convenient means of acquiring knowledge, offering the ability to access a vast library of resources at our fingertips. With platforms like Project Gutenberg, Open Library, and various digital libraries offered by educational institutions, we have access to an ever-expanding collection of books and manuals. Whether for educational, professional, or personal purposes, these digital resources serve as valuable tools for continuous learning and self-improvement. So why not take advantage of the vast world of Grasshopper Model 227 Manual books and manuals for download and embark on your journey of knowledge?

### FAQs About Grasshopper Model 227 Manual Books

**What is a Grasshopper Model 227 Manual PDF?** A PDF (Portable Document Format) is a file format developed by Adobe that preserves the layout and formatting of a document, regardless of the software, hardware, or operating system used to view or print it. **How do I create a Grasshopper Model 227 Manual PDF?** There are several ways to create a PDF: Use software like Adobe Acrobat, Microsoft Word, or Google Docs, which often have built-in PDF creation tools. **Print to PDF:** Many applications and operating systems have a "Print to PDF" option that allows you to save a document as a PDF file instead of printing it on paper. **Online converters:** There are various online tools that can convert different file types to PDF. **How do I edit a Grasshopper Model 227 Manual PDF?** Editing a PDF can be done with software like Adobe Acrobat, which allows direct editing of text, images, and other elements within the PDF. Some free tools, like PDFescape or Smallpdf, also offer basic editing capabilities. **How do I convert a Grasshopper Model 227 Manual PDF to another file format?** There are multiple ways to convert a PDF to another format: Use online converters like Smallpdf, Zamzar, or Adobe Acrobat's export feature to convert PDFs to formats like Word, Excel, JPEG, etc. Software like Adobe Acrobat, Microsoft Word, or other PDF editors may have options to export or save PDFs in different formats. **How do I password-protect a Grasshopper Model 227 Manual PDF?** Most PDF editing software allows you to add password protection. In Adobe Acrobat, for instance, you can go to "File" -> "Properties" -> "Security" to set a password to restrict access or editing capabilities. **Are there any free alternatives to Adobe Acrobat for working with PDFs?** Yes, there are many free alternatives for working with PDFs, such as: LibreOffice: Offers PDF editing features. PDFsam: Allows splitting, merging, and editing PDFs. Foxit Reader: Provides basic PDF viewing and editing capabilities. **How do I compress a PDF file?** You can use online tools like Smallpdf, ILovePDF, or desktop software like Adobe Acrobat to compress PDF files without significant quality loss. Compression reduces the file size, making it easier to share and download. **Can I fill out forms in a PDF file?** Yes, most PDF viewers/editors like Adobe Acrobat, Preview (on Mac), or various online tools allow you to fill out forms in PDF files by selecting text fields and entering information. **Are there any restrictions when working with PDFs?** Some PDFs might have restrictions set by their creator,



such as password protection, editing restrictions, or print restrictions. Breaking these restrictions might require specific software or tools, which may or may not be legal depending on the circumstances and local laws.

**Find Grasshopper Model 227 Manual :**

*heart of the message of medjugorje*

*health care reform in radiology*

**haynes repair manual sentra**

*haynes repair manual vauxhall astra van*

**head first c jennifer greene**

*head of the family christian fatherhood in the modern world*

~~health promotion & education research methods using the five chapter thesis dissertation model~~

heal yourself by clearing the chakras

head for success business study guide

haynes repair manual vz

**health of women with intellectual disabilities**

*haynes vauxhall vectra service and repair manual*

headway beginner third edition workbook answer key

*he is more than just a god*

health effects of toxic substances

**Grasshopper Model 227 Manual :**

*the memory jogger ii a pocket guide of tools for continuous* - Aug 12 2022

the memory jogger ii now includes the seven quality control tools the seven management and planning tools and a problem solving case study example which are presented in a format that we hope will allow you to find relevant information so easily you ll always find space for it in your pocket or pocketbook 1994 by goal qpc any

**the memory jogger 2 tools for continuous improvement and effective** - Dec 16 2022

jun 1 2018 the memory jogger 2 second edition contains all the tools found in the first edition of the memory jogger ii plus 50 pages of new charts and detailed diagram samples a new tool and a case study

**six sigma memory jogger ii a pocket guide amazon com** - Mar 19 2023

may 18 2017 six sigma memory jogger ii a pocket guide spiral bound may 18 2017 by michael brassard author lynda finn author dana ginn author 4 5 103 ratings see all formats and editions the six sigma memory jogger ii is the indispensable training and performance support resource for six sigma project team members

[the memory jogger 2 tools for continuous improvement and](#) - Jul 23 2023

the memory jogger 2 tools for continuous improvement and effective planning brassard michael amazon com tr kitap

**memory jogger 2 tools for continuous improvement effective** - Aug 24 2023

the memory jogger 2 second edition contains all the tools found in the first edition of the memory jogger ii plus 50 pages of new charts and detailed diagram samples a new tool and a case study tools include activity network diagram affinity diagram brainstorming brainwriting cause effect fishbone check sheets control charts

*memory jogger ii healthcare edition a pocket guide of tools for* - Feb 18 2023

memory jogger ii healthcare edition a pocket guide of tools for continuous improvement and effective planning brassard michael amazon com tr

*the memory jogger 2 healthcare edition a pocket guide of* - Sep 13 2022

oct 1 2020 the memory jogger 2 healthcare edition a pocket guide of tools for continuous improvement and effective planning spiral bound october 1 2020 by michael brassard author diane ritter author goal qpc editor michele kierstead janet maccausland michele kierstead janet maccausland illustrator 1 more

*the memory jogger ii google books* - Mar 07 2022

the memory jogger ii a pocket guide of tools for continuous improvement effective planning michael brassard diane ritter goal qpc 1994 innovations 164 pages 0 reviews reviews aren t

[the memory jogger 2 a desktop guide of tools for continuous](#) - May 21 2023

the memory jogger 2 a desktop guide of tools for continuous improvement and effective planning spiral brassard michael amazon com tr kitap

**the memory jogger 2 second edition asq** - Jun 22 2023

the memory jogger 2 second edition contains all the tools found in the first edition of the memory jogger 2 plus 50 pages of new charts and detailed diagram samples a new tool and a case study book

**goal qpc home of the quality driven memory joggers** - Feb 06 2022

six sigma memory jogger ii 2018 version rated 4 75 out of 5 21 95 28 95 select options the yellow belt memory jogger 2nd edition rated 5 00 out of 5 19 95 25 95 select options lean six sigma tools memory jogger rated 5 00 out of 5 23 95 29 95 select options the complete lean six sigma handbook sigma magic software

**the memory jogger 2 tools for continuous turkey ubuy** - Apr 20 2023

shop the memory jogger 2 tools for continuous improvement and effective planning spiral bound june 1 2016 online at a best price in turkey get special offers deals discounts fast delivery options on international shipping with every purchase on ubuy turkey 1576811131

**the memory jogger 2 tools for continuous improvement and effective** - Sep 25 2023

jun 1 2018 the memory jogger 2 tools for continuous improvement and effective planning goal qpc michael brassard diane ritter goal qpc Janet Maccausland Janet Maccausland on amazon com free shipping on qualifying offers the memory jogger 2 tools for continuous improvement and effective planning

*memory jogger 2 second edition 2018 revision goal qpc* - Jul 11 2022

dramatically improve your productivity quality and planning with the 2018 revision of this highly successful pocket guide of basic and advanced quality tools a problem solving model and improvement team guidelines

**the memory jogger ii a pocket guide of tools for continuous** - Apr 08 2022

jul 5 2019 the memory jogger ii a pocket guide of tools for continuous improvement effective planning by brassard michael ritter diane open library not in library

the memory jogger ii a pocket guide of tools for continuous - Oct 14 2022

the memory jogger ii is an easy to use pocket guide that describes tools to help you make continuous improvements in an organization the tools help people at all levels participate in identifying and solving problems eliminating rework streamlining processes improving cross functional communication decreasing costs and measuring results

**the memory jogger ii a pocket guide of tools for continuous** - Nov 15 2022

jan 15 1994 the memory jogger ii is an easy to use pocket guide that describes tools to help you make continuous improvements in an organization the tools help people at all levels participate in identifying and solving problems eliminating rework streamlining processes improving cross functional communication decreasing costs and measuring results

**goal opc memory jogger ii türkiye yursat** - May 09 2022

goal opc markası memory jogger ii türkiye içi teslim ve satışı için bizimle iletişime geçin yursat orijinal ve yeni ürün tedarik etmektedir distribütör değildir info yursat com tr

*memory jogger ii emated* - Jun 10 2022

memory jogger ii kodlu ürün ve bu ürün haricinde tüm ürünlerin tedarigi için bizimle iletişim kurabilirsiniz türkiye deki yağın lojistik ağımız ile ürünlerinize en uygun şekilde adresinize teslim edilmek koşuluyla hizmetlerimizden yararlanın

**the memory jogger 2 google books** - Jan 17 2023

goal qpc 2010 continuous improvement process 214 pages the memory jogger ii is newly updated to include many more examples by companies practicing the tools today as well as an in depth case study from an on line retailer

[crazy a father s search through america s mental](#) - Nov 06 2022

web apr 20 2006 in this book crazy a father s search through america s mental health madness pete earley writes about different prisons than roth but the basic story is

*crazy a father s search through america s mental health* - Nov 25 2021

web apr 3 2007 crazy a father s search through america s mental health madness kindle edition by earley pete download it once and read it on your kindle device pc

[crazy a father s search through america s mental health](#) - Feb 09 2023

web about this ebook arrow forward a magnificent gift to those of us who love someone who has a mental illness earley has used his considerable skills to meticulously research

**crazy a father s search through america s mental health** - Mar 30 2022

web a short presentation on the problems with america s mental health care system highlighted in pete earley s book crazy a father s search through america s m

[crazy a father s search through america s mental](#) - Jun 13 2023

web summary and study guide crazy a father s search through america s mental health madness published in 2006 is a blend of memoir and journalism by the author and

*crazy a father s search through america s mental health madness* - Dec 27 2021

web in the book crazy a father s search through america s mental health madness pete earley tells a story that is all too familiar to nami members as an award winning

[crazy a father s search through america s mental health](#) - Mar 10 2023

web may 31 2007 crazy a father s search through america s mental health madness by investigative journalist and award winning author pete earley is the story of the

*crazy summary and study guide supersummary* - May 12 2023

web apr 3 2007 crazy a father s search through america s mental health madness pete earley penguin apr 3 2007 psychology 384 pages a magnificent gift to those of us

**crazy a father s search through america s mental health** - Sep 23 2021

*crazy a father s search through america s mental* - Aug 15 2023

web suddenly the two of us were thrown headlong into the maze of contradictions disparities and catch 22s that make up america s mental health system crazy a father s

**crazy a father s search through america s mental health** - Oct 05 2022

web crazy a father s search through america s mental health madness earley pete amazon com tr kitap

**crazy a father s search through america s mental** - Jan 08 2023

web he had no idea what it was like to be on the inside looking out until his son mike was declared mentally ill and earley was thrown headlong into the maze of contradictions

*editions of crazy a father s search through america s mental* - Feb 26 2022

web at once a classic account of the ravages of mental illness and a major american autobiography a mind that found itself tells the story of a young man who is gradually

**crazy a father s search through america s mental health** - Apr 11 2023

web jun 7 2007 crazy a father s search through america journal of legal medicine volume 28 2007 issue 2 176 views 0 crossref citations to date 0 altmetric book

**crazy a father s search through america s mental health** - Jun 01 2022

web stigma is a serious issue and a legitimate concern mental illness no doubt carries with it a social stigma of considerable import in our society earley 2006 nmha 1986

*crazy a father s search through america s mental health* - Sep 04 2022

web crazy a father s search through america s mental health madness author pete earley summary the author shares his frustrating experiences trying to get help for his son

*crazy a father s search through america s mental health* - Dec 07 2022

web topics earley mike earley pete mentally ill offenders florida miami case studies mentally ill family relationships case studies mentally ill persons biography

[crazy a father s search through america s mental health](#) - Jul 02 2022

web this crazy a father s search through america s mental health madness having great arrangement in word and layout so you will not really feel uninterested in reading see

[crazy a father s search through america s mental health system](#) - Jan 28 2022

web apr 3 2007 buy crazy a father s search through america s mental health madness paperback book by pete earley from as low as 18 free shipping on all orders over

**crazy a father s search through america s mental health** - Aug 03 2022

web crazy a father s search through america s mental health madness pete earley putnam 25 95 372pp isbn 978 0 399 15313 6

**crazy a father s search through america academia edu** - Apr 30 2022

web editions for crazy a father s search through america s mental health madness 0425213897 paperback published in 2007

published in 2007 kindle ed

*crazy a father s search through america s mental* - Jul 14 2023

web mar 1 2021 *crazy a father s search through america s mental health madness pete earley on amazon com free shipping on qualifying offers crazy a father s*

*crazy a father s search through book by pete earley* - Oct 25 2021

**parcoursup le guide ultime 2020 partez gagnant leslibraires fr** - Apr 08 2023

web oct 23 2019 *parcoursup avec le guide ultime 2020 partez gagnant comprendre le fonctionnement de parcoursup et déjouer ses pièges compléter ses voeux rédiger ses*

*parcoursup le guide ultime 2020 partez gagnant fr 2023* - Mar 07 2023

web parcoursup le guide ultime 2020 partez gagnant fr parcoursup le guide ultime jun 06 2023 extrait de la 4e de couv parcoursup avec le guide ultime 2020 partez gagnant comprendre le fonctionnement de parcoursup et déjouer ses pièges compléter ses voeux rédiger ses projets de formation motivés

*parcoursup le guide ultime 2020 partez gagnant hachette fr* - Sep 13 2023

web may 2 2022 *parcoursup avec le guide ultime 2020 partez gagnant comprendre le fonctionnement de parcoursup et déjouer ses pièges compléter ses voeux rédiger ses*

*downloadable free pdfs parcoursup le guide ultime 2020 partez gagnant fr* - Oct 02 2022

web the guardian university guide 2011 simon and schuster the vast circulations of mobile devices sensors and data mean that the social world is now defined by a complex

*parcoursup le guide ultime 2020 partez gagnant fr* - Jul 11 2023

web parcoursup avec le guide ultime 2020 partez gagnant comprendre le fonctionnement de parcoursup et déjouer ses pièges saisir ses voeux compléter son profil et rédiger

**parcoursup accueil** - Jan 25 2022

web parcoursup le guide ultime 2020 partez gagnant fr 3 3 shale a geological formation that contains the fossils of many strange prehistoric life forms the burgess shale is not entirely about writing itself however atwood also provides some insight into the meager writing infrastructure of that time taking a lighthearted look at the early days

*parcoursup le guide ultime 2020 partez gagnant picclick fr* - Jun 10 2023

web parcoursup le guide ultime 2020 partez gagnant franchi livre état bon eur 5 70 À vendre produits d occasion testés certified second hand articles plus

**parcoursup le guide ultime 2020 partez gagnant fr** - Nov 22 2021

**parcoursup le guide ultime 2020 partez gagnant fr full pdf** - May 29 2022

web nov 24 2021 si parcoursup constitue l'étape incontournable de votre année de terminale la plateforme vous laissera le temps de vous préparer et de réfléchir à votre orientation

**parcoursup le guide ultime 2020 partez gagnant fr** - Jun 29 2022

web parcoursup le guide ultime 2020 partez gagnant fr downloaded from checkin thecontemporaryaustin org by guest joshua paloma the plus houghton

parcoursup le guide ultime 2020 partez gagnant amazon fr - Oct 14 2023

web 6 60 8 d occasion à partir de 3 61 parcoursup avec le guide ultime 2020 partez gagnant comprendre le fonctionnement de parcoursup et déjouer ses pièges

parcoursup le guide ultime 2020 partez gagnant fr pdf - Dec 24 2021

web parcoursup le guide ultime 2020 partez gagnant fr parcoursup le guide ultime 2020 partez gagnant fr 4 downloaded from pivotid uvu edu on 2019 04 10 by guest plays in

parcoursup le guide ultime 2020 partez gagnant fr - Jul 31 2022

web oct 22 2023 parcoursup le guide ultime 2020 marie pierre petit 2019 10 23 parcoursup avec le guide ultime 2020 partez gagnant comprendre le

parcoursup le guide ultime 2020 partez gagnant abebooks - Dec 04 2022

web parcoursup le guide ultime 2020 partez gagnant franchissez les étapes réalisez vos rêves de petit marie pierre renaud yveline et d'autres livres articles d'art et de

*parcoursup le guide ultime 2020 partez gagnant franchissez* - Jan 05 2023

web auteur petit marie pierre isbn 9782100801787 Édition dunod livraison gratuite expédiée en 24h satisfait ou remboursé

**parcoursup le guide ultime 2020 partez gagnant fr 2022** - Feb 23 2022

web retrouvez les informations utiles pour élaborer votre projet d'orientation lycee avenir onisep fr des infos et des conseils pour construire son projet d'orientation le

**parcoursup le guide ultime partez gagnant franchissez les** - Aug 12 2023

web parcoursup le guide ultime partez gagnant franchissez les étapes réalisez vos rêves édition 2020 par marie pierre petit yveline renaud aux éditions dunod parcoursup

**phase d'information de parcoursup l'étudiant** - Apr 27 2022

web jun 24 2021 à partir de 2022 le point d'étape n'est plus obligatoire sur parcoursup cette année le point d'étape se déroulera entre le 29 juin et le 1er juillet 2021 une étape

parcoursup le guide ultime 2020 partez gagnant fr pdf - Sep 01 2022

web 2 parcoursup le guide ultime 2020 partez gagnant fr 2022 07 10 l art poétique springer science business media new york times bestseller greg gutfeld

**parcoursup le point d étape est il obligatoire pour tous les** - Mar 27 2022

web parcoursup le guide ultime 2020 partez gagnant fr 3 3 training and family and gender policy the book will therefore be invaluable to students and researchers of global social

parcoursup le guide ultime 2020 partez gagnant picclick fr - May 09 2023

web parcoursup le guide ultime 2020 partez gagnant franchi livre état bon eur 6 06 À vendre il n y a pas d affichage de la tva d occasion bon second

**parcoursup le guide ultime 2020 partez gagnant eurolivre fr** - Feb 06 2023

web parcoursup le guide ultime 2020 partez gagnant franchissez les étapes réalisez vos rêves trouvez tous les livres de sur eurolivre fr vous pouvez commander des

*guide de l étudiant parcoursup 2022 2023 l étudiant* - Nov 03 2022

web parcoursup le guide ultime 2020 partez gagnant fr collected essays in architectural criticism jan 05 2023 collected essays in architectural criticism is an indispensable anthology of writing by one of the most important voices in architectural theory of the last 50 years born in 1921 colquhoun graduated from the architectural association in