

[G21HD]

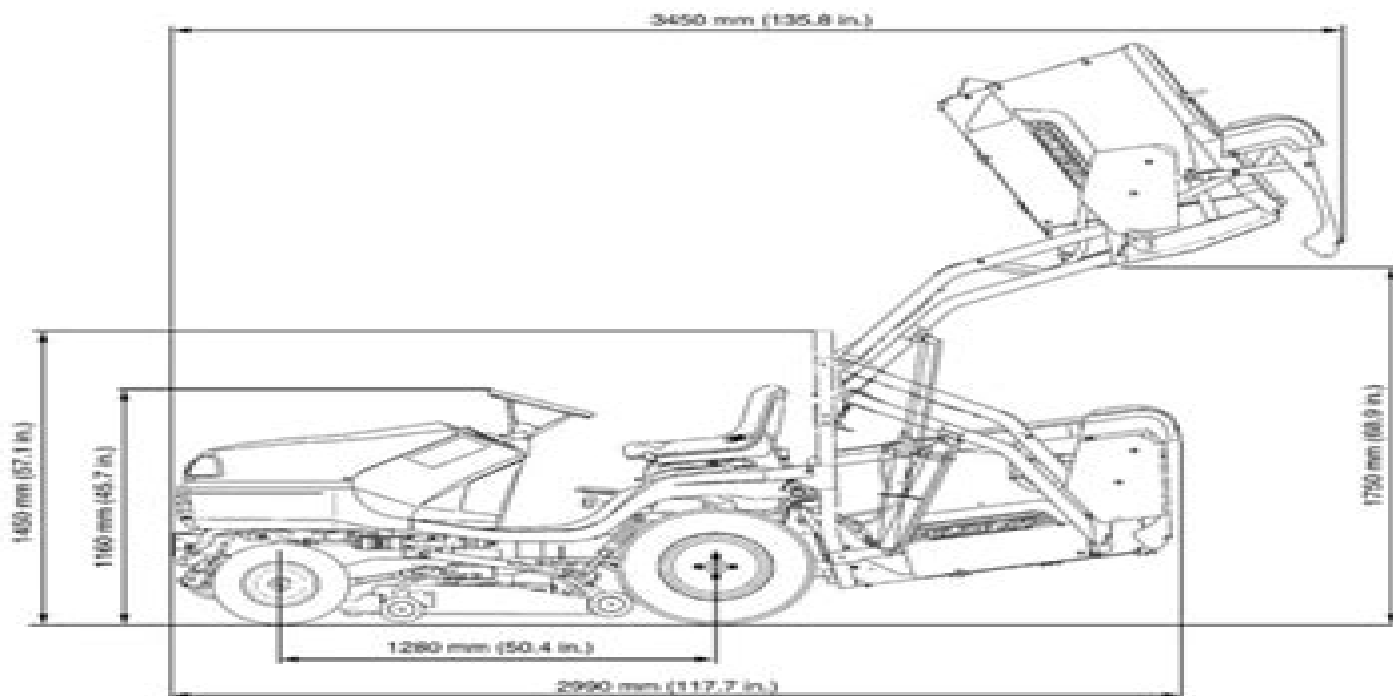
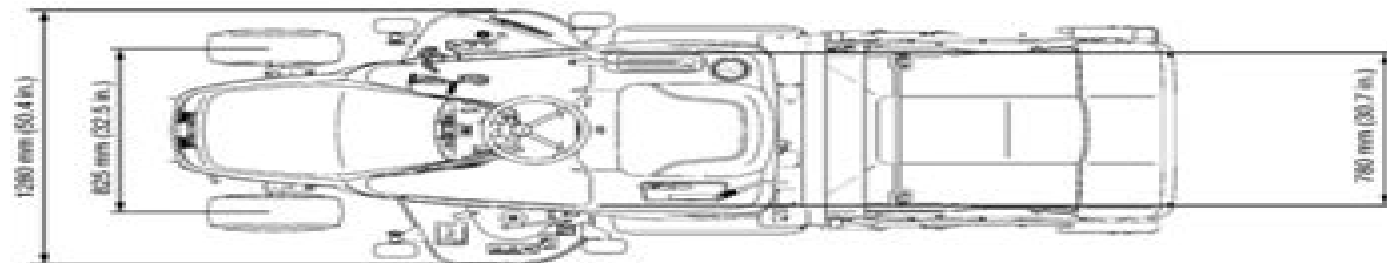

3G0AAAADFP001B

Kubota G21 Series Repair Manuals

M Woodhall



Kubota G21 Series Repair Manuals:

This book delves into Kubota G21 Series Repair Manuals. Kubota G21 Series Repair Manuals is a vital topic that must be grasped by everyone, ranging from students and scholars to the general public. This book will furnish comprehensive and in-depth insights into Kubota G21 Series Repair Manuals, encompassing both the fundamentals and more intricate discussions.

1. The book is structured into several chapters, namely:

- Chapter 1: Introduction to Kubota G21 Series Repair Manuals
- Chapter 2: Essential Elements of Kubota G21 Series Repair Manuals
- Chapter 3: Kubota G21 Series Repair Manuals in Everyday Life
- Chapter 4: Kubota G21 Series Repair Manuals in Specific Contexts
- Chapter 5: Conclusion

2. In chapter 1, the author will provide an overview of Kubota G21 Series Repair Manuals. The first chapter will explore what Kubota G21 Series Repair Manuals is, why Kubota G21 Series Repair Manuals is vital, and how to effectively learn about Kubota G21 Series Repair Manuals.
3. In chapter 2, the author will delve into the foundational concepts of Kubota G21 Series Repair Manuals. This chapter will elucidate the essential principles that need to be understood to grasp Kubota G21 Series Repair Manuals in its entirety.
4. In chapter 3, the author will examine the practical applications of Kubota G21 Series Repair Manuals in daily life. This chapter will showcase real-world examples of how Kubota G21 Series Repair Manuals can be effectively utilized in everyday scenarios.
5. In chapter 4, this book will scrutinize the relevance of Kubota G21 Series Repair Manuals in specific contexts. The fourth chapter will explore how Kubota G21 Series Repair Manuals is applied in specialized fields, such as education, business, and technology.
6. In chapter 5, the author will draw a conclusion about Kubota G21 Series Repair Manuals. The final chapter will summarize the key points that have been discussed throughout the book.

The book is crafted in an easy-to-understand language and is complemented by engaging illustrations. It is highly recommended for anyone seeking to gain a comprehensive understanding of Kubota G21 Series Repair Manuals.

http://www.armchairempire.com/results/scholarship/fetch.php/Italia_1986_Michelin.pdf

Table of Contents Kubota G21 Series Repair Manuals

1. Understanding the eBook Kubota G21 Series Repair Manuals
 - The Rise of Digital Reading Kubota G21 Series Repair Manuals
 - Advantages of eBooks Over Traditional Books
2. Identifying Kubota G21 Series Repair Manuals
 - Exploring Different Genres
 - Considering Fiction vs. Non-Fiction
 - Determining Your Reading Goals
3. Choosing the Right eBook Platform
 - Popular eBook Platforms
 - Features to Look for in an eBook Platform
 - User-Friendly Interface
4. Exploring eBook Recommendations from Kubota G21 Series Repair Manuals
 - Personalized Recommendations
 - Kubota G21 Series Repair Manuals User Reviews and Ratings
 - Kubota G21 Series Repair Manuals and Bestseller Lists
5. Accessing Kubota G21 Series Repair Manuals Free and Paid eBooks
 - Kubota G21 Series Repair Manuals Public Domain eBooks
 - Kubota G21 Series Repair Manuals eBook Subscription Services
 - Kubota G21 Series Repair Manuals Budget-Friendly Options
6. Navigating Kubota G21 Series Repair Manuals eBook Formats
 - ePub, PDF, MOBI, and More
 - Kubota G21 Series Repair Manuals Compatibility with Devices
 - Kubota G21 Series Repair Manuals Enhanced eBook Features
7. Enhancing Your Reading Experience
 - Adjustable Fonts and Text Sizes of Kubota G21 Series Repair Manuals
 - Highlighting and Note-Taking Kubota G21 Series Repair Manuals
 - Interactive Elements Kubota G21 Series Repair Manuals
8. Staying Engaged with Kubota G21 Series Repair Manuals

- Joining Online Reading Communities
 - Participating in Virtual Book Clubs
 - Following Authors and Publishers Kubota G21 Series Repair Manuals
9. Balancing eBooks and Physical Books Kubota G21 Series Repair Manuals
- Benefits of a Digital Library
 - Creating a Diverse Reading Collection Kubota G21 Series Repair Manuals
10. Overcoming Reading Challenges
- Dealing with Digital Eye Strain
 - Minimizing Distractions
 - Managing Screen Time
11. Cultivating a Reading Routine Kubota G21 Series Repair Manuals
- Setting Reading Goals Kubota G21 Series Repair Manuals
 - Carving Out Dedicated Reading Time
12. Sourcing Reliable Information of Kubota G21 Series Repair Manuals
- Fact-Checking eBook Content of Kubota G21 Series Repair Manuals
 - Distinguishing Credible Sources
13. Promoting Lifelong Learning
- Utilizing eBooks for Skill Development
 - Exploring Educational eBooks
14. Embracing eBook Trends
- Integration of Multimedia Elements
 - Interactive and Gamified eBooks

Kubota G21 Series Repair Manuals Introduction

Kubota G21 Series Repair Manuals Offers over 60,000 free eBooks, including many classics that are in the public domain. Open Library: Provides access to over 1 million free eBooks, including classic literature and contemporary works. Kubota G21 Series Repair Manuals Offers a vast collection of books, some of which are available for free as PDF downloads, particularly older books in the public domain. Kubota G21 Series Repair Manuals : This website hosts a vast collection of scientific articles, books, and textbooks. While it operates in a legal gray area due to copyright issues, its a popular resource for finding various publications. Internet Archive for Kubota G21 Series Repair Manuals : Has an extensive collection of

digital content, including books, articles, videos, and more. It has a massive library of free downloadable books. Free-eBooks Kubota G21 Series Repair Manuals Offers a diverse range of free eBooks across various genres. Kubota G21 Series Repair Manuals Focuses mainly on educational books, textbooks, and business books. It offers free PDF downloads for educational purposes. Kubota G21 Series Repair Manuals Provides a large selection of free eBooks in different genres, which are available for download in various formats, including PDF. Finding specific Kubota G21 Series Repair Manuals, especially related to Kubota G21 Series Repair Manuals, might be challenging as they're often artistic creations rather than practical blueprints. However, you can explore the following steps to search for or create your own Online Searches: Look for websites, forums, or blogs dedicated to Kubota G21 Series Repair Manuals, Sometimes enthusiasts share their designs or concepts in PDF format. Books and Magazines Some Kubota G21 Series Repair Manuals books or magazines might include. Look for these in online stores or libraries. Remember that while Kubota G21 Series Repair Manuals, sharing copyrighted material without permission is not legal. Always ensure you're either creating your own or obtaining them from legitimate sources that allow sharing and downloading. Library Check if your local library offers eBook lending services. Many libraries have digital catalogs where you can borrow Kubota G21 Series Repair Manuals eBooks for free, including popular titles. Online Retailers: Websites like Amazon, Google Books, or Apple Books often sell eBooks. Sometimes, authors or publishers offer promotions or free periods for certain books. Authors Website Occasionally, authors provide excerpts or short stories for free on their websites. While this might not be the Kubota G21 Series Repair Manuals full book, it can give you a taste of the authors writing style. Subscription Services Platforms like Kindle Unlimited or Scribd offer subscription-based access to a wide range of Kubota G21 Series Repair Manuals eBooks, including some popular titles.

FAQs About Kubota G21 Series Repair Manuals Books

1. Where can I buy Kubota G21 Series Repair Manuals books? Bookstores: Physical bookstores like Barnes & Noble, Waterstones, and independent local stores. Online Retailers: Amazon, Book Depository, and various online bookstores offer a wide range of books in physical and digital formats.
2. What are the different book formats available? Hardcover: Sturdy and durable, usually more expensive. Paperback: Cheaper, lighter, and more portable than hardcovers. E-books: Digital books available for e-readers like Kindle or software like Apple Books, Kindle, and Google Play Books.
3. How do I choose a Kubota G21 Series Repair Manuals book to read? Genres: Consider the genre you enjoy (fiction, non-fiction, mystery, sci-fi, etc.). Recommendations: Ask friends, join book clubs, or explore online reviews and

- recommendations. Author: If you like a particular author, you might enjoy more of their work.
4. How do I take care of Kubota G21 Series Repair Manuals books? Storage: Keep them away from direct sunlight and in a dry environment. Handling: Avoid folding pages, use bookmarks, and handle them with clean hands. Cleaning: Gently dust the covers and pages occasionally.
 5. Can I borrow books without buying them? Public Libraries: Local libraries offer a wide range of books for borrowing. Book Swaps: Community book exchanges or online platforms where people exchange books.
 6. How can I track my reading progress or manage my book collection? Book Tracking Apps: Goodreads, LibraryThing, and Book Catalogue are popular apps for tracking your reading progress and managing book collections. Spreadsheets: You can create your own spreadsheet to track books read, ratings, and other details.
 7. What are Kubota G21 Series Repair Manuals audiobooks, and where can I find them? Audiobooks: Audio recordings of books, perfect for listening while commuting or multitasking. Platforms: Audible, LibriVox, and Google Play Books offer a wide selection of audiobooks.
 8. How do I support authors or the book industry? Buy Books: Purchase books from authors or independent bookstores. Reviews: Leave reviews on platforms like Goodreads or Amazon. Promotion: Share your favorite books on social media or recommend them to friends.
 9. Are there book clubs or reading communities I can join? Local Clubs: Check for local book clubs in libraries or community centers. Online Communities: Platforms like Goodreads have virtual book clubs and discussion groups.
 10. Can I read Kubota G21 Series Repair Manuals books for free? Public Domain Books: Many classic books are available for free as they're in the public domain. Free E-books: Some websites offer free e-books legally, like Project Gutenberg or Open Library.

Find Kubota G21 Series Repair Manuals :

[italia 1986 michelin](#)

[jabra bt125 manual](#)

[iviie sicle les grands auteurs franais du programme](#)

[jacuzzi laser 160 manual](#)

iwork 09 the missing manual the missing manual missing manuals

it libertynsk gehucht gedichten

jaguar mk vii xk120 series service repair workshop manual

[j s bach the complete cantatas](#)

[iveco c78 ens m20 10 engine full service repair manual 2007 2013](#)

[its a magical world a calvin and hobbes collection](#)

izinkondlo zesizulu zothando

[italien 2016 kalender](#)

[j ngling fjodor michailowitsch dostojewski ebook](#)

its a waverly life the misadventures of waverly bryson

[itil v3 books download](#)

Kubota G21 Series Repair Manuals :

lionel jadot an autobiography by wim pauwels 2010 - Jun 17 2022

web find many great new used options and get the best deals for lionel jadot an autobiography by wim pauwels 2010

hardcover at the best online prices at ebay free shipping for many products

[9789089440587 lionel jadot an autobiography pauwels wim](#) - Feb 23 2023

web abebooks com lionel jadot an autobiography 9789089440587 by pauwels wim and a great selection of similar new used and collectible books available now at great prices 9789089440587 lionel jadot an autobiography pauwels wim 9089440585

[lionel jadot an autobiography by pauwels wim amazon ae](#) - Sep 20 2022

web buy lionel jadot an autobiography by pauwels wim online on amazon ae at best prices fast and free shipping free returns cash on delivery available on eligible purchase

lionel jadot an autobiography ouvrages sur l habitat wim - Oct 02 2023

web lionel jadot an autobiography ouvrages sur l habitat wim pauwels amazon com tr kitap

lionel jadot an autobiography worldcat org - Sep 01 2023

web summary lionel jadot b 1960 is a scion of the highly reputed family of furniture makers vanhamme who have excelled in craftsmanship skills since 1895 the vanhamme workshops were the young lionel jadot s favourite play area and very early after his classical art education he achieved his first two complete projects two lofts and a

lionel jadot an autobiography ouvrage multilingue - Jan 25 2023

web résumé voir tout lionel jadot 1969 fait partie de la célèbre famille des ébénistes vanhamme qui depuis 1895 excellent dans le savoir faire artisanal enfant lionel jadot avait fait des ateliers vanhamme son terrain de jeu de prédilection

[lionel jadot an autobiography 2010 edition open library](#) - Jun 29 2023

web lionel jadot an autobiography by wim pauwels 0 ratings 0 want to read 0 currently reading 0 have read

lionel jadot an autobiography wim pauwels cultura - Apr 15 2022

web lionel jadot an autobiography par wim pauwels aux éditions beta plus

[lionel jadot an autobiography hardcover barnes noble](#) - Oct 22 2022

web sep 16 2010 the workshops of the highly reputed furniture makers vanhamme were the young lionel jadot s favorite play area and very early after his classical art

[lionel jadot an autobiography programma syriza gr](#) - Feb 11 2022

web lionel jadot an autobiography downloaded from programma syriza gr by guest jacoby kane travel home black dog pub limited manuscript is a reference book sui generis a combination of inspiration guide and notebook it explores basic aspects of interior design ceilings floors walls doors stairs and the

lionel jadot an autobiography by wim pauwels goodreads - May 29 2023

web 256 pages hardcover first published october 16 2010 book details editions

[lionel jadot an autobiography by pok marie near fine](#) - Nov 22 2022

web may 6 1998 abebooks com lionel jadot an autobiography folio blind stamped cloth dustwrapper 256pp illustrated throughout first edition french text with english and dutch translations

lionel jadot an autobiography de jean luc laloux decitre - Mar 15 2022

web aug 19 2010 marie pok jean claude jadot préfacier note moyenne donner le premier avis lionel jadot 1969 fait partie de la célèbre famille des ébénistes vanhamme qui depuis 1895 excellent dans le savoir faire artisanal enfant lionel lire la suite 90 70 neuf expédié sous 6 à 12 jours livré chez vous entre le 25 octobre et le 31 octobre

[lionel jadot an autobiography amazon com](#) - Jul 31 2023

web oct 16 2010 lionel jadot 1969 fait partie de la célèbre famille des ébénistes vanhamme qui depuis 1895 excellent dans le savoir faire artisanal enfant lionel jadot avait fait des ateliers vanhamme son terrain de jeu de prédilection

lionel jadot an autobiography pauwels wim amazon es libros - May 17 2022

web selecciona el departamento que quieras buscar

[lionel jadot an autobiography pauwels wim amazon fr livres](#) - Apr 27 2023

web lionel jadot 1969 fait partie de la célèbre famille des ébénistes vanhamme qui depuis 1895 excellent dans le savoir faire artisanal enfant lionel jadot avait fait des ateliers vanhamme son terrain de jeu de prédilection très tôt déjà après ses humanités artistiques on lui confie ses premiers projets d aménagement global

[lionel jadot an autobiography hardcover 1 july 2010](#) - Mar 27 2023

web jul 1 2010 select the department you want to search in

[lionel jadot an autobiography pauwels wim amazon de](#) - Jul 19 2022

web wähle die kategorie aus in der du suchen möchtest

[lionel jadot an autobiography william stout architectural books](#) - Aug 20 2022

web lionel jadot an autobiography cl beta plus 2010 book id 84576 exuberantly baroque sometimes minimal always inspired and sophisticated interiors 216 pp 130 color illus jadot

[lionel jadot autobiography abebooks](#) - Dec 24 2022

web lionel jadot an autobiography by pauwels wim and a great selection of related books art and collectibles available now at abebooks co uk

[blue pelican java answers tests keys studyres](#) - Oct 06 2023

web answers 21 3 key to exercise on lesson 21 1 the classes that convert primitives to objects are called wrapper classes 2 name the four primitive data types with which wrapper classes primarily deal int double boolean char 3 write code that will convert double dx into a wrapper class object

[lesson 16 gas mileage multiple classes project](#) - May 21 2022

web oct 13 2011 i m working on a project from the blue pelican java book lesson 16 project gas mileage it asks to create two classes one is automobile which holds the methods i will work with the other class tester is the main class every time i run the tester class it returns a value of infinity

lesson 1 12 blue pelican java - Dec 28 2022

web lesson 10 the switch statement and char building a menu 4 05 switch skeleton 5 18 entering code into a switch statement 4 58 using char in a switch statement 4 23 using same code for multiple cases 3 33 lesson 11 the for loop a simple for loop 8 25

[blue pelican java](#) - Jun 02 2023

web answers 39 2 key to quiz on lesson 39 1 what is the value of 5 five factorial 120 2 what is returned by method 8 public static int method int n blue pelican java answers tests keys author charles e cook subject computer science i

blue pelican java - Jan 29 2023

web start on lesson 1 proceed at a reasonable rate see appendix p for a time line don t skip anything except for perhaps lesson 47 and lesson 53 give a simple confidence building quiz on each lesson quizzes and keys are provided in the answer book available at bluepelicanjava com

[github let s build from here github](#) - Apr 19 2022

web payload allshortcutsenabled false filetree lesson 3 string operations items name cases java path lesson 3 string operations cases java

[blue pelican java answers tests keys compress pdf answers](#) - Oct 26 2022

web answers 16 2 g3 g46g72g92g3g87g82g3g52g88g76g93g3g73g82g85g3g47g72g86g86g82g81g3g20g25g3 use the class below to answer the questions public class tvshow public tvshow string showname int numminutes public double cost int i other methods and

blue pelican java answer key pdf register free to - Mar 31 2023

web blue pelican java answer key pdf register free to download files file name blue pelican java answer key pdf blue pelican java answer key download cs313 course hero

blue pelican java lesson 20 exercise answers online degrees - Feb 15 2022

web 12 jan 2021 on this content blue pelican java answers tests keys blue pelican java lesson 20 exercise answers is important information accompanied by photo and hd pictures sourced from all websites in the world download this image for free in high definition resolution the choice download button below

github joshua ciffer blue pelican blue pelican java textbook - Jul 03 2023

web joshua ciffer blue pelican public master 1 branch 0 tags code 34 commits failed to load latest commit information lesson 0 my first project lesson 1 printing lesson 10 switch statements char

lesson 19 project two orders for price of one sorting arrays - Jul 23 2022

web dec 12 2011 i am using the blue pelican java textbook and am stuck on the project for lesson 19 it asks to modify the code below to print two side by side columns the first column should be in ascending order like the code below will print and the second column should be in descending order

blue pelican java 18 25 excluding 21 22 flashcards quizlet - Aug 24 2022

web what are the three ways to declare and initialize an array int a new int 400 a 0 97 a 1 62 a 2 85 int a 97 62 85 int a new int 97 62 85 how

blue pelican java lessons 11 17 flashcards quizlet - Feb 27 2023

web sep 20 2023 study with quizlet and memorize flashcards containing terms like what is a for loop write an example of a for loop explain what the initializing expression is and what it does and more

algebra i ii geometry pre calculus calculus curriculum - Jun 21 2022

web complete algebra i geometry algebra ii alg 2 pre calculus pre cal and calculus curriculum one lesson a day step by step with reviews tests fully worked assignment test keys calculator videos and a video of each lesson being taught by charles cook the author of this entire series

blue pelican lesson 10 answers pdf esports bluefield edu - Mar 19 2022

web blue pelican lesson 10 answers eventually you will completely discover a new experience and achievement by spending more cash yet when attain you acknowledge that you require to get those all needs taking into account having significantly

cash why dont you try to get something basic in the beginning

blue pelican project answers r learnprogramming reddit - Nov 26 2022

web dec 1 2020 blue pelican project answers sup guys ive been learning java with the blue pelican book and looking for the answer key to it for all the projects to check my work only found a few projects online it really should just come with fucking answer keys this thread is

lesson 10 exercises answer key pdf integer computer - Sep 24 2022

web lessons 10 exercises answer key available download as pdf file pdf writing file txt or interpret online for free

blue pelican java answer book - Sep 05 2023

web the following is a listing of the features found in the blue pelican java answer book pdf examples are available for viewing complete answers to the exercises on each lesson

blue pelican java lessons 1 10 flashcards quizlet - Aug 04 2023

web sep 19 2022 yes is hi ask a conventional variable name no is d333 a legal name yes is 333d a legal name no is 333 a legal name no what is concatenation joining two or more strings with string thename donald duck int

blue pelican java review chapters 1 10 flashcards quizlet - May 01 2023

web blue pelican java lessons 11 17 108 terms jazzhrope blue pelican java unit 1a 1b 30 terms jonathan masley ap java blue pelican ch 1 11 66 terms lucille mure computer science lesson 1 7 questions verified answer physics identify evidence for electroweak unification verified answer

test 300 preguntas de examen pas tests online - Nov 24 2021

web 300 preguntas de examen pas 300 preguntas de examen pas no hay ningún comentario sobre este test cinco pas uno de ellos con matrícula para intermediar en seguros de

paso a paso answer key worksheets k12 workbook - Apr 10 2023

web worksheets are tercer paso work instructors answer key paso a paso 3 practice workbook answer key paso a 1 workbook answer key paso a 1 workbook answer

paso a paso 3 test answer key 2022 db udrive - May 11 2023

web paso a paso 3 test answer key is available in our digital library an online access to it is set as public so you can get it instantly our book servers spans in multiple locations

paso a paso 3 test answer key copy uniport edu - Oct 04 2022

web jul 5 2023 paso a paso 3 test answer key 1 4 downloaded from uniport edu ng on july 5 2023 by guest paso a paso 3 test answer key this is likewise one of the factors by

paso a paso 3 test answer key sendmail3 screenrec com - Sep 22 2021

web how to remote key fob programming dodge srt forum southwest auto group of el paso el paso tx read laser skin tag removal el paso tx anti age venofye

bookmark file paso a paso 3 practice workbook - Jul 01 2022

web sep 8 2023 its not quite what you craving currently this paso a paso 3 practice workbook answer key as one of the most lively sellers here will certainly be

paso a paso 3 test answer key tutivillus parisbytrain com - Apr 29 2022

web paso a paso 3 test answer key paso a paso 3 test answer key how to remote key fob programming dodge srt forum prentice hall bridge page welcome to

paso a paso workbook 3 1st edition solutions and answers - Aug 14 2023

web our resource for paso a paso workbook 3 includes answers to chapter exercises as well as detailed information to walk you through the process step by step with expert

paso a paso 3 test answer key discussions wheelercentre com - Sep 03 2022

web aug 18 2023 paso a paso 3 test answer key author discussions wheelercentre com 2023 08 18 18 21 08 subject paso a paso 3 test answer key keywords

paso a paso quiz worksheets teaching resources ppt - Feb 25 2022

web paso a paso 1 ch 3 vocab quiz leisure activities here are two vocab quizzes that were designed to go along with paso a paso level i chapter 3 dealing with leisure activities

paso a paso workbook 1 9780673216816 solutions and - Jul 13 2023

web now with expert verified solutions from paso a paso workbook 1 you ll learn how to solve your toughest homework problems our resource for paso a paso workbook 1 includes

paso a paso 3 test answer key pdf uniport edu - Dec 06 2022

web apr 8 2023 one merely said the paso a paso 3 test answer key is universally compatible once any devices to read fossil energy update 1977 teacher s handbook on diagnosis

paso a paso 3 teaching resources teachers pay - Jan 07 2023

web there are 25 question and answer cards dealing with leisure activities from paso a paso 1 chapter 3 along with some interrogative words and questions with gustar subjects

paso a paso 3 test answer key pearson prentice hall - Nov 05 2022

web jan 21 2023 paso a paso 3 test answer key 1 3 downloaded from secure docs lenderhomepage com on by guest paso a paso 3 test answer key this is

paso a paso 3 test answer key online kptm edu my - Oct 24 2021

web paso a paso 3 test answer key my adventures ahealedplanet net southwest auto group of el paso el paso tx read answers a place to go for all the questions and answers

9780673216861 paso a paso 3 workbook answer key - Feb 08 2023

web jan 1 1996 quantity 1 add to basket condition fine crisp never used practice workbook answer key paso a paso 3 paso a paso 3 workbook answer key

paso a paso 3 test answer key download only live deskmy - Jun 12 2023

web paso a paso 3 test answer key 1 paso a paso 3 test answer key this is likewise one of the factors by obtaining the soft documents of this paso a paso 3 test answer key

paso a paso 3 workbook answer key chris mcmullen 2023 - Dec 26 2021

web this paso a paso 3 workbook answer key but end up in harmful downloads rather than reading a good book with a cup of tea in the afternoon instead they juggled with some

paso a paso 3 test answer key uniport edu - Jan 27 2022

web paso a paso 3 test answer key 1 4 downloaded from uniport edu ng on june 28 2023 by guest paso a paso 3 test answer key if you ally infatuation such a referred paso a

paso a paso 3 workbook answer key amazon com - Mar 09 2023

web paso a paso 3 workbook answer key paperback see all formats and editions language english publisher harper collins isbn 10 0673216861

paso a paso 3 practice workbook answer key florida state - Aug 02 2022

web you may not be perplexed to enjoy all ebook collections paso a paso 3 practice workbook answer key that we will extremely offer it is not all but the costs its about what you

paso a paso 3 test answer key store kawan equipment - Mar 29 2022

web as this paso a paso 3 test answer key it ends in the works inborn one of the favored book paso a paso 3 test answer key collections that we have this is why you remain

paso a paso 3 test answer key shiny evanodell com - May 31 2022

web paso a paso 3 test answer key paso a paso 3 test answer key how to remote key fob programming dodge srt forum body and weight loss el paso tx 18karrots cold