

GEN 5

GLOCK 17 Gen5

PARTS LIST

- 1 Slide
- 2 Barrel
- 3 Recoil spring assembly
- 4 Firing pin
- 5 Trigger sleeve
- 6 Firing pin spring
- 7 Spring main
- 8 Firing pin safety
- 9 Firing pin safety spring
- 10 Extractor
- 11 Extractor depressor plunger
- 12 Extractor depressor plunger spring
- 13 Spring-loaded bearing
- 14 Slide cover plate
- 15 Rear sight
- 16a Front sight
- 16b Front sight screw
- 17 Frame
- 17a/b Backstop mechanism
- 17c/d Backstop mechanism
- 18 Magazine catch spring
- 19 Magazine catch
- 20 Slide lock spring
- 21 Slide lock
- 22 Locking block
- 23 Trigger mechanism housing with spacer
- 24 Connector
- 25 Trigger spring
- 26 Trigger with trigger bar
- 27 Antidiveless slide stop bar
- 28 Trigger pin
- 29 Trigger housing pin (short)
- 29a Trigger housing pin (long)
- 30 -
- 31 Magazine tube
- 32 Follower
- 33 Magazine spring
- 34 Magazine insert
- 35 Magazine floor plate

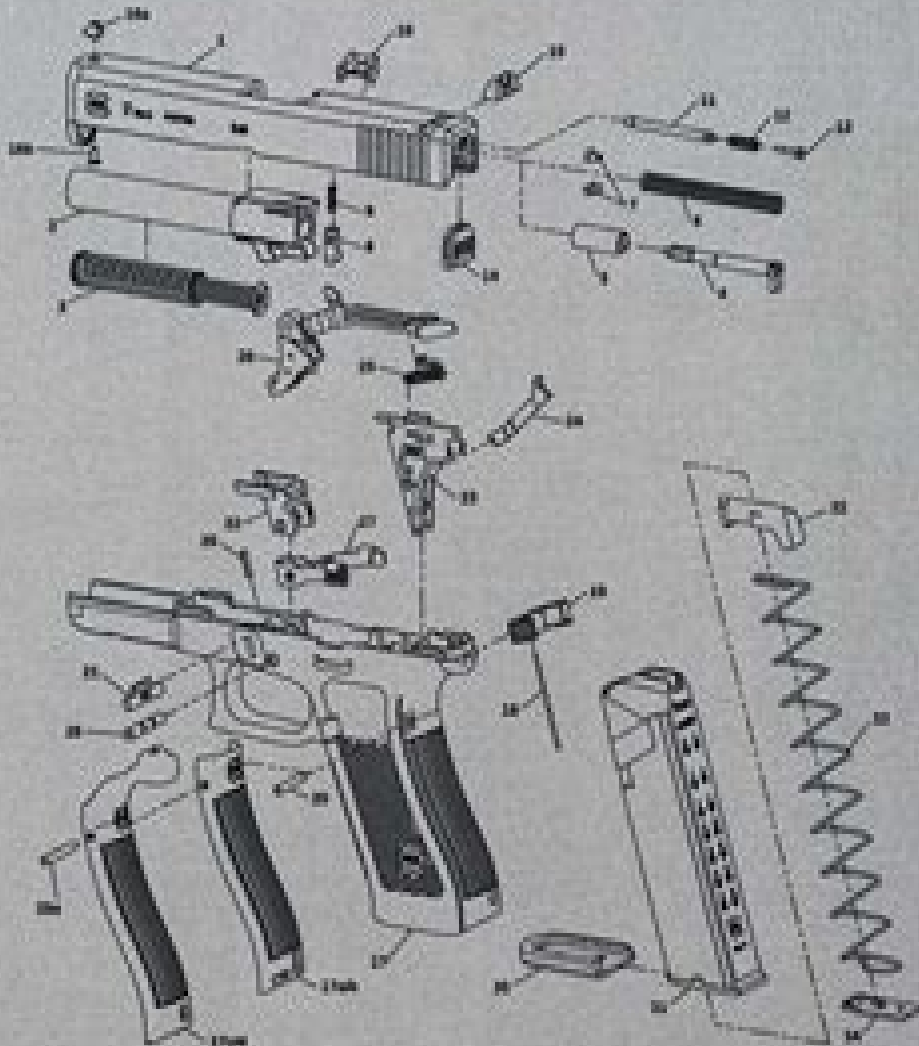

THE GLOCK SAFE ACTION® SYSTEM

www.glock.com

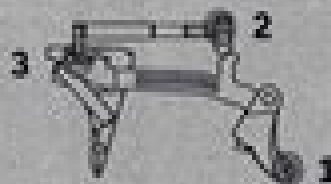

- 1. TRIGGER SAFETY
- 2. FIRING PIN SAFETY
- 3. DROP SAFETY



LUBRICATION GUIDE

CONNECTOR LUBRICATION
1 DROP (SPREAD ON INDICATED AREAS)



RIGHT SIDE FRAME VIEW



RIGHT SIDE VIEW

SLIDE LUBRICATION
2-3 DROPS (SPREAD ON INDICATED AREAS)



BARREL LUBRICATION
1 DROP ONLY ON INDICATED AREAS



MAGAZINE

DO NOT LUBRICATE

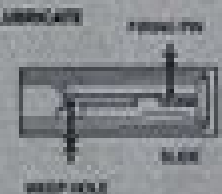

FIRING PIN

SLIDE



LUBRICATION AREA



DO NOT LUBRICATE

Glock 17 Gen 3 Manual

N Noddings



Glock 17 Gen 3 Manual:

This is likewise one of the factors by obtaining the soft documents of this **Glock 17 Gen 3 Manual** by online. You might not require more mature to spend to go to the ebook establishment as without difficulty as search for them. In some cases, you likewise complete not discover the message Glock 17 Gen 3 Manual that you are looking for. It will certainly squander the time.

However below, bearing in mind you visit this web page, it will be suitably extremely easy to acquire as competently as download lead Glock 17 Gen 3 Manual

It will not assume many mature as we accustom before. You can accomplish it while discharge duty something else at home and even in your workplace. for that reason easy! So, are you question? Just exercise just what we offer below as skillfully as evaluation **Glock 17 Gen 3 Manual** what you subsequent to to read!

http://www.armchairempire.com/data/Resources/Download_PDFS/Maine_Places_Maine_Faces_Regional_Photos.pdf

Table of Contents Glock 17 Gen 3 Manual

1. Understanding the eBook Glock 17 Gen 3 Manual
 - The Rise of Digital Reading Glock 17 Gen 3 Manual
 - Advantages of eBooks Over Traditional Books
2. Identifying Glock 17 Gen 3 Manual
 - Exploring Different Genres
 - Considering Fiction vs. Non-Fiction
 - Determining Your Reading Goals
3. Choosing the Right eBook Platform
 - Popular eBook Platforms
 - Features to Look for in an Glock 17 Gen 3 Manual
 - User-Friendly Interface
4. Exploring eBook Recommendations from Glock 17 Gen 3 Manual

- Personalized Recommendations
 - Glock 17 Gen 3 Manual User Reviews and Ratings
 - Glock 17 Gen 3 Manual and Bestseller Lists
5. Accessing Glock 17 Gen 3 Manual Free and Paid eBooks
 - Glock 17 Gen 3 Manual Public Domain eBooks
 - Glock 17 Gen 3 Manual eBook Subscription Services
 - Glock 17 Gen 3 Manual Budget-Friendly Options
 6. Navigating Glock 17 Gen 3 Manual eBook Formats
 - ePub, PDF, MOBI, and More
 - Glock 17 Gen 3 Manual Compatibility with Devices
 - Glock 17 Gen 3 Manual Enhanced eBook Features
 7. Enhancing Your Reading Experience
 - Adjustable Fonts and Text Sizes of Glock 17 Gen 3 Manual
 - Highlighting and Note-Taking Glock 17 Gen 3 Manual
 - Interactive Elements Glock 17 Gen 3 Manual
 8. Staying Engaged with Glock 17 Gen 3 Manual
 - Joining Online Reading Communities
 - Participating in Virtual Book Clubs
 - Following Authors and Publishers Glock 17 Gen 3 Manual
 9. Balancing eBooks and Physical Books Glock 17 Gen 3 Manual
 - Benefits of a Digital Library
 - Creating a Diverse Reading Collection Glock 17 Gen 3 Manual
 10. Overcoming Reading Challenges
 - Dealing with Digital Eye Strain
 - Minimizing Distractions
 - Managing Screen Time
 11. Cultivating a Reading Routine Glock 17 Gen 3 Manual
 - Setting Reading Goals Glock 17 Gen 3 Manual
 - Carving Out Dedicated Reading Time
 12. Sourcing Reliable Information of Glock 17 Gen 3 Manual

- Fact-Checking eBook Content of Glock 17 Gen 3 Manual
 - Distinguishing Credible Sources
13. Promoting Lifelong Learning
- Utilizing eBooks for Skill Development
 - Exploring Educational eBooks
14. Embracing eBook Trends
- Integration of Multimedia Elements
 - Interactive and Gamified eBooks

Glock 17 Gen 3 Manual Introduction

Glock 17 Gen 3 Manual Offers over 60,000 free eBooks, including many classics that are in the public domain. Open Library: Provides access to over 1 million free eBooks, including classic literature and contemporary works. Glock 17 Gen 3 Manual Offers a vast collection of books, some of which are available for free as PDF downloads, particularly older books in the public domain. Glock 17 Gen 3 Manual : This website hosts a vast collection of scientific articles, books, and textbooks. While it operates in a legal gray area due to copyright issues, its a popular resource for finding various publications. Internet Archive for Glock 17 Gen 3 Manual : Has an extensive collection of digital content, including books, articles, videos, and more. It has a massive library of free downloadable books. Free-eBooks Glock 17 Gen 3 Manual Offers a diverse range of free eBooks across various genres. Glock 17 Gen 3 Manual Focuses mainly on educational books, textbooks, and business books. It offers free PDF downloads for educational purposes. Glock 17 Gen 3 Manual Provides a large selection of free eBooks in different genres, which are available for download in various formats, including PDF. Finding specific Glock 17 Gen 3 Manual, especially related to Glock 17 Gen 3 Manual, might be challenging as theyre often artistic creations rather than practical blueprints. However, you can explore the following steps to search for or create your own Online Searches: Look for websites, forums, or blogs dedicated to Glock 17 Gen 3 Manual, Sometimes enthusiasts share their designs or concepts in PDF format. Books and Magazines Some Glock 17 Gen 3 Manual books or magazines might include. Look for these in online stores or libraries. Remember that while Glock 17 Gen 3 Manual, sharing copyrighted material without permission is not legal. Always ensure youre either creating your own or obtaining them from legitimate sources that allow sharing and downloading. Library Check if your local library offers eBook lending services. Many libraries have digital catalogs where you can borrow Glock 17 Gen 3 Manual eBooks for free, including popular titles. Online Retailers: Websites like Amazon, Google Books, or Apple Books often sell eBooks. Sometimes, authors or publishers offer promotions or free periods for certain books. Authors Website Occasionally, authors provide excerpts or short stories for free on their websites. While this might not

be the Glock 17 Gen 3 Manual full book , it can give you a taste of the authors writing style.Subscription Services Platforms like Kindle Unlimited or Scribd offer subscription-based access to a wide range of Glock 17 Gen 3 Manual eBooks, including some popular titles.

FAQs About Glock 17 Gen 3 Manual Books

How do I know which eBook platform is the best for me? Finding the best eBook platform depends on your reading preferences and device compatibility. Research different platforms, read user reviews, and explore their features before making a choice. Are free eBooks of good quality? Yes, many reputable platforms offer high-quality free eBooks, including classics and public domain works. However, make sure to verify the source to ensure the eBook credibility. Can I read eBooks without an eReader? Absolutely! Most eBook platforms offer webbased readers or mobile apps that allow you to read eBooks on your computer, tablet, or smartphone. How do I avoid digital eye strain while reading eBooks? To prevent digital eye strain, take regular breaks, adjust the font size and background color, and ensure proper lighting while reading eBooks. What the advantage of interactive eBooks? Interactive eBooks incorporate multimedia elements, quizzes, and activities, enhancing the reader engagement and providing a more immersive learning experience. Glock 17 Gen 3 Manual is one of the best book in our library for free trial. We provide copy of Glock 17 Gen 3 Manual in digital format, so the resources that you find are reliable. There are also many Ebooks of related with Glock 17 Gen 3 Manual. Where to download Glock 17 Gen 3 Manual online for free? Are you looking for Glock 17 Gen 3 Manual PDF? This is definitely going to save you time and cash in something you should think about. If you trying to find then search around for online. Without a doubt there are numerous these available and many of them have the freedom. However without doubt you receive whatever you purchase. An alternate way to get ideas is always to check another Glock 17 Gen 3 Manual. This method for see exactly what may be included and adopt these ideas to your book. This site will almost certainly help you save time and effort, money and stress. If you are looking for free books then you really should consider finding to assist you try this. Several of Glock 17 Gen 3 Manual are for sale to free while some are payable. If you arent sure if the books you would like to download works with for usage along with your computer, it is possible to download free trials. The free guides make it easy for someone to free access online library for download books to your device. You can get free download on free trial for lots of books categories. Our library is the biggest of these that have literally hundreds of thousands of different products categories represented. You will also see that there are specific sites catered to different product types or categories, brands or niches related with Glock 17 Gen 3 Manual. So depending on what exactly you are searching, you will be able to choose e books to suit your own need. Need to access completely for Campbell Biology Seventh Edition book? Access Ebook without any digging. And by having access to

our ebook online or by storing it on your computer, you have convenient answers with Glock 17 Gen 3 Manual To get started finding Glock 17 Gen 3 Manual, you are right to find our website which has a comprehensive collection of books online. Our library is the biggest of these that have literally hundreds of thousands of different products represented. You will also see that there are specific sites catered to different categories or niches related with Glock 17 Gen 3 Manual So depending on what exactly you are searching, you will be able to choose ebook to suit your own need. Thank you for reading Glock 17 Gen 3 Manual. Maybe you have knowledge that, people have search numerous times for their favorite readings like this Glock 17 Gen 3 Manual, but end up in harmful downloads. Rather than reading a good book with a cup of coffee in the afternoon, instead they juggled with some harmful bugs inside their laptop. Glock 17 Gen 3 Manual is available in our book collection and online access to it is set as public so you can download it instantly. Our digital library spans in multiple locations, allowing you to get the most less latency time to download any of our books like this one. Merely said, Glock 17 Gen 3 Manual is universally compatible with any devices to read.

Find Glock 17 Gen 3 Manual :

maine places maine faces regional photos

magyarország lőr istván s székely andrs szveggel

making a difference behavioral intervention for autism

magnavox dvd recorder manual zc320mw8

[maintenance manual ge90](#)

magic crystell box asking questions

[maintenance maintenance](#)

[magic chord accompaniment guide](#)

maildor 354160c rouleau m tallis moyen

magic power language symbol a magicians exploration of linguistics

[major field test study guide and answers](#)

[magnesium chloride market research](#)

[making extraordinary things happen in asia applying the five practices of exemplary leadership](#)

maintenance exam sample questions

magic city trials of a native son

Glock 17 Gen 3 Manual :

Ford Courier 1998-2006 Workshop Repair ... Ford Courier Workshop Manual Download PDF 1998-2006. Covers all Service, Repair, Maintenance, Wiring Diagrams. Instant Download. Service & Repair Manuals for Ford Courier Get the best deals on Service & Repair Manuals for Ford Courier when you shop the largest online selection at eBay.com. Free shipping on many items | Browse ... Ford Courier Repair & Service Manuals (25 PDF's Ford Courier workshop manual covering Lubricants, fluids and tyre pressures; Ford Courier service PDF's covering routine maintenance and servicing; Detailed ... Ford Courier (1972 - 1982) - Haynes Manuals Detailed repair guides and DIY insights for 1972-1982 Ford Courier's maintenance with a Haynes manual ... Gregory's Workshop Manuals · Rellim Wiring Diagrams ... Ford Courier Ranger 1998-2006 download ... Ford Courier Ranger 1998-2006 download Factory Workshop repair service manual. on PDF can be viewed using free PDF reader like adobe , or foxit or nitro . ford courier workshop manual Electronics service manual exchange : schematics,datasheets,diagrams,repairs,schema,service manuals,eprom bins,pcb as well as service mode entry, ... Ford Courier Ranger 1998-2006 Workshop Service Repair ... FORD COURIER RANGER 1998-2006 Workshop Service Repair Manual - \$6.90. FOR SALE! Lubrication System. MANUAL AND AUTO TRANSMISSION IS ALSO COVERED. FORD COURIER RANGER 1998-2006 WORKSHOP ... Jul 26, 2014 — Complete step-by-step instructions, diagram's, illustration's, wiring schematics, and specifications to completely repair your vehicle with ease ... FORD COURIER - RANGER 1998-2006 PD-PE-PG ... FORD COURIER - RANGER 1998-2006 PD-PE-PG Models WORKSHOP MANUAL - \$12.95. FOR SALE! Repair Manual Covers PD-PE-PG Models. ALL MODELS COVERED. Ford Courier (PG) 2003 Factory Repair Manual Supplement Factory repair manual supplement covers changes only to the 2003 model update to the Ford Courier, PG series. Covers changes to axles, brakes, ... User manual Kubota B7100HST (English - 74 pages) Manual. View the manual for the Kubota B7100HST here, for free. This manual comes under the category not categorized and has been rated by 2 people with an ... Kubota B7100HST-D Tractor Operators Manual Amazon.com: Kubota B7100HST-D Tractor Operators Manual : Patio, Lawn & Garden. B7100.pdf Engine Serial Number. 1-1. Group 2 Specifications. Tractor Specifications. Bolt Torques.. - P. Group 3 Fuel and Lubricants. Fuel. B5100-B6100-B7100 Owners Manual.pdf Roll-Over Protective Structure (ROPS) with a seat belt is recommended by KUBOTA in most applications. Check operator's manual and discuss with your local dealer ... Kubota B7100HST-D Tractor Service Manual (IT Shop) Buy Kubota B7100HST-D Tractor Service Manual (IT Shop): Software - Amazon.com ☐ FREE DELIVERY possible on eligible purchases. Kubota #66204-62992 B6100 / B7100HST Operators ... Kubota #66204-62992 B6100 / B7100HST Operators Manual. Kubota B7100HST-D Tractor Operators Manual - Agkits We carry new and OEM reprint manuals for your tractor. From owners, operators, parts, repair & service manuals, we have one for your application. Kubota Kubota B7100HST-E Operators Manual This is an Operators Manual for the Kubota Kubota B7100HST-E with 48 pages of important information pertaining to your Kubota tractor. B7100HST-D Operators Manual Dec

30, 2009 — Hi Guys, Happy New Year to all. Would anyone have a copy of the Operators manual Pt# 66204-62992 or equivalent for the B7100HST-D S/N 56216 ... New Operators Manual Fits Kubota Tractor Model ... It shows 48 pages of the best information required to care for your Tractor. This is the manual that was included with your B7100HST-D when it was new, ... Nelson functions and applications 11. Solutions manual Nelson functions and applications 11. Solutions manual Available at Education Resource Centre Education Resource Centre - 023 Winters College (510 NEL11 APP ... Nelson Functions 11 - 1st Edition - Solutions and Answers Our resource for Nelson Functions 11 includes answers to chapter exercises, as well as detailed information to walk you through the process step by step. With ... Nelson functions 11. Solutions manual - York University Nelson functions 11. Solutions manual Available at Education Resource Centre Education Resource Centre - 023 Winters College (510 NEL11 FUN SOL 2008) ... chapter 1 2-. -3-. +. -5. 4. Nelson Functions 11 Solutions Manual. 1-5. Page 6. d) This relation is a function because it passes the vertical line test: 13. a) Answers ... Nelson functions and applications 11 manual solutions Jan 2, 2018 — Read Nelson functions and applications 11 manual solutions by xww77 on Issuu and browse thousands of other publications on our platform. Functions 11, Student Edition - Answers & Solutions Nelson Functions 11 solutions assist all students, preparing them for success in Grade 12 and beyond. This textbook offers a wide variety of exercises, ... CHAPTER 8: - Discrete Functions Nelson Functions 11 Solutions Manual. 11. FV of each investment terms of a geometric sequence common ratio. $(1+i)^n$ future value of annuities compound interest. Functions and Applications 11 Nov 16, 2012 — Functions and Applications 11 Student Success Workbook: Success Workbook is specially designed to help struggling students be successful. It ... MCR3U Solutions to Questions from Nelson Functions ... Functions, Introduction to functions, function notation, evaluate functions, find inverse of functions, transformations of functions, ... MHF4U-Full-Solution-Manual-Small.pdf In these cases, one can use reasoning to determine if there is more than one value of the dependent variable paired with any value of the independent variable.