

TERMINOLOGIE DU CHARGEUR

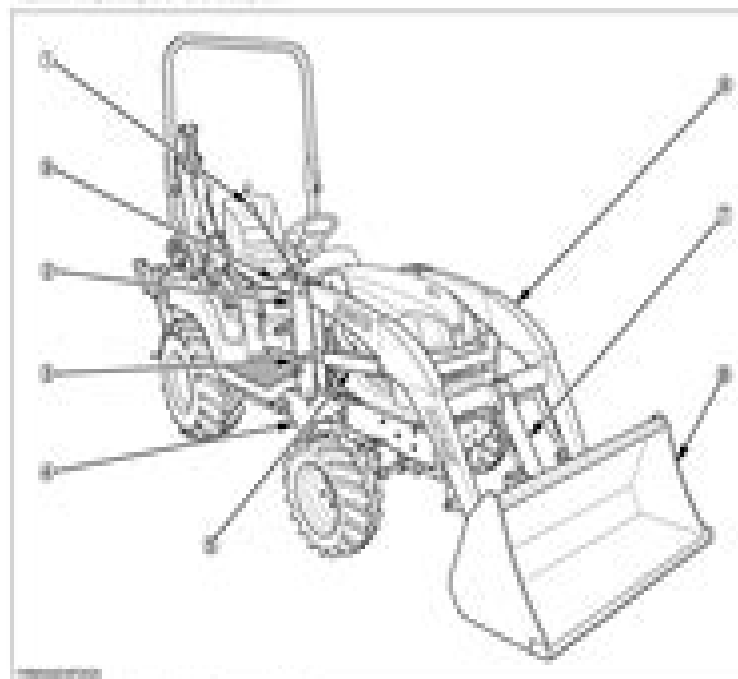

Terminologie

- 01 Cadre de stabilité de charge
- 02 Ane de levage
- 03 Axe de montage
- 04 Bras de levage
- 05 Cadre de base
- 06 Cadre de montage
- 07 Plateau
- 08 Cadre de centre de base
- 09 Cadre de montage
- 10 Cadre de montage

DONNÉES TECHNIQUES DE LA PELLE RÉTROCAVEUSE

SPECIFICATIONS DE LA RÉTROCAVEUSE

■ Dimensions

Axe		RT501
Hauteur de transport	04	1 710 mm (69,1 po.)
Écartement des stabilisateurs - transport	05	1 200 mm (47,2 po.)
Écartement au sol	03	240 mm (9,4 po.)
Largeur totale	02	1 120 mm (44,1 po.)
Profondeur de chargement max.	01	1 000 mm (39,4 po.)
Profondeur de chargement à l'horizontale	06	1 040 mm (40,9 po.)
Profondeur de chargement à l'oblique	07	1 000 mm (39,4 po.)
Hauteur d'opération - complètement levé	08	2 220 mm (87,4 po.)
Hauteur de chargement	09	1 020 mm (40,1 po.)
Distance de chargement	10	1 010 mm (39,7 po.)
Distance avant depuis l'axe de pivot	04	2 010 mm (79,1 po.)
Axe de pivot jusqu'à l'axe de base	05	1 200 mm (47,2 po.)
Rotation du pivot	01	140 degrés
Écartement des stabilisateurs arrière au repos	05	1 040 mm (40,9 po.)
Angle de déplacement arrière (SAE J-1104)	04,5	20,7 degrés
Angle de pivot à l'avant	03	11 degrés
Art de rotation		140 degrés

NOTES

- Ces spécifications ont été mesurées avec le tracteur BA250 LUBOTL. (Dimension des pneus Avant : 18 x 13,6-8 Arrière : 26 x 12,00-12)

Kubota Bx25d Owners Manual

S Marginson



Kubota Bx25d Owners Manual:

The Engaging Realm of Kindle Books: A Comprehensive Guide Unveiling the Advantages of E-book Books: A Realm of Ease and Versatility Kindle books, with their inherent portability and simplicity of availability, have liberated readers from the constraints of hardcopy books. Gone are the days of lugging bulky novels or meticulously searching for particular titles in shops. E-book devices, sleek and lightweight, seamlessly store an extensive library of books, allowing readers to indulge in their preferred reads anytime, everywhere. Whether commuting on a bustling train, lounging on a sunny beach, or just cozying up in bed, Kindle books provide an exceptional level of ease. A Reading World Unfolded: Discovering the Vast Array of Kindle Kubota Bx25d Owners Manual Kubota Bx25d Owners Manual The Kindle Store, a digital treasure trove of literary gems, boasts an extensive collection of books spanning diverse genres, catering to every readers taste and choice. From gripping fiction and thought-provoking non-fiction to classic classics and modern bestsellers, the Kindle Shop offers an unparalleled abundance of titles to explore. Whether seeking escape through engrossing tales of imagination and adventure, diving into the depths of historical narratives, or broadening ones knowledge with insightful works of scientific and philosophical, the Kindle Store provides a gateway to a bookish world brimming with limitless possibilities. A Transformative Factor in the Literary Scene: The Enduring Impact of Kindle Books Kubota Bx25d Owners Manual The advent of Kindle books has undoubtedly reshaped the literary scene, introducing a paradigm shift in the way books are published, distributed, and consumed. Traditional publishing houses have embraced the online revolution, adapting their strategies to accommodate the growing demand for e-books. This has led to a rise in the accessibility of Kindle titles, ensuring that readers have entry to a wide array of literary works at their fingers. Moreover, Kindle books have equalized access to books, breaking down geographical limits and offering readers worldwide with similar opportunities to engage with the written word. Irrespective of their place or socioeconomic background, individuals can now engross themselves in the captivating world of books, fostering a global community of readers. Conclusion: Embracing the E-book Experience Kubota Bx25d Owners Manual Kindle books Kubota Bx25d Owners Manual, with their inherent ease, flexibility, and vast array of titles, have certainly transformed the way we experience literature. They offer readers the freedom to explore the limitless realm of written expression, anytime, everywhere. As we continue to travel the ever-evolving digital scene, Kindle books stand as testament to the enduring power of storytelling, ensuring that the joy of reading remains reachable to all.

http://www.armchairempire.com/About/detail/default.aspx/Hay_Group_Guide_Chart.pdf

Table of Contents Kubota Bx25d Owners Manual

1. Understanding the eBook Kubota Bx25d Owners Manual
 - The Rise of Digital Reading Kubota Bx25d Owners Manual
 - Advantages of eBooks Over Traditional Books
2. Identifying Kubota Bx25d Owners Manual
 - Exploring Different Genres
 - Considering Fiction vs. Non-Fiction
 - Determining Your Reading Goals
3. Choosing the Right eBook Platform
 - Popular eBook Platforms
 - Features to Look for in an Kubota Bx25d Owners Manual
 - User-Friendly Interface
4. Exploring eBook Recommendations from Kubota Bx25d Owners Manual
 - Personalized Recommendations
 - Kubota Bx25d Owners Manual User Reviews and Ratings
 - Kubota Bx25d Owners Manual and Bestseller Lists
5. Accessing Kubota Bx25d Owners Manual Free and Paid eBooks
 - Kubota Bx25d Owners Manual Public Domain eBooks
 - Kubota Bx25d Owners Manual eBook Subscription Services
 - Kubota Bx25d Owners Manual Budget-Friendly Options
6. Navigating Kubota Bx25d Owners Manual eBook Formats
 - ePub, PDF, MOBI, and More
 - Kubota Bx25d Owners Manual Compatibility with Devices
 - Kubota Bx25d Owners Manual Enhanced eBook Features
7. Enhancing Your Reading Experience
 - Adjustable Fonts and Text Sizes of Kubota Bx25d Owners Manual
 - Highlighting and Note-Taking Kubota Bx25d Owners Manual
 - Interactive Elements Kubota Bx25d Owners Manual
8. Staying Engaged with Kubota Bx25d Owners Manual

- Joining Online Reading Communities
 - Participating in Virtual Book Clubs
 - Following Authors and Publishers Kubota Bx25d Owners Manual
9. Balancing eBooks and Physical Books Kubota Bx25d Owners Manual
- Benefits of a Digital Library
 - Creating a Diverse Reading Collection Kubota Bx25d Owners Manual
10. Overcoming Reading Challenges
- Dealing with Digital Eye Strain
 - Minimizing Distractions
 - Managing Screen Time
11. Cultivating a Reading Routine Kubota Bx25d Owners Manual
- Setting Reading Goals Kubota Bx25d Owners Manual
 - Carving Out Dedicated Reading Time
12. Sourcing Reliable Information of Kubota Bx25d Owners Manual
- Fact-Checking eBook Content of Kubota Bx25d Owners Manual
 - Distinguishing Credible Sources
13. Promoting Lifelong Learning
- Utilizing eBooks for Skill Development
 - Exploring Educational eBooks
14. Embracing eBook Trends
- Integration of Multimedia Elements
 - Interactive and Gamified eBooks

Kubota Bx25d Owners Manual Introduction

Free PDF Books and Manuals for Download: Unlocking Knowledge at Your Fingertips In today's fast-paced digital age, obtaining valuable knowledge has become easier than ever. Thanks to the internet, a vast array of books and manuals are now available for free download in PDF format. Whether you are a student, professional, or simply an avid reader, this treasure trove of downloadable resources offers a wealth of information, conveniently accessible anytime, anywhere. The advent of online libraries and platforms dedicated to sharing knowledge has revolutionized the way we consume information. No longer confined to physical libraries or bookstores, readers can now access an extensive collection of digital books and

manuals with just a few clicks. These resources, available in PDF, Microsoft Word, and PowerPoint formats, cater to a wide range of interests, including literature, technology, science, history, and much more. One notable platform where you can explore and download free Kubota Bx25d Owners Manual PDF books and manuals is the internet's largest free library. Hosted online, this catalog compiles a vast assortment of documents, making it a veritable goldmine of knowledge. With its easy-to-use website interface and customizable PDF generator, this platform offers a user-friendly experience, allowing individuals to effortlessly navigate and access the information they seek. The availability of free PDF books and manuals on this platform demonstrates its commitment to democratizing education and empowering individuals with the tools needed to succeed in their chosen fields. It allows anyone, regardless of their background or financial limitations, to expand their horizons and gain insights from experts in various disciplines. One of the most significant advantages of downloading PDF books and manuals lies in their portability. Unlike physical copies, digital books can be stored and carried on a single device, such as a tablet or smartphone, saving valuable space and weight. This convenience makes it possible for readers to have their entire library at their fingertips, whether they are commuting, traveling, or simply enjoying a lazy afternoon at home. Additionally, digital files are easily searchable, enabling readers to locate specific information within seconds. With a few keystrokes, users can search for keywords, topics, or phrases, making research and finding relevant information a breeze. This efficiency saves time and effort, streamlining the learning process and allowing individuals to focus on extracting the information they need. Furthermore, the availability of free PDF books and manuals fosters a culture of continuous learning. By removing financial barriers, more people can access educational resources and pursue lifelong learning, contributing to personal growth and professional development. This democratization of knowledge promotes intellectual curiosity and empowers individuals to become lifelong learners, promoting progress and innovation in various fields. It is worth noting that while accessing free Kubota Bx25d Owners Manual PDF books and manuals is convenient and cost-effective, it is vital to respect copyright laws and intellectual property rights. Platforms offering free downloads often operate within legal boundaries, ensuring that the materials they provide are either in the public domain or authorized for distribution. By adhering to copyright laws, users can enjoy the benefits of free access to knowledge while supporting the authors and publishers who make these resources available. In conclusion, the availability of Kubota Bx25d Owners Manual free PDF books and manuals for download has revolutionized the way we access and consume knowledge. With just a few clicks, individuals can explore a vast collection of resources across different disciplines, all free of charge. This accessibility empowers individuals to become lifelong learners, contributing to personal growth, professional development, and the advancement of society as a whole. So why not unlock a world of knowledge today? Start exploring the vast sea of free PDF books and manuals waiting to be discovered right at your fingertips.

FAQs About Kubota Bx25d Owners Manual Books

1. Where can I buy Kubota Bx25d Owners Manual books? Bookstores: Physical bookstores like Barnes & Noble, Waterstones, and independent local stores. Online Retailers: Amazon, Book Depository, and various online bookstores offer a wide range of books in physical and digital formats.
2. What are the different book formats available? Hardcover: Sturdy and durable, usually more expensive. Paperback: Cheaper, lighter, and more portable than hardcovers. E-books: Digital books available for e-readers like Kindle or software like Apple Books, Kindle, and Google Play Books.
3. How do I choose a Kubota Bx25d Owners Manual book to read? Genres: Consider the genre you enjoy (fiction, non-fiction, mystery, sci-fi, etc.). Recommendations: Ask friends, join book clubs, or explore online reviews and recommendations. Author: If you like a particular author, you might enjoy more of their work.
4. How do I take care of Kubota Bx25d Owners Manual books? Storage: Keep them away from direct sunlight and in a dry environment. Handling: Avoid folding pages, use bookmarks, and handle them with clean hands. Cleaning: Gently dust the covers and pages occasionally.
5. Can I borrow books without buying them? Public Libraries: Local libraries offer a wide range of books for borrowing. Book Swaps: Community book exchanges or online platforms where people exchange books.
6. How can I track my reading progress or manage my book collection? Book Tracking Apps: Goodreads, LibraryThing, and Book Catalogue are popular apps for tracking your reading progress and managing book collections. Spreadsheets: You can create your own spreadsheet to track books read, ratings, and other details.
7. What are Kubota Bx25d Owners Manual audiobooks, and where can I find them? Audiobooks: Audio recordings of books, perfect for listening while commuting or multitasking. Platforms: Audible, LibriVox, and Google Play Books offer a wide selection of audiobooks.
8. How do I support authors or the book industry? Buy Books: Purchase books from authors or independent bookstores. Reviews: Leave reviews on platforms like Goodreads or Amazon. Promotion: Share your favorite books on social media or recommend them to friends.
9. Are there book clubs or reading communities I can join? Local Clubs: Check for local book clubs in libraries or community centers. Online Communities: Platforms like Goodreads have virtual book clubs and discussion groups.
10. Can I read Kubota Bx25d Owners Manual books for free? Public Domain Books: Many classic books are available for free as they're in the public domain. Free E-books: Some websites offer free e-books legally, like Project Gutenberg or Open Library.

Find Kubota Bx25d Owners Manual :

hay group guide chart

[haynes repair manual jeep cherokee country](#)

[haynes manual ford 02 taurus](#)

haynes 3 series repair manual

haynes bronco manual

[haynes forester repair manual](#)

[haynes manual vauxhall zafira 2002](#)

[haynes 1975 1979 honda gl 1000 gold wing owners service manual 309 920](#)

[haynes repair manual fiat grande punto](#)

haynes manual ford focus petrol

[haynes manual mini 1275 gt](#)

[haynes manual porsche 924](#)

[haynes manual citroen xsara picasso 2002](#)

haynes repair manual dodge truck

haynes mini renovation manual 1986 2000

Kubota Bx25d Owners Manual :

graphing exponential functions matching activity algebra accents - Aug 08 2022

web activity students will are given 18 exponential functions on a student recording sheet they are also given 2 pages of graphs each labeled with a letter students will match the equation to its graph with or without a graphing calculator answer key provided this purchase is for one teacher only

[exponential matching key orientation sutd edu sg](#) - Sep 21 2023

web exponential matching key exponential matching key algebra 2 exponential matching activity answer key graphing exponential functions worksheet rpdp exponential matching key 198 74 57 167 graphing exponential and logarithmic functions matching 3 4 properties of exponential functions worksheet match that function the charles a

[resolving dissonance a great wordpress com site](#) - Mar 03 2022

web feb 9 2013 we would like to show you a description here but the site won t allow us

[6 1 exponential functions college algebra 2e openstax](#) - May 17 2023

web identifying exponential functions when exploring linear growth we observed a constant rate of change a constant number by which the output increased for each unit increase in input for example in the equation $f(x) = 3x + 4$ the slope tells us the output increases by 3 each time the input increases by 1

[solving exponential equations using logarithms khan academy](#) - Oct 10 2022

web the key to solving exponential equations lies in logarithms let's take a closer look by working through some examples solving exponential equations of the form $a \cdot b^x = d$

[module 3 linear and exponential functions khan academy](#) - Apr 16 2023

web in this module students extend their study of functions to include function notation and the concepts of domain and range they explore many examples of functions and their graphs focusing on the contrast between linear and exponential functions

[a handful of key packers starters inactive vs lions on thanksgiving](#) - Oct 30 2021

web 3 hours ago campbell was inactive for the packers first matchup against the lions this season week 4 at lambeau field the lions who rank fifth in the nfl in rushing and form the foundation of their offense on the ground game finished with 211 yards against the packers in september tailback david montgomery had three rushing touchdowns

[exponential function matching teaching resources tpt](#) - Jul 19 2023

web objective the students will match the graphs of exponential functions with their equation by noticing key features strong standards teks a.9.d.ccss.hsf.if.c.7 activity students will be given 18 exponential functions on a student recording sheet they are also given 2 pages of graphs each labeled with a letter

[exponentialmatchingkey cyberlab sutd.edu.sg](#) - Sep 09 2022

web 1 exponentialmatchingkey eventually you will unconditionally discover a other experience and deed by spending more cash nevertheless when do you assume that you require to

exponential matching key pdf - Oct 22 2023

web exponential matching key advancing maths for aqa pure core 3 4 2nd edition c3 c4 oct 29 2022 including clear explanations detailed worked examples and self assessment tests this textbook meets the 2004 aqa specifications and builds on good gcse practice by emphasising applications and providing coverage of the key concepts

exponential matching key pdf - Jan 01 2022

web exponential matching key wage and employment growth act of 1999 may 25 2020 international contributions with an aim is to increase awareness of the problems associated with match fixing and the degree to which key agents in sport particularly young people are vulnerable the contributions are

algebra 2 exponential matching activity answer key - May 05 2022

web the seventeen experiments can be used to introduce develop and reinforce basic algebra concepts such as slope intercept and equation of a line independent and dependent variables the properties of a linear function and the interconnections between the equation of a function and its graph

results for exponential functions matching ppt - Mar 15 2023

web objective the students will match the graphs of exponential functions with their equation by noticing key features strong standards teks a 9 d ccss hsf if c 7 e activity students will are given 18 exponential functions on a student recording sheet they are also given 2 pages of graphs each labeled with a letter

lesson 4 5 answer key ap precalculus calc medic exponential match - Dec 12 2022

web today we ll look at the graphs of these exponential functions and use what we know about transformations to match the graphs to their equations 2 quot keyave exponential always 2 increasing up functions either or o i decreasing up no *exponential matching key precalculus pdf cie advances asme* - Feb 02 2022

web exponential matching key precalculus 2 downloaded from cie advances asme org on 2022 07 26 by guest way that highlights the coherence between modules and topics the guidebooks allow teachers to obtain a firm grasp on what it is that students should master during the year

4 2e exercises graphs of exponential functions - Nov 11 2022

web b match graphs with equations c graph basic exponential functions d graph shifts of exponential functions e graph reflections and stretches of exponential functions f construct an equation given a description g construct an equation given a graph h practice with exponent properties

properties of exponents matching teaching resources ppt - Jan 13 2023

web this fun matching activity allows students to practice applying the exponent rules to 12 challenging expression the properties of exponents included are multiplying with same base dividing with same base negative exponents power to a power zero exponents there are given twelve tickets cards each with the face of a cartoon hero

when math happens - Aug 20 2023

web sep 9 2014 we would like to show you a description here but the site won t allow us

rational exponents matching teaching resources ppt - Feb 14 2023

web created by playful pythagoras in this self checking google sheets digital matching activity students will convert each expression with fractional exponents into a simplified radical your students will love watching the connecting lines appear as they correctly match each expression to its radical form

ex match exponential functions to graphs youtube - Jun 18 2023

web dec 21 2011 this video explains how to match equations of exponential function to graphs of exponential functions

video library mathispower4u comsearch

[exponential functions calc medic](#) - Jun 06 2022

web a key skill is determining if a situation exhibits exponential change and whether that change is growth or decay as you are monitoring and debriefing continue to formatively assess the main goal of this unit which is for students to be able to explain how the pattern in an exponential function is different from the pattern in a linear function

[how to match exponential graphs math wonderhowto](#) - Jul 07 2022

web jul 23 2010 match exponential graphs this video tutorial belongs to the education category which is going to show you how to match exponential graphs the video shows two graph sheets with three graphs marked a to f on each sheet and six equations it starts off with matching the basic function $y = 2^x$ to the power x if you plug in zero for x you

[6 8 fitting exponential models to data openstax](#) - Apr 04 2022

web knowing the behavior of exponential functions in general allows us to recognize when to use exponential regression so let s review exponential growth and decay recall that exponential functions have the form $y = a \cdot b^x$ or $y = a \cdot e^{kx}$

[algebra 2 exponential matching activity answer key 2023 cie](#) - Nov 30 2021

web algebra 2 exponential matching activity answer key algebra 2 exponential matching activity answer key 2 downloaded from cie advances asme org on 2020 09 04 by guest abilities and learning styles many of these activities are self correcting adding interest for students and saving you time this book provides dozens of activities that

[matriculant 2014 exam timetable pdf ezraclark com](#) - May 12 2023

web web matriculant 2014 exam timetable 2014 higher school certificate examination timetable year 12 april 23rd 2018 2014 higher school certificate examination timetable monday 13 october to wednesday 5 november 2014 hsc timetable week 1 approximate finishing time assessment

[matriculant 2014 exam timetable pdf full pdf features kualumni](#) - Jun 13 2023

web unprotected true pdf from sales chinesestandard net this standard specifies the requirements test methods marking of student s articles this standard applies to learning articles which are used by students

[final examinations timetable for matriculants of 2014 pdf full](#) - Sep 04 2022

web jun 6 2023 right here we have countless book final examinations timetable for matriculants of 2014 pdf and collections to check out we additionally allow variant types and moreover type of the books to browse

[matriculant 2014 exam timetable uniport edu ng](#) - Apr 11 2023

web aug 9 2023 if you want to download and install the matriculant 2014 exam timetable it is utterly easy then past currently we extend the member to purchase and create bargains to download and install matriculant 2014 exam timetable

therefore simple grammar writing student textbook grade 6 2nd edition 2014 stephen hake 2013 07 05

matriculant 2014 exam timetable top ic edu - Oct 05 2022

web jun 12 2023 matriculant 2014 exam timetable is accessible in our text gathering an online access to it is set as public so you can get it instantaneously along with instructions you could savor the moment is matriculant 2014 exam timetable below
download full matric exam timetable 2022 the south african - Jan 28 2022

web oct 31 2022 there are a total of 923 460 matric candidates registered to write the 2022 exams the last paper will be on 7 december the matric pass rate has only been above 80 once in the past five years

Öğretim yılı 4 sınıflar ii dönem sınav tarihleri - Feb 26 2022

web 2022 2023 Öğretim yılı 4 sınıflar ii dönem sınav tarihleri tablosu dersler 1 genel sınav ii genel sınav matematik 31 mart cuma 2 ders 2 haziran cuma fen bilimleri 24 28 nisan haftası 16 mayıs salı türkçe ve kompozisyon 27 mart pazartesi 2 ders 31 mayıs Çarşamba sosyal bilgiler 20 24 mart haftası 3 7 nisan haftası din kültürü ve ahlak bilgisi 8 mart

matriculant 2014 exam timetable neurocme med ucla edu - Feb 09 2023

web matriculant 2014 exam timetable 1 matriculant 2014 exam timetable getting the books matriculant 2014 exam timetable now is not type of inspiring means you could not deserted going in the same way as ebook hoard or library or borrowing from your links to read them this is an entirely simple means to specifically get guide by on line

pdf matriculant 2014 exam timetable cyberlab sutd edu sg - Aug 15 2023

web matriculant 2014 exam timetable textbook of female urology and urogynecology two volume set sep 17 2021 featuring contributions by an international team of the world s experts in urology and gynecology this fourth edition reinforces its status as the classic comprehensive resource on

matriculant 2014 exam timetable host sbtexas - Apr 30 2022

web may 27 2023 it will hugely ease you to see tutorial matriculant 2014 exam timetable as you such as you could quickly download this matriculant 2014 exam timetable after getting deal access the matriculant 2014 exam timetable join that we have the resources for here and check out the link

matriculant 2014 exam timetable help environment harvard edu - Jul 14 2023

web merely said the matriculant 2014 exam timetable is universally compatible later than any devices to read veterinary medical school admission requirements vmsar association of american veterinary medical colleges 2014 04 the choice of a career in veterinary medicine must begin with early preparation for selective admissions

matriculant 2014 exam timetable uniport edu ng - Dec 07 2022

web matriculant 2014 exam timetable 2 18 downloaded from uniport edu ng on july 2 2023 by guest utilizing block scheduling and traditional scheduling models differ in achievement levels on the five georgia end ofcourse exams eoct and

the georgia high school graduation writing test ghswt at two high schools in rural south georgia

final examinations timetable for matriculants of 2014 pdf - Aug 03 2022

web web matriculant 2014 exam timetable matriculant 2014 exam timetable matric final exam timetable how to pass matric exam timetables acca qualification students final examinations timetable for matriculants of 2014 pdf web mar 11 2023 web statement matric final examination 2014 timetable south africa that you are 2

matriculant 2014 exam timetable uniport edu ng - Jun 01 2022

web mar 31 2023 matriculant 2014 exam timetable 1 18 downloaded from uniport edu ng on march 31 2023 by guest matriculant 2014 exam timetable right here we have countless ebook matriculant 2014 exam timetable and collections to check out we additionally allow variant types and in addition to type of the books to browse the suitable book fiction

cbse schedule 2014 class 10th exam dates the financial - Mar 30 2022

web jan 1 2014 the cbse had promised to announce the exam schedule in the last week of december unlike last year when it came out later the cbse board exams for class 10 will begin on march 1 with english

matriculant 2014 exam timetable qa nuevesolutions com - Jan 08 2023

web you have remained in right site to begin getting this info get the matriculant 2014 exam timetable connect that we provide here and check out the link you could buy guide matriculant 2014 exam timetable or get it as soon as feasible you could speedily download this matriculant 2014 exam timetable after getting deal

matriculant 2014 exam timetable pdf book - Mar 10 2023

web matriculant 2014 exam timetable pdf is available in our book collection an online access to it is set as public so you can get it instantly our book servers spans in multiple locations allowing you to get the most less latency time to download

basic education matric exam timetable amended here are - Dec 27 2021

web sep 15 2021 matric learners were scheduled to sit down for their first exam on 1 november however the department has changed the date to 27 october this means there s now some slight changes to the

final examinations timetable for matriculants of 2014 pdf book - Jul 02 2022

web web matriculant 2014 exam timetable exam timetables cambridge assessment international may 2nd 2018 schools need to ensure they are using the correct version of the timetable view the exam timetables for all exams in all of the

matriculant 2014 exam timetable uniport edu ng - Nov 06 2022

web mar 18 2023 matriculant 2014 exam timetable 1 12 downloaded from uniport edu ng on march 18 2023 by guest matriculant 2014 exam timetable yeah reviewing a ebook matriculant 2014 exam timetable could go to your close friends listings this is just one of the solutions for you to be successful as understood triumph does not recommend

the greatest instrument for promoting harmony and civilization - Jul 13 2023

web aug 1 2015 robert l bee this useful compilation of biographical sketches spans about 375 years of conflict the basic issue is native land rights versus unremitting colonial

9780853985914 the greatest instrument for promoting - Jul 01 2022

web abebooks com the greatest instrument for promoting harmony and civilization 9780853985914 and a great selection of similar new used and collectible books

iron nanoparticles open up new directions for promoting - Oct 24 2021

web 55 minutes ago metal nanoparticles play an outstanding role in the field of wound healing due to their excellent properties and the significance of iron one of the most widely used

the greatest instrument for promoting harmony and civilization - Mar 29 2022

web buy the greatest instrument for promoting harmony and civilization excerpts from the bahaa ai writings and related sources on the question of an international auxiliary

pdf publication flyer the greatest instrument for promoting - Jun 12 2023

web publication flyer the greatest instrument for promoting harmony and civilization gregory paul meyjes the baha i principle of an international auxiliary language ial

the greatest instrument for promoting harmony and pdf - Sep 22 2021

web mar 20 2023 the greatest instrument for promoting harmony and 2 5 downloaded from uniport edu ng on march 20 2023 by guest as closeness to the morpho syntactic

2023 state of the union address by president von der leyen - Aug 22 2021

web sep 13 2023 at the same time food security in harmony with nature remains an essential task i would like to take this opportunity to express my appreciation to our

the greatest instrument for promoting harmony and copy - Dec 26 2021

web the greatest instrument for promoting harmony and civilization gregory p meyjes 2015 the baha i principle of an international auxiliary language represents a novel

the greatest instrument for promoting harmony and civilization - Dec 06 2022

web jul 20 2015 the greatest instrument for promoting harmony and civilization meyjes gregory p 9780853985914 books amazon ca

the greatest instrument for promoting harmony and civilization - Apr 29 2022

web the greatest instrument for promoting harmony and civilization ebook meyjes gregory p amazon in kindle store

the greatest instrument for promoting harmony and civilization - Apr 10 2023

web select search scope currently catalog all catalog articles website more in one search catalog books media more in the

stanford libraries collections articles journal

[justculture consulting llc dealing justly with](#) - Jan 27 2022

web jun 27 2023 the greatest instrument for promoting harmony and civilization with an introduction that offers an extensive overview of the subject this publication contains a large selection of baha i writings read more zoom seminars

gregory paul meyjes 2023 07 13 race and race relations in baha i perspective

the greatest instrument for promoting harmony and civilization - Aug 02 2022

web jul 20 2015 buy the greatest instrument for promoting harmony and civilization excerpts from the bahaa ai writings and related sources on the question of an

gregory p meyjes the greatest instrument for promoting harmony and - Mar 09 2023

web the greatest instrument for promoting harmony and civilization author s leif nordenstorm source language problems and language planning volume 40 issue 1 jan 2016 p 100 102

for promoting harmony and civilization - Oct 04 2022

web greatest instrument for promoting harmony and civilization the greatest instrument for promoting harmony and civilization edited and introduced by gregory p meyjes specifications isbn 978 0 85398 591 4 136 pages soft cover 203 x 127 mm 8 x 5 ins 7 95 14 95

[gregory p meyjes the greatest instrument for promoting harmony and](#) - Jan 07 2023

web may 12 2016 the greatest instrument for promoting harmony and civilization find read and cite all the research you need on researchgate

the greatest instrument for promoting harmony and civilization - May 31 2022

web the greatest instrument for promoting harmony and civilization excerpts from the bahaa ai writings and related sources on the question of an international auxiliary language meyjes gregory p amazon sg books

buy the greatest instrument for promoting harmony and - Nov 24 2021

web amazon in buy the greatest instrument for promoting harmony and civilization excerpts from the bahaa ai writings and related sources on the question of an

[the greatest instrument for promoting harmony and civilization](#) - Feb 08 2023

web jul 20 2015 the greatest instrument for promoting harmony and civilization by jul 20 2015 george ronald publisher ltd edition the greatest instrument for promoting

the greatest instrument for promoting harmony and - Aug 14 2023

web jul 20 2015 this book provides quotations from the bahá í writings and related texts regarding the adoption of a common language chosen by the governments of the world

greatest instrument for promoting harmony and civilization - May 11 2023

web this book provides quotations from the bahá í writings and related texts regarding the adoption of a common language chosen by the governments of the world through their

the greatest instrument for promoting harmony and - Sep 03 2022

web jul 20 2015 buy the greatest instrument for promoting harmony and civilization by gregory p meyjes from waterstones today click and collect from your local

greatest instrument promoting harmony abebooks - Feb 25 2022

web the greatest instrument for promoting harmony and civilization and a great selection of related books art and collectibles available now at abebooks com

the greatest instrument for promoting harmony and civilization - Nov 05 2022

web the greatest instrument for promoting harmony and civilization excerpts from the bahaa ai writings and related sources on the question of an international auxiliary