

# CRANKCASE

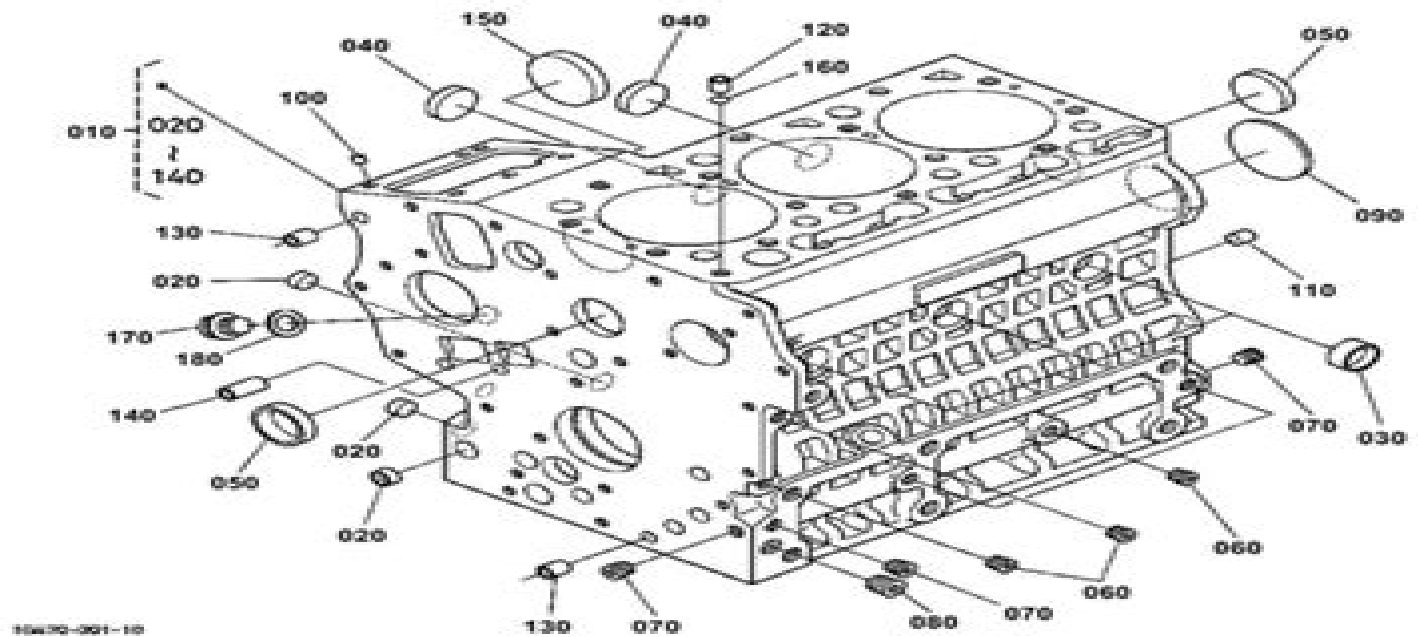

# Kubota Bx2230 Parts Manual

**Caterpillar Inc. Peoria, Ill..**



**Kubota Bx2230 Parts Manual:**

**Farmers and Consumers Market Bulletin** ,2011      **John Deere 520 Tractor Parts Manual** ,1966-02-15      *Service and Parts Manual; Carco Model E Winch* Pacific Car and Foundry Company (Renton, Wash.),Renton (Wash.),1950      *Master Parts Manual* Tecumseh Products Company. Engine and Gear Service Division,1982      **Parts Manual** Caterpillar Inc. Peoria, Ill.,1994      **Parts Manual** Caterpillar Inc. Peoria, Ill.,1993      *Parts Manual* Caterpillar Inc. Peoria, Ill.,1993      Parts Manual Caterpillar Inc. Peoria, Ill.,1995      **Parts Manual** Caterpillar Inc. Peoria, Ill.,1995      *Parts Manual* Caterpillar Inc. Peoria, Ill.,1996      Parts Manual Caterpillar Inc. Peoria, Ill.,1994      **Parts Manual** Caterpillar Inc. Peoria, Ill.,1992      **Parts Manual** Caterpillar Inc. Peoria, Ill.,1995      **Parts Manual** Caterpillar Inc. Peoria, Ill.,1996      Parts Manual Caterpillar Inc. Peoria, Ill.,1990      **Parts Manual** Caterpillar Inc. Peoria, Ill.,1992      **Parts Manual** Caterpillar Inc. Peoria, Ill.,1991      **Parts Manual** Caterpillar Inc. Peoria, Ill.,1993      **Parts Manual** Caterpillar Inc. Peoria, Ill.,1994      *Parts Manual* Caterpillar Inc. Peoria, Ill.,1992

Recognizing the showing off ways to get this books **Kubota Bx2230 Parts Manual** is additionally useful. You have remained in right site to start getting this info. acquire the Kubota Bx2230 Parts Manual member that we present here and check out the link.

You could purchase guide Kubota Bx2230 Parts Manual or acquire it as soon as feasible. You could speedily download this Kubota Bx2230 Parts Manual after getting deal. So, like you require the book swiftly, you can straight acquire it. Its in view of that no question easy and for that reason fats, isnt it? You have to favor to in this look

[http://www.armchairempire.com/results/book-search/Download\\_PDFS/Gsx%20750%20F%20Manual.pdf](http://www.armchairempire.com/results/book-search/Download_PDFS/Gsx%20750%20F%20Manual.pdf)

## **Table of Contents Kubota Bx2230 Parts Manual**

1. Understanding the eBook Kubota Bx2230 Parts Manual
  - The Rise of Digital Reading Kubota Bx2230 Parts Manual
  - Advantages of eBooks Over Traditional Books
2. Identifying Kubota Bx2230 Parts Manual
  - Exploring Different Genres
  - Considering Fiction vs. Non-Fiction
  - Determining Your Reading Goals
3. Choosing the Right eBook Platform
  - Popular eBook Platforms
  - Features to Look for in an Kubota Bx2230 Parts Manual
  - User-Friendly Interface
4. Exploring eBook Recommendations from Kubota Bx2230 Parts Manual
  - Personalized Recommendations
  - Kubota Bx2230 Parts Manual User Reviews and Ratings
  - Kubota Bx2230 Parts Manual and Bestseller Lists
5. Accessing Kubota Bx2230 Parts Manual Free and Paid eBooks

- Kubota Bx2230 Parts Manual Public Domain eBooks
  - Kubota Bx2230 Parts Manual eBook Subscription Services
  - Kubota Bx2230 Parts Manual Budget-Friendly Options
6. Navigating Kubota Bx2230 Parts Manual eBook Formats
    - ePub, PDF, MOBI, and More
    - Kubota Bx2230 Parts Manual Compatibility with Devices
    - Kubota Bx2230 Parts Manual Enhanced eBook Features
  7. Enhancing Your Reading Experience
    - Adjustable Fonts and Text Sizes of Kubota Bx2230 Parts Manual
    - Highlighting and Note-Taking Kubota Bx2230 Parts Manual
    - Interactive Elements Kubota Bx2230 Parts Manual
  8. Staying Engaged with Kubota Bx2230 Parts Manual
    - Joining Online Reading Communities
    - Participating in Virtual Book Clubs
    - Following Authors and Publishers Kubota Bx2230 Parts Manual
  9. Balancing eBooks and Physical Books Kubota Bx2230 Parts Manual
    - Benefits of a Digital Library
    - Creating a Diverse Reading Collection Kubota Bx2230 Parts Manual
  10. Overcoming Reading Challenges
    - Dealing with Digital Eye Strain
    - Minimizing Distractions
    - Managing Screen Time
  11. Cultivating a Reading Routine Kubota Bx2230 Parts Manual
    - Setting Reading Goals Kubota Bx2230 Parts Manual
    - Carving Out Dedicated Reading Time
  12. Sourcing Reliable Information of Kubota Bx2230 Parts Manual
    - Fact-Checking eBook Content of Kubota Bx2230 Parts Manual
    - Distinguishing Credible Sources
  13. Promoting Lifelong Learning
    - Utilizing eBooks for Skill Development

- Exploring Educational eBooks
- 14. Embracing eBook Trends
  - Integration of Multimedia Elements
  - Interactive and Gamified eBooks

### **Kubota Bx2230 Parts Manual Introduction**

In today's digital age, the availability of Kubota Bx2230 Parts Manual books and manuals for download has revolutionized the way we access information. Gone are the days of physically flipping through pages and carrying heavy textbooks or manuals. With just a few clicks, we can now access a wealth of knowledge from the comfort of our own homes or on the go. This article will explore the advantages of Kubota Bx2230 Parts Manual books and manuals for download, along with some popular platforms that offer these resources. One of the significant advantages of Kubota Bx2230 Parts Manual books and manuals for download is the cost-saving aspect. Traditional books and manuals can be costly, especially if you need to purchase several of them for educational or professional purposes. By accessing Kubota Bx2230 Parts Manual versions, you eliminate the need to spend money on physical copies. This not only saves you money but also reduces the environmental impact associated with book production and transportation. Furthermore, Kubota Bx2230 Parts Manual books and manuals for download are incredibly convenient. With just a computer or smartphone and an internet connection, you can access a vast library of resources on any subject imaginable. Whether you're a student looking for textbooks, a professional seeking industry-specific manuals, or someone interested in self-improvement, these digital resources provide an efficient and accessible means of acquiring knowledge. Moreover, PDF books and manuals offer a range of benefits compared to other digital formats. PDF files are designed to retain their formatting regardless of the device used to open them. This ensures that the content appears exactly as intended by the author, with no loss of formatting or missing graphics. Additionally, PDF files can be easily annotated, bookmarked, and searched for specific terms, making them highly practical for studying or referencing. When it comes to accessing Kubota Bx2230 Parts Manual books and manuals, several platforms offer an extensive collection of resources. One such platform is Project Gutenberg, a nonprofit organization that provides over 60,000 free eBooks. These books are primarily in the public domain, meaning they can be freely distributed and downloaded. Project Gutenberg offers a wide range of classic literature, making it an excellent resource for literature enthusiasts. Another popular platform for Kubota Bx2230 Parts Manual books and manuals is Open Library. Open Library is an initiative of the Internet Archive, a non-profit organization dedicated to digitizing cultural artifacts and making them accessible to the public. Open Library hosts millions of books, including both public domain works and contemporary titles. It also allows users to borrow digital copies of certain books for a limited period, similar to a library lending system. Additionally, many universities

and educational institutions have their own digital libraries that provide free access to PDF books and manuals. These libraries often offer academic texts, research papers, and technical manuals, making them invaluable resources for students and researchers. Some notable examples include MIT OpenCourseWare, which offers free access to course materials from the Massachusetts Institute of Technology, and the Digital Public Library of America, which provides a vast collection of digitized books and historical documents. In conclusion, Kubota Bx2230 Parts Manual books and manuals for download have transformed the way we access information. They provide a cost-effective and convenient means of acquiring knowledge, offering the ability to access a vast library of resources at our fingertips. With platforms like Project Gutenberg, Open Library, and various digital libraries offered by educational institutions, we have access to an ever-expanding collection of books and manuals. Whether for educational, professional, or personal purposes, these digital resources serve as valuable tools for continuous learning and self-improvement. So why not take advantage of the vast world of Kubota Bx2230 Parts Manual books and manuals for download and embark on your journey of knowledge?

### **FAQs About Kubota Bx2230 Parts Manual Books**

**What is a Kubota Bx2230 Parts Manual PDF?** A PDF (Portable Document Format) is a file format developed by Adobe that preserves the layout and formatting of a document, regardless of the software, hardware, or operating system used to view or print it. **How do I create a Kubota Bx2230 Parts Manual PDF?** There are several ways to create a PDF: Use software like Adobe Acrobat, Microsoft Word, or Google Docs, which often have built-in PDF creation tools. **Print to PDF:** Many applications and operating systems have a "Print to PDF" option that allows you to save a document as a PDF file instead of printing it on paper. **Online converters:** There are various online tools that can convert different file types to PDF. **How do I edit a Kubota Bx2230 Parts Manual PDF?** Editing a PDF can be done with software like Adobe Acrobat, which allows direct editing of text, images, and other elements within the PDF. Some free tools, like PDFescape or Smallpdf, also offer basic editing capabilities. **How do I convert a Kubota Bx2230 Parts Manual PDF to another file format?** There are multiple ways to convert a PDF to another format: Use online converters like Smallpdf, Zamzar, or Adobe Acrobat's export feature to convert PDFs to formats like Word, Excel, JPEG, etc. Software like Adobe Acrobat, Microsoft Word, or other PDF editors may have options to export or save PDFs in different formats. **How do I password-protect a Kubota Bx2230 Parts Manual PDF?** Most PDF editing software allows you to add password protection. In Adobe Acrobat, for instance, you can go to "File" -> "Properties" -> "Security" to set a password to restrict access or editing capabilities. Are there any free alternatives to Adobe Acrobat for working with PDFs? Yes, there are many free alternatives for working with PDFs, such as: LibreOffice: Offers PDF editing features. PDFsam: Allows splitting, merging, and editing PDFs. Foxit Reader: Provides basic

PDF viewing and editing capabilities. How do I compress a PDF file? You can use online tools like Smallpdf, ILovePDF, or desktop software like Adobe Acrobat to compress PDF files without significant quality loss. Compression reduces the file size, making it easier to share and download. Can I fill out forms in a PDF file? Yes, most PDF viewers/editors like Adobe Acrobat, Preview (on Mac), or various online tools allow you to fill out forms in PDF files by selecting text fields and entering information. Are there any restrictions when working with PDFs? Some PDFs might have restrictions set by their creator, such as password protection, editing restrictions, or print restrictions. Breaking these restrictions might require specific software or tools, which may or may not be legal depending on the circumstances and local laws.

### **Find Kubota Bx2230 Parts Manual :**

*gsx 750 f manual*

*growing a business paul hawken*

**grundlagen mathematik einfach klar verst ndlich ebook**

*grillon du foyer french*

**gsg pk5 full auto conversion manual**

*grijsboek of de nagelaten bekentenissen van raoul chapkis*

**guardians of the galaxyall new x men the trial of jean grey**

grocery department training manual

**guardians of gahoole the rise of a legend**

growing up nascar racings most outrageous promoter tells all

**grenzverschiebungen sexuellen perspektiven jungen sexualwissenschaft**

~~guia de los fundamentos de la direccion de proyectos pmbok 4ta edicion~~

**griffin and sabine an extraordinary correspondence**

grubers gre strategies practice and review 2015 2016

*grl2grl short fictions*

### **Kubota Bx2230 Parts Manual :**

German Vocabulary for English Speakers - 7000 words ... This book is intended to help you learn, memorize, and review over 7000 commonly used German words. Recommended as additional support material to any language ... German vocabulary for English speakers - 7000 words T&P BOOKS VOCABULARIES are intended to help you learn, memorize and review foreign



words. This bilingual dictionary contains over 7000 commonly used words ... German vocabulary for English speakers - 7000 words 7000-WORD ENGLISH-GERMAN VOCABULARY. The knowledge of approximately 7000 words makes it possible to understand authentic German texts. German vocabulary for English speakers - 7000 words ... 7000-WORD ENGLISH-GERMAN VOCABULARY. The knowledge of approximately 7000 words makes it possible to understand authentic German texts. German Vocabulary for English Speakers Cover for "German vocabulary for English speakers - 7000 words". German vocabulary for English speakers - 7000 words Buy the book German vocabulary for English speakers - 7000 words by andrey taranov at Indigo. German vocabulary for English speakers - 7000 words | Libristo - EU Looking for German vocabulary for English speakers - 7000 words by: Andrey Taranov? Shop at a trusted shop at affordable prices. 30-day return policy! German vocabulary for English speakers - 7000 words German vocabulary for English speakers - 7000 words - American English Collection 127 (Paperback) ; Publisher: T&p Books ; ISBN: 9781780713144 ; Weight: 209 g German vocabulary for English speakers - 5000 words ... Aug 1, 2012 — German vocabulary for English speakers - 5000 words (Paperback) ... Our German collection includes also vocabularies of 3000, 7000 and 9000 words. German vocabulary for English speakers - 7000 words German vocabulary for English speakers - 7000 words · Allgemein, unspezialisiert · Wörterbücher · Lexika · Nachschlagewerke · Fremdsprachige Wörterbücher. Audi 100 A6 Official Factory Repair Manual ... Feb 7, 1997 — Search - Audi 100, A6 : Official Factory Repair Manual 1992-1997:Including S4, S6, Quattro and Wagon Models (3 volume set) ; Pages: 3,854 Audi 100, A6 : Repair Manual 1992-1997: ... Audi 100, A6 : Repair Manual 1992-1997:Including S4, S6, Quattro and Wagon Models (3 volume set) by Audi Of America - ISBN 10: 0837603749 - ISBN 13: ... Audi Repair Manual: 100, A6: 1992-1997 Softcover, 8 3/8 in. x 11 in. Three volume set totaling 3,854 pages 3,236 illustrations and diagrams 1,228 electrical wiring diagrams. Audi Part No. LPV 800 702 Audi 100, A6 : Repair Manual 1992-1997:Including S4, S6 ... Dec 31, 1996 — Every manual is complete with all factory specifications and tolerances. Show more. 3854 pages ... 1992-1997 Audi 100 A6 S4 S6 Quattro Service ... 1992-1997 Audi 100 A6 S4 S6 Quattro Service Repair Manual 1993 1994 1995 1996 ; Quantity. 1 available ; Item Number. 374788484717 ; Accurate description. 4.8. Get the Best Priced Audi A6 Quattro Repair Manual The Audi A6 Quattro Repair Manual can help lower repair costs by teaching you how to fix a vehicle without an expert. Audi A6 (C5) Service Manual: 1998, 1999 Audi 100, A6 : Official Factory Repair Manual 1992-1997:Including S4, S6, Quattro and Wagon Models (3 volume set). Audi of America. Out of Stock. 1992-1997 Audi 100 S4 A6 S6 2.8L V6 Service ... 1992-1997 Audi 100 S4 A6 S6 2.8L V6 Service Repair Manual 1993 1994 1995 1996 ; Quantity. 1 available ; Item Number. 253308373969 ; Accurate description. 4.8. Download - Bentley Publishers Jan 12, 2015 — Turn your PDF publications into a flip-book with our unique Google optimized e-Paper software. ... Manual: 1997-2002. An M62 eight cylinder engine ... Sample Test Items - Kentucky Department of Education Nov 27, 2023 — Kentucky periodically releases test and sample items coordinated with the state assessments to help students and teachers become more familiar ... Released Items - KY These

items may be used to help familiarize test examiners and students with the assessment and item format. Released Items. 2023 Released Items. Reading. Kentucky Summative Assessment Sep 29, 2023 — KSA are the annual summative assessments given in grades 3 through 8, 10 and 11 to Kentucky public school students. KSA provides content area ... Practice Tests - KY Practice Tests and Content Based Answer Keys/Rubrics Access resources for educators to prepare students for testing. Free KSA Practice Test & Sample Questions Take the free online KSA practice test. Assess your student's Kentucky State test readiness in 5 minutes. Grade 3 - 8 for Math & English (ELA). Try Now! Support Materials for Core Content for Assessment Reading Students must be able to support their thinking. Items may involve abstract theme identification, inference across an entire passage, or students' application ... Kentucky Reading Academies powered by LETRS The KY DOE is offering a statewide professional learning opportunity for K-5 educators with evidence-based practices for reading instruction through LETRS ... KY KSA Practice Test - Edulastic Online assessment tools with technology-enhanced items like SBAC, AIR and PARCC give you a complete, instant view of student learning and growth. K-PREP Practice Test Kentucky | Core Academic Standards. Education Galaxy's K-PREP online practice tests provides online assessment and practice for students in Grades K-5. Sign up for FREE. JCPS Social Studies - State Assessment KSA Items includes released test questions and test stats. The test stats show a key, aligned standards, percentages, and a demographic breakdown for the state.