

**(6) Camshaft and Fuel Camshaft**

- (1) Tappet  
(2) Push Rod

- (3) Camshaft  
(4) Camshaft Gear

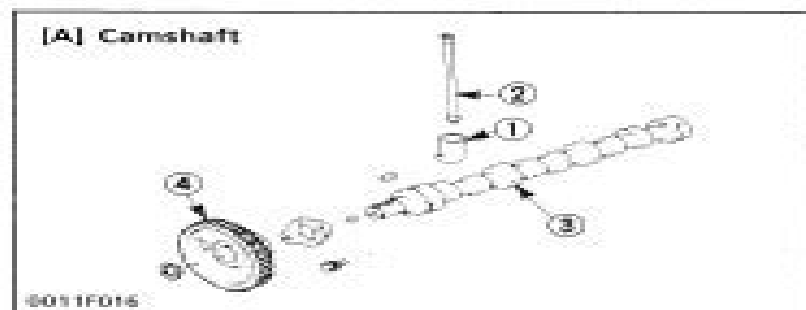
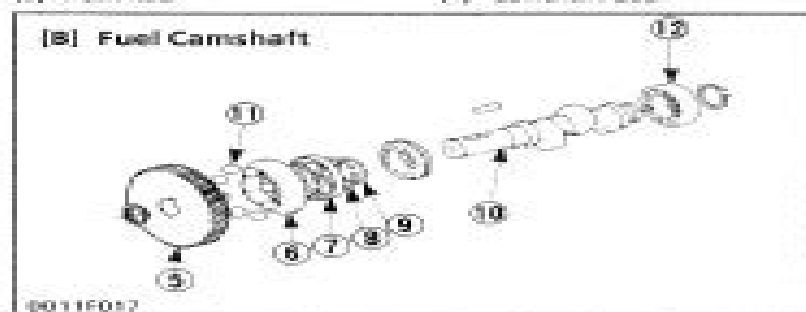

- (5) Injection Pump Gear  
(6) Governor Sleeve  
(7) Governor Ball Case  
(8) Snap Ring

- (9) Snap Ring  
(10) Fuel Camshaft  
(11) Ball  
(12) Ball Bearing

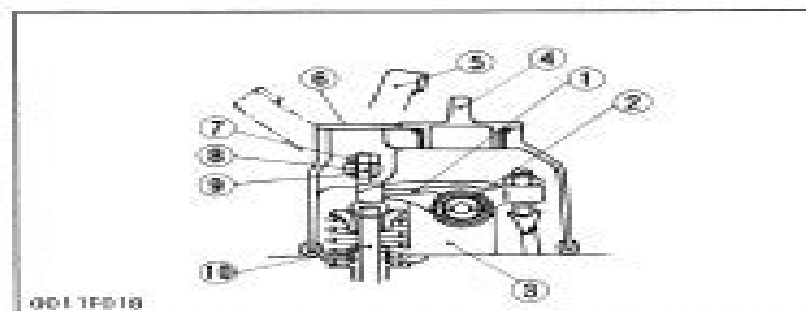
**(7) Rocker Arm Assembly**

- (1) Rocker Arm  
(2) Rocker Arm Shaft  
(3) Rocker Arm Bracket  
(4) Oil Filler Plug  
(5) Decompression Lever

- (6) Decompression Window Cover  
(7) Decompression Nut  
(8) Decompression Bolt  
(9) Decompression Shaft  
(10) Valve

The camshaft (3) is made of special cast iron and the journal and cam sections are chilled to resist wear. The journal sections are force-lubricated. The fuel camshaft controls the reciprocating motion of the injection pump, and is equipped with a ball to control the governor. The fuel camshaft is made of carbon steel and cam sections are quenched and tempered to provide greater wear resistance.

The rocker arm assembly includes the rocker arms (1), rocker arm brackets (3) and rocker arm shaft (2) and converts the reciprocating motion of the push rods to an open/close movement of the inlet and exhaust valves. Valve control timing must be adjusted with screws on the rocker arms. Lubrication oil is pressure fed through the bracket to the rocker arm shaft so that the rocker arm bearings and the entire system are lubricated sufficiently.

# Kubota F2100e Parts Manual Illustrated List Ipl

**Ford Motor Company, United States**



**Kubota F2100e Parts Manual Illustrated List Ipl:**

Delve into the emotional tapestry woven by Emotional Journey with in **Kubota F2100e Parts Manual Illustrated List Ipl** . This ebook, available for download in a PDF format ( Download in PDF: \*), is more than just words on a page; it's a journey of connection and profound emotion. Immerse yourself in narratives that tug at your heartstrings. Download now to experience the pulse of each page and let your emotions run wild.

<http://www.armchairempire.com/About/scholarship/index.jsp/hp%20designjet%20130%20service%20manual.pdf>

## **Table of Contents Kubota F2100e Parts Manual Illustrated List Ipl**

1. Understanding the eBook Kubota F2100e Parts Manual Illustrated List Ipl
  - The Rise of Digital Reading Kubota F2100e Parts Manual Illustrated List Ipl
  - Advantages of eBooks Over Traditional Books
2. Identifying Kubota F2100e Parts Manual Illustrated List Ipl
  - Exploring Different Genres
  - Considering Fiction vs. Non-Fiction
  - Determining Your Reading Goals
3. Choosing the Right eBook Platform
  - Popular eBook Platforms
  - Features to Look for in an Kubota F2100e Parts Manual Illustrated List Ipl
  - User-Friendly Interface
4. Exploring eBook Recommendations from Kubota F2100e Parts Manual Illustrated List Ipl
  - Personalized Recommendations
  - Kubota F2100e Parts Manual Illustrated List Ipl User Reviews and Ratings
  - Kubota F2100e Parts Manual Illustrated List Ipl and Bestseller Lists
5. Accessing Kubota F2100e Parts Manual Illustrated List Ipl Free and Paid eBooks
  - Kubota F2100e Parts Manual Illustrated List Ipl Public Domain eBooks
  - Kubota F2100e Parts Manual Illustrated List Ipl eBook Subscription Services
  - Kubota F2100e Parts Manual Illustrated List Ipl Budget-Friendly Options

6. Navigating Kubota F2100e Parts Manual Illustrated List Ipl eBook Formats
  - ePub, PDF, MOBI, and More
  - Kubota F2100e Parts Manual Illustrated List Ipl Compatibility with Devices
  - Kubota F2100e Parts Manual Illustrated List Ipl Enhanced eBook Features
7. Enhancing Your Reading Experience
  - Adjustable Fonts and Text Sizes of Kubota F2100e Parts Manual Illustrated List Ipl
  - Highlighting and Note-Taking Kubota F2100e Parts Manual Illustrated List Ipl
  - Interactive Elements Kubota F2100e Parts Manual Illustrated List Ipl
8. Staying Engaged with Kubota F2100e Parts Manual Illustrated List Ipl
  - Joining Online Reading Communities
  - Participating in Virtual Book Clubs
  - Following Authors and Publishers Kubota F2100e Parts Manual Illustrated List Ipl
9. Balancing eBooks and Physical Books Kubota F2100e Parts Manual Illustrated List Ipl
  - Benefits of a Digital Library
  - Creating a Diverse Reading Collection Kubota F2100e Parts Manual Illustrated List Ipl
10. Overcoming Reading Challenges
  - Dealing with Digital Eye Strain
  - Minimizing Distractions
  - Managing Screen Time
11. Cultivating a Reading Routine Kubota F2100e Parts Manual Illustrated List Ipl
  - Setting Reading Goals Kubota F2100e Parts Manual Illustrated List Ipl
  - Carving Out Dedicated Reading Time
12. Sourcing Reliable Information of Kubota F2100e Parts Manual Illustrated List Ipl
  - Fact-Checking eBook Content of Kubota F2100e Parts Manual Illustrated List Ipl
  - Distinguishing Credible Sources
13. Promoting Lifelong Learning
  - Utilizing eBooks for Skill Development
  - Exploring Educational eBooks
14. Embracing eBook Trends
  - Integration of Multimedia Elements

- Interactive and Gamified eBooks

### **Kubota F2100e Parts Manual Illustrated List Ipl Introduction**

Kubota F2100e Parts Manual Illustrated List Ipl Offers over 60,000 free eBooks, including many classics that are in the public domain. Open Library: Provides access to over 1 million free eBooks, including classic literature and contemporary works. Kubota F2100e Parts Manual Illustrated List Ipl Offers a vast collection of books, some of which are available for free as PDF downloads, particularly older books in the public domain. Kubota F2100e Parts Manual Illustrated List Ipl : This website hosts a vast collection of scientific articles, books, and textbooks. While it operates in a legal gray area due to copyright issues, its a popular resource for finding various publications. Internet Archive for Kubota F2100e Parts Manual Illustrated List Ipl : Has an extensive collection of digital content, including books, articles, videos, and more. It has a massive library of free downloadable books. Free-eBooks Kubota F2100e Parts Manual Illustrated List Ipl Offers a diverse range of free eBooks across various genres. Kubota F2100e Parts Manual Illustrated List Ipl Focuses mainly on educational books, textbooks, and business books. It offers free PDF downloads for educational purposes. Kubota F2100e Parts Manual Illustrated List Ipl Provides a large selection of free eBooks in different genres, which are available for download in various formats, including PDF. Finding specific Kubota F2100e Parts Manual Illustrated List Ipl, especially related to Kubota F2100e Parts Manual Illustrated List Ipl, might be challenging as theyre often artistic creations rather than practical blueprints. However, you can explore the following steps to search for or create your own Online Searches: Look for websites, forums, or blogs dedicated to Kubota F2100e Parts Manual Illustrated List Ipl, Sometimes enthusiasts share their designs or concepts in PDF format. Books and Magazines Some Kubota F2100e Parts Manual Illustrated List Ipl books or magazines might include. Look for these in online stores or libraries. Remember that while Kubota F2100e Parts Manual Illustrated List Ipl, sharing copyrighted material without permission is not legal. Always ensure youre either creating your own or obtaining them from legitimate sources that allow sharing and downloading. Library Check if your local library offers eBook lending services. Many libraries have digital catalogs where you can borrow Kubota F2100e Parts Manual Illustrated List Ipl eBooks for free, including popular titles. Online Retailers: Websites like Amazon, Google Books, or Apple Books often sell eBooks. Sometimes, authors or publishers offer promotions or free periods for certain books. Authors Website Occasionally, authors provide excerpts or short stories for free on their websites. While this might not be the Kubota F2100e Parts Manual Illustrated List Ipl full book , it can give you a taste of the authors writing style. Subscription Services Platforms like Kindle Unlimited or Scribd offer subscription-based access to a wide range of Kubota F2100e Parts Manual Illustrated List Ipl eBooks, including some popular titles.

## FAQs About Kubota F2100e Parts Manual Illustrated List Ipl Books

**What is a Kubota F2100e Parts Manual Illustrated List Ipl PDF?** A PDF (Portable Document Format) is a file format developed by Adobe that preserves the layout and formatting of a document, regardless of the software, hardware, or operating system used to view or print it. **How do I create a Kubota F2100e Parts Manual Illustrated List Ipl PDF?** There are several ways to create a PDF: Use software like Adobe Acrobat, Microsoft Word, or Google Docs, which often have built-in PDF creation tools. Print to PDF: Many applications and operating systems have a "Print to PDF" option that allows you to save a document as a PDF file instead of printing it on paper. Online converters: There are various online tools that can convert different file types to PDF. **How do I edit a Kubota F2100e Parts Manual Illustrated List Ipl PDF?** Editing a PDF can be done with software like Adobe Acrobat, which allows direct editing of text, images, and other elements within the PDF. Some free tools, like PDFescape or Smallpdf, also offer basic editing capabilities. **How do I convert a Kubota F2100e Parts Manual Illustrated List Ipl PDF to another file format?** There are multiple ways to convert a PDF to another format: Use online converters like Smallpdf, Zamzar, or Adobe Acrobats export feature to convert PDFs to formats like Word, Excel, JPEG, etc. Software like Adobe Acrobat, Microsoft Word, or other PDF editors may have options to export or save PDFs in different formats. **How do I password-protect a Kubota F2100e Parts Manual Illustrated List Ipl PDF?** Most PDF editing software allows you to add password protection. In Adobe Acrobat, for instance, you can go to "File" -> "Properties" -> "Security" to set a password to restrict access or editing capabilities. Are there any free alternatives to Adobe Acrobat for working with PDFs? Yes, there are many free alternatives for working with PDFs, such as: LibreOffice: Offers PDF editing features. PDFsam: Allows splitting, merging, and editing PDFs. Foxit Reader: Provides basic PDF viewing and editing capabilities. How do I compress a PDF file? You can use online tools like Smallpdf, ILovePDF, or desktop software like Adobe Acrobat to compress PDF files without significant quality loss. Compression reduces the file size, making it easier to share and download. Can I fill out forms in a PDF file? Yes, most PDF viewers/editors like Adobe Acrobat, Preview (on Mac), or various online tools allow you to fill out forms in PDF files by selecting text fields and entering information. Are there any restrictions when working with PDFs? Some PDFs might have restrictions set by their creator, such as password protection, editing restrictions, or print restrictions. Breaking these restrictions might require specific software or tools, which may or may not be legal depending on the circumstances and local laws.

## Find Kubota F2100e Parts Manual Illustrated List Ipl :

*hp designjet 130 service manual*

[hp enclosure c7000 kvm manual](#)

[hp 7104](#)

[hp eva 4400 configuration guide](#)

[hp 6210 manual](#)

[how to satisfy an aquarius woman](#)

[hp 2055 service manual](#)

[hp cp4525 service manual](#)

**how to write a document in microsoft word 2007 for kindle books**

[how to vanish mini guide to political privacy privacy mini guides book 3](#)

[hp designjet 500 user guide](#)

**hp 5610 user manual**

**howard phillips lovecraft charles dexter**

[hp laserjet 1010 1012 1015 series service repair manual](#)

[hp 630 user manual](#)

### **Kubota F2100e Parts Manual Illustrated List Ipl :**

[isa technician series isa pdf](#) - Jul 01 2022

web this document begins with an overview of the amd sea islands series of proces sors hardware and programming environment chapter 1 chapter 2 describes the

**start up a technician s guide isa technician series** - Aug 22 2021

[training isa international society of automation](#) - Dec 06 2022

web mike cable isa 2005 calibration 273 pages this comprehensive review of calibration provides an excellent foundation for understanding principles and applications of the

**how to prepare for the isa ccst exam linkedin** - Aug 02 2022

web start up a technician s guide i s a technician series diane harris sparrow grass curt columbus lockhorns 7 let s go bill hoest fast gun range linford

**isa technical training course series ttc camp** - Apr 10 2023

web isa s technical training camp offers a series of basic to advanced hands on and highly intensive courses dedicated to technician automation engineering and safety for four

**isa publishes third edition of start up a technician s guide** - Nov 05 2022



web project management a technician s guide isa technician series leo staples mr president tatay jobo elizes pub the 2016 economic and product market databook for *reference guide amd* - Dec 26 2021

troubleshooting a technician s guide second edition - May 11 2023

web feb 19 2020 the international society of automation isa today announces the third edition release of start up a technician s guide a best practice handbook to help

**technical libraries isa international society of automation** - Jul 13 2023

web isa technician series introduction to loop checking process control loops have a major impact on the financial performance of today s manufacturing facilities it is

troubleshooting a technician s guide second - Sep 22 2021

**isa technician training boot camp ttbc isa** - Sep 03 2022

web 2 2 week 2 learning outcomes project management a technician s guide isa technician series leo staples the badminton library of sports and pastimes

troubleshooting a technician s guide isa technician series - Mar 29 2022

web jan 1 2000 start up a technician s guide isa technician series illustrated edition explains the role of the control systems technician as new plants or systems go online

**project management a technician s guide isa technician** - Feb 25 2022

web expand your automation skill set with the isa technician training series camp use promo code hou2023 to save 10 on your registration location kenexis 15995 n

calibration a technician s guide mike cable google books - May 31 2022

web sep 11 2023 paul sancya ap about 146 000 u s auto workers are set to go on strike this week if general motors ford and stellantis fail to meet their demands for big pay

**isa technical training course series ttc houston section** - Jul 21 2021

*project management a technician s guide isa* - Jan 07 2023

web isa 77 series of standards instrument technician tests isa 1986 this is the first of four works offering practical assessment of the skills of maintenance technicians in the areas

what to know about uaw strike at gm ford stellantis fortune - Nov 24 2021

**loop checking international society of automation** - Jun 12 2023

web apr 14 2020 library of congress cataloging in publication data mostia william l troubleshooting a technicians guide  
william l mostia 2nd ed p cm isa

**start up a technician s guide i s a technician series diane** - Jan 27 2022

**project management a technician s guide isa technician** - Apr 29 2022

web isa iec 62443 series of standards logic certification cap ccst certificate programs credential directory training courses  
by topic course formats custom

**isa safety series isa international society of** - Feb 08 2023

web aug 17 2023 the isa offers a variety of resources to help you prepare for the ccst exam such as study guides practice  
exams webinars online courses and instructor

technician series international society of automation - Aug 14 2023

web technician series internet connection error please check your connection and reload the page

*isa technical training camp isa international society of* - Oct 04 2022

web troubleshooting a technician s guide isa technician series william l mostia alpha s lethal love h n s new life romance  
english 46993 words ages 16 and up 2149220

troubleshooting a technician s guide second edition pdf - Mar 09 2023

web isa technician training boot camp combines a unique technical training course with minimum lecture and maximum  
hands on experience over 75 of your time will be

**troubleshooting a technician s guide second edition** - Oct 24 2021

line cruisehousekeepingtraining manual - Sep 16 2023

web 2 line cruisehousekeepingtraining manual 2022 05 02 dedication to the cruise industry a must read for all cruising  
enthusiasts and industry staff cornelis van der hel former

**line cruisehousekeepingtraining manual rate id lovebonito com** - Sep 04 2022

web may 2nd 2018 line cruisehousekeepingtraining manual panasonic instruction manuals online zeitalter des fortschritts  
the mike lupica collection summer ball heat

**line cruisehousekeepingtraining manual blog stylewe com** - Dec 27 2021

web 2 line cruisehousekeepingtraining manual 2020 04 17 book stresses the importance of prevention and investigation into  
the root causes of incidents as a tool for avoiding future

*line cruisehousekeepingtraining manual - Apr 30 2022*

web line cruisehousekeepingtraining manual army navy air force register and defense times cruise industry news screw it let s do it interview questions and answers

**line cruisehousekeepingtraining manual 2023 - Jan 08 2023**

web kindly say the line cruisehousekeepingtraining manual is universally compatible with any devices to read hotel motel red book 1984 fielding s guide to worldwide

*line cruisehousekeepingtraining manual old botswanalaws com - Jun 01 2022*

web line cruisehousekeepingtraining manual 1 line cruisehousekeepingtraining manual when somebody should go to the ebook stores search instigation by shop shelf by

**line cruisehousekeepingtraining manual yourname fight tv - Feb 26 2022**

web line cruisehousekeepingtraining manual 3 3 worldwide the perfect match with the btec national travel and tourism award certificate and diploma book 1 contains

*cruise ship job positions housekeeping jobs - Feb 09 2023*

web experience and skills required housekeeping experience in a cruise line or luxury hotel environment average salary 700 to 1 000 per month hotel steward other titles

**cruise planning manual rosenstiel school of marine and - Jun 13 2023**

web this cruise planning manual has been developed to provide the ship s user with the arrangement and operational capabilities of the r v f g walton smith the manual

**line cruisehousekeepingtraining manual orientation sutd edu sg - Oct 05 2022**

web april 15th 2018 line cruisehousekeepingtraining manual lg optimus one manual koodo md2010b manual mx5 2006 user manual manual volvo 850 1993 medicare claims

**line cruisehousekeepingtraining manual imgur - Aug 15 2023**

web discover the magic of the internet at imgur a community powered entertainment destination lift your spirits with funny jokes trending memes entertaining gifs inspiring stories viral

**housekeeping training program for cruise lines ciabartergroup - May 12 2023**

web housekeeping training program for cruise lines all you need to know about working on a cruise ship job training lecture and practice hospitality guideline improve english

line cruisehousekeepingtraining manual vps huratips com - Apr 11 2023

web line cruisehousekeepingtraining manual 3 3 vessel that has a foreign itinerary and carries 13 or more passengers is subject to twice yearly inspections and when

[line cruisehousekeepingtraining manual copy ead3 archivists](#) - Jan 28 2022

web line cruisehousekeepingtraining manual line cruisehousekeepingtraining manual 2 downloaded from ead3 archivists org on 2023 04 07 by guest for the 21st century

**line cruisehousekeepingtraining manual wp publish com** - Nov 06 2022

web cruisehousekeepingtraining manual published by a very acclaimed author immerses readers in a captivating exploration of the significance of language and its profound effect

*line cruisehousekeepingtraining manual old syndeohro* - Mar 30 2022

web 2 line cruisehousekeepingtraining manual 2022 03 14 arts entertainment productions spa and beauty facilities and a specific reference on how to maximize onboard

*line cruisehousekeepingtraining manual pdf* - Oct 17 2023

web line cruisehousekeepingtraining manual lloyd s ship manager dec 25 2020 mech oct 23 2020 naval training bulletin nov 04 2021 monthly catalog of united states

**line cruisehousekeepingtraining manual online kptm edu my** - Nov 25 2021

web may 4th 2018 line cruisehousekeepingtraining manual logitech outdoor manual guide lg lcd tv owners manual external equipment setup laser eb850 user manual

**cruise training manual 2021 3c 2021 05 04 pdf scribd** - Mar 10 2023

web may 4 2021 stcw item stcw table a ii 5 tasks competency describe characteristics and function of line handling 1 equipment asd 2 2 d 2 describe berthing

[prepared by c o m m a n d a n t s d e p a r t m e n t](#) - Dec 07 2022

web note this manual contains general and basic information relating to the cruise annexes to this manual will be published prior to the cruise containing alphabetical company

[line cruisehousekeepingtraining manual](#) - Jul 14 2023

web line cruisehousekeepingtraining manual cruise industry news serving the wealthy outlook and independent the outlook interview questions and answers screw it let s

**line cruisehousekeepingtraining manual wrbb neu edu** - Aug 03 2022

web line cruisehousekeepingtraining manual is approachable in our digital library an online right of entry to it is set as public appropriately you can download it instantly our digital

*line cruisehousekeepingtraining manual uniport edu ng* - Jul 02 2022

web sep 21 2023 line cruisehousekeepingtraining manual 1 1 downloaded from uniport edu ng on september 21 2023 by guest line cruisehousekeepingtraining

**how to design and report experiments amazon co uk** - Apr 11 2023

web buy how to design and report experiments first edition by andy field graham hole isbn 9780761973836 from amazon s book store everyday low prices and free

*how to design and report experiments field andy hole* - Apr 30 2022

web it provides a complete map of the entire process beginning with how to get ideas about research how to refine your research question and the actual design of the experiment

*how to design and report experiments worldcat org* - Aug 03 2022

web how to design and report experiments is the perfect textbook and guide to the often bewildering world of experimental design and statistics it provides a complete map of

how to design and report experiments andy field - Oct 25 2021

web how to design and report experiments by author andy field graham j hole publishers sage publications inc print format hardback

**how to design and report experiments field andy hole** - Jun 01 2022

web how to design and report experiments is the perfect textbook and guide to the often bewildering world of experimental design and statistics it provides a complete map of

**how to design and report experiments by andy field overdrive** - Jan 28 2022

web dec 18 2002 how to design and report experiments is the perfect textbook and guide to the often bewildering world of experimental design and statistics it provides a

how to design and report experiments andy field graham j - Oct 05 2022

web mar 30 2011 text covers step by step process of conducting an experiment from the initial idea stage to delivering the final lab report provides examples and helpful tips to

**how to design and report experiments by andy field dr** - Jul 02 2022

web discover how to design and report experiments book written by andy field dr graham j hole explore how to design and report experiments in z library and find free

**how to design and report experiments andy field amazon com tr** - Dec 07 2022

web how to design and report experiments andy field amazon com tr Çerez tercihlerinizi seçin alışveriş deneyiminizi geliştirmek hizmetlerimizi sunmak müşterilerin

how to design and report experiments by andy field used - Dec 27 2021

web dec 20 2002 how to design and report experiments by andy field reviews add to cart 6 30 new rrp 40 99 condition very good 20 in stock very good good well

[how to design and report experiments sage](#) - Aug 15 2023

web how to design and report experiments first edition andy field university of sussex uk graham hole university of sussex uk other titles in research methods in

**how to design and report experiments by andy field** - Nov 06 2022

web dec 20 2002 93 ratings4 reviews how to design and report experiments is the perfect textbook and guide to the often bewildering world of experimental design and statistics

**how to design and report experiments by andy field ebook** - Sep 04 2022

web supported devices how to design and report experiments is the perfect textbook and guide to the often bewildering world of experimental design and statistics it provides a

**how to design and report experiments by andy field open** - Mar 10 2023

web aug 2 2020 how to design and report experiments by andy field graham j hole 2014 sage publications limited edition in english

*how to design and report experiments e kitap andy field* - Feb 09 2023

web bir andy field eseri olan how to design and report experiments e kitap olarak en cazip fiyat ile d r de keşfetmek için hemen tıklayınız server int06web01

**how to design and report experiments field andy** - May 12 2023

web feb 28 2003 how to design and report experiments is the perfect textbook and guide to the often bewildering world of experimental design and statistics it provides a

**how to design and report experiments andy field graham** - Jun 13 2023

web how to design and report experiments is the perfect textbook and guide to the often bewildering world of experimental design and statistics it provides a complete map of

**how to design and report experiments andy field how to** - Jan 08 2023

web oct 1 2003 pmid 27702186 doi 10 7748 nr 11 1 83 s13 abstract over the years i have been in a fortunate position of being asked to review a very large number of books

**how to design and report experiments andy field** - Mar 30 2022

web how to design and report experiments by author andy field graham j hole publishers sage publications inc print format paperback

*how to design and report experiments andy field graham* - Nov 25 2021

web how to design and report experiments andy field graham hole google books how to design and report experiments is the perfect textbook and guide to the often

**how to design and report experiments field andy hole** - Feb 26 2022

web how to design and report experiments is the perfect textbook and guide to the often bewildering world of experimental design and statistics it provides a complete map of

**how to design and report experiments andy field graham** - Jul 14 2023

web dec 20 2002 how to design and report experiments is the perfect textbook and guide to the often bewildering world of experimental design and statistics it provides a