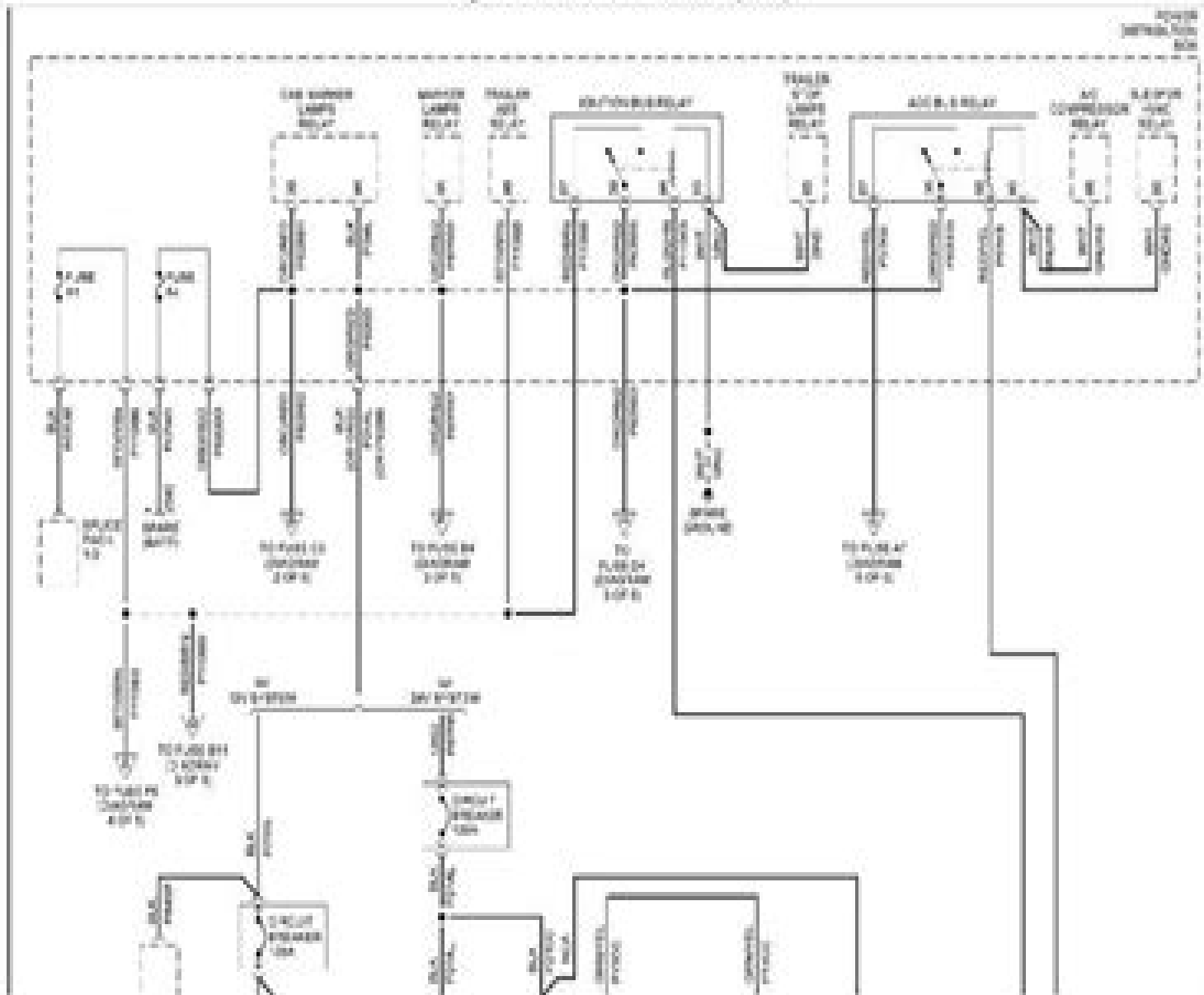

Fig. 41: Power Distribution Circuit (1 of 2)



Kenworth Wiring Schematic

Jessica J Manson



Kenworth Wiring Schematic:

Heavy Vehicle Event Data Recorder Interpretation Christopher D Armstrong,2018-11-02 The last ten years have seen explosive growth in the technology available to the collision analyst changing the way reconstruction is practiced in fundamental ways The greatest technological advances for the crash reconstruction community have come in the realms of photogrammetry and digital media analysis The widespread use of scanning technology has facilitated the implementation of powerful new tools to digitize forensic data create 3D models and visualize and analyze crash vehicles and environments The introduction of unmanned aerial systems and standardization of crash data recorders to the crash reconstruction community have enhanced the ability of a crash analyst to visualize and model the components of a crash reconstruction Because of the technological changes occurring in the industry many SAE papers have been written to address the validation and use of new tools for collision reconstruction Collision Reconstruction Methodologies Volumes 1 12 bring together seminal SAE technical papers surrounding advancements in the crash reconstruction field Topics featured in the series include Night Vision Study and Photogrammetry Vehicle Event Data Recorders Motorcycle Heavy Vehicle Bicycle and Pedestrian Accident Reconstruction The goal is to provide the latest technologies and methodologies being introduced into collision reconstruction appealing to crash analysts consultants and safety engineers alike *Fundamentals of Medium/Heavy Duty Commercial Vehicle Systems* Gus Wright,Owen C. Duffy,2019-07-15 *Fundamentals of Medium Heavy Duty Commercial Vehicle Systems* Second Edition offers comprehensive coverage of basic concepts and fundamentals building up to advanced instruction on the latest technology coming to market for medium and heavy duty trucks and buses This industry leading Second Edition includes six new chapters that reflect state of the art technological innovations such as distributed electronic control systems energy saving technologies and automated driver assistance systems *Motor* ,1943 **CCJ. Commercial Car Journal/for Fleet Management** ,1974 Some issues for 1972 for 1972 75 include section The fleet specialist **Commercial Carrier Journal for Professional Fleet Managers** ,1998-08 *Go - Transport Times of the West* ,1974 *Cars & Parts* ,1996 *Fleet Owner* ,1981 *Chilton's Commercial Carrier Journal for Professional Fleet Managers* ,1992 **Go-West** ,1956 *Simulated Nuclear Reactor System for High-temperature Process Heat* Aaron G. Starliper,Charles B. Kenahan,Charles Prasky,D. Z. Hobbs,Edward J. Murphy,Francis E. Brantley,Harry R. Nicholls,Heber E. Peterson,James T. McCartney,K. K. Kershner,Kenneth E. Tame,Leonard Obert,Neil H. Coates,R. L. Montgomery,Richard J. Leary,Robert H. Merrill,Ronald Barany,Thomas Newkirk McVay,Willard L. Hunter,J. S. MacDuff,Annie G. Smelley,David Schlain,E. J. Ostrowski,Gary A. Kingston,H. Kenworth,James G. Donaldson,James P. McGee,Joe B. Rosenbaum,Jon Peterson,R. E. Walline,R. G. Peterson,Robert Lawrence Marovelli,Thomas T. Campbell,Wilbur I. Duvall,F. E. Block,Floyd E. Joyce,George E. Fasching,Julius Bruce Clemmer,Marion W. Hovey,Nick Derick,P. T. Goin,Sabri Ergun,1961 **Automotive News of the Pacific Northwest** ,1946 **InfoWorld** ,2000-01-24 InfoWorld is targeted to Senior IT professionals Content is segmented

into Channels and Topic Centers InfoWorld also celebrates people companies and projects Automobile Engineer ,1957
 Commercial Car Journal ,1955 Beginning with 1937 the April issue of each vol is the Fleet reference annual **The**
Automobile Engineer ,1957 **National Union Catalog, 1981** ,1982 **National Union Catalog** , Includes entries for
maps and atlases *Diesel Equipment Superintendent* ,1965 **Commercial Carrier Journal** ,2000

Kenworth Wiring Schematic: Bestsellers in 2023 The year 2023 has witnessed a remarkable surge in literary brilliance, with numerous compelling novels captivating the hearts of readers worldwide. Lets delve into the realm of popular books, exploring the captivating narratives that have charmed audiences this year. Kenworth Wiring Schematic : Colleen Hoover "It Ends with Us" This touching tale of love, loss, and resilience has gripped readers with its raw and emotional exploration of domestic abuse. Hoover expertly weaves a story of hope and healing, reminding us that even in the darkest of times, the human spirit can prevail. Kenworth Wiring Schematic : Taylor Jenkins Reids "The Seven Husbands of Evelyn Hugo" This spellbinding historical fiction novel unravels the life of Evelyn Hugo, a Hollywood icon who defies expectations and societal norms to pursue her dreams. Reids captivating storytelling and compelling characters transport readers to a bygone era, immersing them in a world of glamour, ambition, and self-discovery. Kenworth Wiring Schematic : Delia Owens "Where the Crawdads Sing" This evocative coming-of-age story follows Kya Clark, a young woman who grows up alone in the marshes of North Carolina. Owens crafts a tale of resilience, survival, and the transformative power of nature, captivating readers with its evocative prose and mesmerizing setting. These bestselling novels represent just a fraction of the literary treasures that have emerged in 2023. Whether you seek tales of romance, adventure, or personal growth, the world of literature offers an abundance of captivating stories waiting to be discovered. The novel begins with Richard Papen, a bright but troubled young man, arriving at Hampden College. Richard is immediately drawn to the group of students who call themselves the Classics Club. The club is led by Henry Winter, a brilliant and charismatic young man. Henry is obsessed with Greek mythology and philosophy, and he quickly draws Richard into his world. The other members of the Classics Club are equally as fascinating. Bunny Corcoran is a wealthy and spoiled young man who is always looking for a good time. Charles Tavis is a quiet and reserved young man who is deeply in love with Henry. Camilla Macaulay is a beautiful and intelligent young woman who is drawn to the power and danger of the Classics Club. The students are all deeply in love with Morrow, and they are willing to do anything to please him. Morrow is a complex and mysterious figure, and he seems to be manipulating the students for his own purposes. As the students become more involved with Morrow, they begin to commit increasingly dangerous acts. The Secret History is a masterful and suspenseful novel that will keep you speculating until the very end. The novel is a warning tale about the dangers of obsession and the power of evil.

<http://www.armchairempire.com/book/book-search/default.aspx/homeschool%20pacing%20guide.pdf>

Table of Contents Kenworth Wiring Schematic

1. Understanding the eBook Kenworth Wiring Schematic
 - The Rise of Digital Reading Kenworth Wiring Schematic
 - Advantages of eBooks Over Traditional Books
2. Identifying Kenworth Wiring Schematic
 - Exploring Different Genres
 - Considering Fiction vs. Non-Fiction
 - Determining Your Reading Goals
3. Choosing the Right eBook Platform
 - Popular eBook Platforms
 - Features to Look for in an Kenworth Wiring Schematic
 - User-Friendly Interface
4. Exploring eBook Recommendations from Kenworth Wiring Schematic
 - Personalized Recommendations
 - Kenworth Wiring Schematic User Reviews and Ratings
 - Kenworth Wiring Schematic and Bestseller Lists
5. Accessing Kenworth Wiring Schematic Free and Paid eBooks
 - Kenworth Wiring Schematic Public Domain eBooks
 - Kenworth Wiring Schematic eBook Subscription Services
 - Kenworth Wiring Schematic Budget-Friendly Options
6. Navigating Kenworth Wiring Schematic eBook Formats
 - ePub, PDF, MOBI, and More
 - Kenworth Wiring Schematic Compatibility with Devices
 - Kenworth Wiring Schematic Enhanced eBook Features
7. Enhancing Your Reading Experience
 - Adjustable Fonts and Text Sizes of Kenworth Wiring Schematic
 - Highlighting and Note-Taking Kenworth Wiring Schematic
 - Interactive Elements Kenworth Wiring Schematic
8. Staying Engaged with Kenworth Wiring Schematic

- Joining Online Reading Communities
 - Participating in Virtual Book Clubs
 - Following Authors and Publishers Kenworth Wiring Schematic
9. Balancing eBooks and Physical Books Kenworth Wiring Schematic
- Benefits of a Digital Library
 - Creating a Diverse Reading Collection Kenworth Wiring Schematic
10. Overcoming Reading Challenges
- Dealing with Digital Eye Strain
 - Minimizing Distractions
 - Managing Screen Time
11. Cultivating a Reading Routine Kenworth Wiring Schematic
- Setting Reading Goals Kenworth Wiring Schematic
 - Carving Out Dedicated Reading Time
12. Sourcing Reliable Information of Kenworth Wiring Schematic
- Fact-Checking eBook Content of Kenworth Wiring Schematic
 - Distinguishing Credible Sources
13. Promoting Lifelong Learning
- Utilizing eBooks for Skill Development
 - Exploring Educational eBooks
14. Embracing eBook Trends
- Integration of Multimedia Elements
 - Interactive and Gamified eBooks

Kenworth Wiring Schematic Introduction

Free PDF Books and Manuals for Download: Unlocking Knowledge at Your Fingertips In today's fast-paced digital age, obtaining valuable knowledge has become easier than ever. Thanks to the internet, a vast array of books and manuals are now available for free download in PDF format. Whether you are a student, professional, or simply an avid reader, this treasure trove of downloadable resources offers a wealth of information, conveniently accessible anytime, anywhere. The advent of online libraries and platforms dedicated to sharing knowledge has revolutionized the way we consume information. No longer confined to physical libraries or bookstores, readers can now access an extensive collection of digital books and

manuals with just a few clicks. These resources, available in PDF, Microsoft Word, and PowerPoint formats, cater to a wide range of interests, including literature, technology, science, history, and much more. One notable platform where you can explore and download free Kenworth Wiring Schematic PDF books and manuals is the internet's largest free library. Hosted online, this catalog compiles a vast assortment of documents, making it a veritable goldmine of knowledge. With its easy-to-use website interface and customizable PDF generator, this platform offers a user-friendly experience, allowing individuals to effortlessly navigate and access the information they seek. The availability of free PDF books and manuals on this platform demonstrates its commitment to democratizing education and empowering individuals with the tools needed to succeed in their chosen fields. It allows anyone, regardless of their background or financial limitations, to expand their horizons and gain insights from experts in various disciplines. One of the most significant advantages of downloading PDF books and manuals lies in their portability. Unlike physical copies, digital books can be stored and carried on a single device, such as a tablet or smartphone, saving valuable space and weight. This convenience makes it possible for readers to have their entire library at their fingertips, whether they are commuting, traveling, or simply enjoying a lazy afternoon at home. Additionally, digital files are easily searchable, enabling readers to locate specific information within seconds. With a few keystrokes, users can search for keywords, topics, or phrases, making research and finding relevant information a breeze. This efficiency saves time and effort, streamlining the learning process and allowing individuals to focus on extracting the information they need. Furthermore, the availability of free PDF books and manuals fosters a culture of continuous learning. By removing financial barriers, more people can access educational resources and pursue lifelong learning, contributing to personal growth and professional development. This democratization of knowledge promotes intellectual curiosity and empowers individuals to become lifelong learners, promoting progress and innovation in various fields. It is worth noting that while accessing free Kenworth Wiring Schematic PDF books and manuals is convenient and cost-effective, it is vital to respect copyright laws and intellectual property rights. Platforms offering free downloads often operate within legal boundaries, ensuring that the materials they provide are either in the public domain or authorized for distribution. By adhering to copyright laws, users can enjoy the benefits of free access to knowledge while supporting the authors and publishers who make these resources available. In conclusion, the availability of Kenworth Wiring Schematic free PDF books and manuals for download has revolutionized the way we access and consume knowledge. With just a few clicks, individuals can explore a vast collection of resources across different disciplines, all free of charge. This accessibility empowers individuals to become lifelong learners, contributing to personal growth, professional development, and the advancement of society as a whole. So why not unlock a world of knowledge today? Start exploring the vast sea of free PDF books and manuals waiting to be discovered right at your fingertips.

FAQs About Kenworth Wiring Schematic Books

How do I know which eBook platform is the best for me? Finding the best eBook platform depends on your reading preferences and device compatibility. Research different platforms, read user reviews, and explore their features before making a choice. Are free eBooks of good quality? Yes, many reputable platforms offer high-quality free eBooks, including classics and public domain works. However, make sure to verify the source to ensure the eBook credibility. Can I read eBooks without an eReader? Absolutely! Most eBook platforms offer web-based readers or mobile apps that allow you to read eBooks on your computer, tablet, or smartphone. How do I avoid digital eye strain while reading eBooks? To prevent digital eye strain, take regular breaks, adjust the font size and background color, and ensure proper lighting while reading eBooks. What the advantage of interactive eBooks? Interactive eBooks incorporate multimedia elements, quizzes, and activities, enhancing the reader engagement and providing a more immersive learning experience. Kenworth Wiring Schematic is one of the best book in our library for free trial. We provide copy of Kenworth Wiring Schematic in digital format, so the resources that you find are reliable. There are also many Ebooks of related with Kenworth Wiring Schematic. Where to download Kenworth Wiring Schematic online for free? Are you looking for Kenworth Wiring Schematic PDF? This is definitely going to save you time and cash in something you should think about.

Find Kenworth Wiring Schematic :

homeschool pacing guide

[homebrewers companion second edition the complete joy of homebrewing masters edition](#)

homeopathic medicine for children and infants

holt mcdougal earth science interactive reader and study guide answer key

holt elements of language second course answer key

[hond op het ijs oudejaarsconference 1989](#)

~~holt spanish 2 expresate textbook answers~~

holt geometry 11 3 answers

holt physics refraction study guide

hombres sin mujeres andanzas

[homelite st 175 bc manual](#)

[homeostasis activity middle school](#)

holt earth science anticipation guide

homeopathic guide for travelers remedies for health and safety

~~honda 1500 popup service manual~~

Kenworth Wiring Schematic :

[schaum s outline of physical chemistry abebooks](#) - Aug 06 2022

schaum s outline of physical chemistry 2nd edition by clyde metz and a great selection of related books art and collectibles available now at abebooks com

schaum s outline of analytical chemistry amazon com - Jan 31 2022

jun 22 1985 master analytical chemistry with schaum snthe high performance study guide it will help you cut study time hone problem solving skills and achieve your personal best on exams students love schaum s outlines because they produce results

[schaum s outline of physical chemistry amazon ca](#) - Dec 10 2022

jul 22 1988 master physical chemistry with schaum s the high performance study guide it will help you cut study time hone problem solving skills and achieve your personal best on exams students love schaum s outlines because they produce results

schaum s outline of theory and problems of basic - Mar 01 2022

schaum s outline series mcgraw hill new york san francisco washington d c auckland bogotci caracas lisbon which are shown in table 1 1 along with the unit symbols units of all other physical quantities are derived from these table 1 1 physical quantity length mass time current t em per at u re amount of substance luminous intensity

schaum s outline of physical chemistry mheducation com sg - Apr 14 2023

schaum s is the key to faster learning and higher grades in every subject each outline presents all the essential course information in an easy to follow topic by topic format you also get hundreds of examples solved problems and practice exercises to test your skills

[schaum s outline of physical chemistry google books](#) - Aug 18 2023

schaum s is the key to faster learning and higher grades in every subject each outline presents all the essential course information in an easy to follow topic by topic format you also get

schaum s outline of physical chemistry amazon co uk - Apr 02 2022

master physical chemistry with schaum s the high performance study guide it will help you cut study time hone problem solving skills and achieve your personal best on exams students love schaum s outlines because they produce results

schaum s outline of theory and problems of physical chemistry - May 15 2023

jan 14 2023 schaum s outline of theory and problems of physical chemistry by clyde r metz 1976 mcgraw hill edition in

english

schaum s outline of physical chemistry 2nd second edition - May 03 2022

jan 1 1988 *schaum s outline of physical chemistry 2nd second edition text only unknown binding january 1 1988* by clyde metz author 4 4 out of 5 stars 49 ratings

schaum s mcgraw hill professional - Oct 08 2022

dec 11 2020 *schaum s is the key to faster learning and higher grades in every subject each outline presents all learn more show per page narrow by shopping options category schaum s easy outlines 33 items schaum s outlines 163 items schaum s quick guides 4*

schaum s outline of physical chemistry pdf 75nr9g8s3i10 - Sep 19 2023

schaum s is the key to faster learning and higher grades in every subject each outline presents all the essential course information in an easy to follow topic by topic format you also get hundreds of examples solved problems and practice exercises to test your skills this schaum s outline gives you

[schaum s outline of theory and problems of physical chemistry](#) - Mar 13 2023

theory and problems of physical chemistry series schaum s outline series schaum s outline series in science note includes index isbn 0070417156 9780070417151

schaum s outline of physical chemistry 2nd edition 0070417156 - Jun 04 2022

schaum s outline series includes index 1 chemistry physical and theoretical problems exercises etc title ii title theory and problems of physical chemistry

schaum s outline of physical chemistry 2nd edition - Jul 17 2023

jul 1 1988 *from the back cover master physical chemistry with schaum s the high performance study guide it will help you cut study time hone problem solving skills and achieve your personal best on exams students love schaum s outlines because they produce results*

schaum s outline of physical chemistry mhprofessional com - Jun 16 2023

schaum s is the key to faster learning and higher grades in every subject each outline presents all the essential course information in an easy to follow topic by topic format you also get hundreds of examples solved problems and practice exercises to test your skills

schaum s outlines wikipedia - Nov 09 2022

schaum s outlines is a series of supplementary texts for american high school ap and college level courses currently published by mcgraw hill education professional a subsidiary of mcgraw hill education

schaum s outline of theory and problems of physical chemistry goodreads - Feb 12 2023

schaum s is the key to faster learning and higher grades in every subject each outline presents all the essential course information in an easy to follow topic by topic format you also get hundreds of examples solved problems and practice exercises to test your skills

buy schaum s outline of physical chemistry schaum s outline series - Jul 05 2022

amazon in buy schaum s outline of physical chemistry schaum s outline series book online at best prices in india on amazon in read schaum s outline of physical chemistry schaum s outline series book reviews author details and more at amazon in free delivery on qualified orders

3 000 solved problems in chemistry schaum s outline series - Jan 11 2023

jan 31 2011 format paperback isbn 9780071755009 this powerful problem solver gives you 3 000 problems in chemistry fully solved step by step from schaum the originator of the solved problem guide and studentso favorite with over 30 million study guides soldnthis timesaver helps you master every type of general chemistry problem that you will face

[schaum chemistry pdf scribd](#) - Sep 07 2022

schaum chemistry free ebook download as pdf file pdf text file txt or read book online for free schaum chemistry

25 question test forensic toxicology quiz mock test - Aug 15 2023

web forensic toxicology quiz welcome to your forensic toxicology quiz 1 which of the following are the antidotes in case of methanol poisoning b and d only c and d only a and b only a and c only 2 apart from its local anesthetic activity lidocaine is also used as analgesic drug immuno suppressant drug antiarrhythmic drug antiepileptic drug 3

domain i conduct of toxicology studies abtox org - Nov 06 2022

web the sample exam questions provided are representative of the new exam format that was implemented in 2017 and updated in 2022 domain i conduct of toxicology studies 1 in a reproductive toxicity study what is the fertility index a the percentage of live fetuses per litter b the percentage of attempted matings that result in pregnancies

[15 questions with answers in forensic toxicology](#) - Jan 08 2023

web apr 13 2021 questions related to forensic toxicology anna arakelian asked a question related to forensic toxicology the same lc ms for forensic toxicological and chemical expertises question 3

toxicology how it s done forensic science simplified - Apr 30 2022

web specimens sent for toxicology testing are usually collected by the forensic pathologist who may also be an appointed medical examiner or coroner in some jurisdictions or mortuary technician during an autopsy specimens must be properly identified labelled and sealed as soon as practicable after collection

pdf forensic medicine toxicology exam model - Aug 03 2022

web oct 20 2016 pdf exam model in forensic medicine and clinical toxicology mcqs answers find read and cite all the

research you need on researchgate

[quiz worksheet forensic toxicology study com](#) - Apr 11 2023

web about this quiz worksheet complete the quiz and worksheet to gauge your understanding of forensic toxicology topics this field is concerned with and what might prompt the initiation of a

[module one test your knowledge quiz toxicology curriculum](#) - Feb 09 2023

web module one test your knowledge quiz español spanish print 1 which of these groups is usually designated as one of the most sensitive sub populations for exposures to toxic substances a adult women b infants c adult men

[forensic toxicology an overview sciencedirect topics](#) - Jun 01 2022

web abstract forensic toxicology is a part of the science of pharmacology which is concerned with the quantities and effects of various drugs and poisons on human beings in forensic toxicology the main interest is the extent to which drugs and poisons may have contributed to impairment or death

forensic toxicology abft prep - Oct 05 2022

web forensic toxicology abft prep this 17 module on demand online course consists of a combination of in depth lectures self study and practice exams covering all areas of the study curriculum that would comprise a forensic toxicology certification examination

[forensic toxicology practice test questions chapter exam study](#) - Jul 14 2023

web test and improve your knowledge of forensic toxicology with fun multiple choice exams you can take online with study com

pdf forensic toxicology mcqs study aids researchgate - Dec 07 2022

web may 28 2020 forensic toxicology mcqs study aids doi authors minani theobald university of rwanda abstract forensic toxicology is the branch of science that deal with poison together with analytical

forensics toxicology flashcards quizlet - Jul 02 2022

web study with quizlet and memorize flashcards containing terms like what is the role of a toxicologist who might a toxicologist work with when determining cod what are the 4 disciplines of forensic toxicology and more

100 mcqs on forensic toxicology forensic s blog - Jun 13 2023

web home mcqs 100 mcqs on forensic toxicology 100 mcqs on forensic toxicology 1 the antidote of endrin is a atropin b paralidoxime c bal d none of the above answer d 2 which one can caused blindness a ethyl alcohol b methyl alcohol c glycol d propanol answer b 3

a simplified guide to forensic toxicology - Sep 04 2022

web toxicology tests or be helpful in theinvestigation postmortemblood presents problems due to often variable condition

and changes to concentrations from one place to another in the body after death

drug analysis forensic resources - Jan 28 2022

web drug analysis is the testing of a suspected controlled substance to determine its composition for information about forensic toxicology or the testing of bodily fluids for controlled substances click here understanding test results every analysis of a suspected controlled substance should consist of at least two tests the first is a presumptive or

quiz quizizz - Dec 27 2021

web forensic toxicologists today are responsible for a wide range of duties which of the following is not the responsibility of a toxicologist analyze body fluids from an autopsy

forensic toxicology flashcards quizlet - Mar 30 2022

web forensic toxicology flashcards learn opre 4310 statistics quiz 77 terms angeleanachan opre 4330 test 1 46 terms angeleanachan opre 3311 quiz 1 69 terms angeleanachan chinese ii 18 79 terms angeleanachan verified questions earth science a inch balloon is the smallest mylar balloon that can be inflated with

forensic toxicology multiple choice questions mcqs - Mar 10 2023

web forensic toxicology multiple choice questions mcqs pdf read online for free 1 according to the history of forensic toxicology the following are correct except a orfila is the father of forensic toxicology b

forensic toxicology exam 1 questions flashcards quizlet - May 12 2023

web study with quizlet and memorize flashcards containing terms like which is not a sub discipline of forensic toxicology a workplace drug testing b human performance toxicology c clinical toxicology d post mortem toxicology which of the following are performed by the forensic toxicologist check all that apply a

forensic toxicology intechopen - Feb 26 2022

web jun 19 2019 forensic toxicology is mainly concerned with the determination of the presence or absence and role of alcohol drugs and their metabolites as well as other toxic substances in biological fluids and or tissues to solve a medico legal problem 5

physical sciences paper 1 grade 12 memorandum nsc exams past papers - Aug 02 2022

web mar 7 2022 physical sciences physics paper 1 grade 12 national senior certificate memorandum november 2020 question 1 1 1 b 2 1 2 d 2 1 3 c 2 1 4 c 2 1 5 c 2 1 6 a 2 1 7 a 2 1 8 d 2 1 9 a 2 1 10 b 2 20 question 2 2 1 marking criteria *physical sciences paper 1 memorandum grade 12 september* - May 31 2022

web mar 3 2022 physical sciences paper 1 memorandum grade 12 september 2021 preparatory exams elimuza access to education thursday 03 march 2022 06 48 physical sciences paper 1 memorandum grade 12

grade 11 november 2022 physical sciences - Jul 13 2023

web 6 1 1 calculate the number of electrons that were removed from q 1 to give it a charge of $4.5 \times 10^{-9} \text{ C}$ assume that the sphere was neutral before being charged 3 6 1 2 draw a labelled free body diagram showing all the forces acting on sphere q 1 3 6 1 3 state coulomb s law in words 2

2021 p5 science practice paper 1 scgs pdf sg exam - Jul 01 2022

web feb 1 2022 2021 p5 science weighted assessment 1 catholic high pdf 2021 p5 science weighted assessment 1 henry park pdf 2021 p5 science weighted assessment 1 maha bodhi pdf

grade 11 physical science ps physics november paper 1 and memo - Oct 04 2022

web grade 11 physical sciences november paper 1 and memo total 150 marks this exam paper covers the following work physics vectors in 2d newton s laws newton s universal law electrostatics electromagnetism electric circuits this is a practice paper with memorandum meant to test the student s knowledge and will not be the same

physical sciences grade 12 past exam papers and memos - Apr 29 2022

web physical sciences nsc p1 memo sept 2016 eng north west physical sciences nsc p2 qp sept 2016 eng north west welcome to the grade 12 physical sciences physics past exam paper page here you ll find a comprehensive range of past papers and memos from 2023 to 2008

grade 11 physical science ps physics november paper 1 and memo - Sep 15 2023

web nov 14 2023 grade 11 physical sciences november paper 1 and memo total 150 marks this exam paper covers the following work physics vectors in 2d newton s laws newton s universal law electrostatics electromagnetism electric circuits this is a practice paper with memorandum meant to test the student s knowledge and will not

nsc nov 2021 physical sciences p1 marking guideline - Dec 06 2022

web apr 13 2022 this is physical sciences paper 1 memo for national senior certificate november 2021 grade 12 learners will benefit greatly when using it as part of their examination preparation

grade 11 november 2020 physical sciences p1 exemplar - Oct 16 2023

web physical sciences p1 exemplar marks 150 time 3 hours this question paper consists of 19 pages including 2 datasheets this question paper consists of ten questions answer all the questions in the answer book 3 start each question on a new page 4 number the answers correctly according to the numbering system used in

download grade 12 physical sciences past exam papers and - Apr 10 2023

web apr 2 2020 by katlego sithole download grade 12 physical sciences past exam papers and memorandums here s a collection of past physical sciences papers plus memos to help you prepare for the matric finals 2018 asc may june 2018 physical sciences paper 1 memorandum 2018 physical sciences paper 2 memorandum

national senior certificate grade 12 - Aug 14 2023

web this question paper consists of 17 pages and 3 data sheets grade 12 national 12 write your examination number and centre number in the appropriate spaces on the answer book this question paper consists of ten questions answer all the questions in the answer book physical sciences p1 12 db e november 2019 nsc

grade 10 physics physical sciences paper 1 term 1 test - Sep 03 2022

web mar 13 2023 physics physical sciences paper 1 term 1 test with memo for grade 10 out of 50 marks duration is 60 minutes topic waves note this material was developed and moderated by qualified teachers

nsc physical sciences grade 12 may june 2023 p1 only 2 - Feb 25 2022

web physical science instructioi physical sciences p1 sc nsc question 4 start on a new page 10 11 12 write on thi this the a start numl quest leav que you 1 you i shov rour give you writE trolley a of mass 7 2 kg moves to the right at 0 4 ms i in a straight line on a horizontal floor it collides with a stationary trolley b of mass 5 3 kg

grade 11 physical sciences november paper 1 - Nov 05 2022

web r 40 00 incl vat grade 11 physical sciences november paper 1 and memo total 150 marks this exam paper covers the following work physics vectors in 2d newton s laws newton s universal law electrostatics electromagnetism electric circuits this is a practice paper with memorandum meant to test the student s knowledge

may june 2021 grade 12 physical sciences paper 1 memorandum - May 11 2023

web this may june 2021 grade 12 physical sciences paper 1 physics question paper touches on newton s laws of motion vertical projectile motion work energy power doppler effect

physical sciences p1 nov 2023 grade 11 memo studocu - Feb 08 2023

web nov 1 2023 9 9 1 the magnitude of the induced emf across the ends of a conductor is directly proportional to the rate of change in the magnetic flux linked with the conductor 2 9 1 south 1 9 1 no deflection zero reading no change in the magnetic flux linkage 2 9 1 y to x 1 9 2 9 2 ϕ ba $\cos\theta$ 0 5 0 $\cos 20^\circ$ 4 70 x 10⁴ wb

ec physical science grade 10 november 2022 p1 and memo 1 - Mar 29 2022

web nov 10 2022 ai chat ec physical science grade 10 november 2022 p1 and memo 1 school northwood school south africa subject a level physics a level physics 9702 derecho civil civil law introduccion derecho de la persona derecho subjetivo

grade 11 physical science ps physics november paper 1 and memo - Jan 07 2023

web r 40 00 grade 11 physical sciences november paper 1 and memo total 150 marks this exam paper covers the following work physics vectors in 2d newton s laws newton s universal law electrostatics electromagnetism electric circuits this is a practice paper with memorandum meant to test the student s knowledge and will not

grade 10 physical science ps physics november paper 1 and memo - Jun 12 2023

web nov 13 2023 the total price includes the item price and a buyer fee grade 10 physical sciences november paper 1 and

memo total 100 marks this exam paper covers the following work mechanics waves sound light electricity magnetism this is a practice paper with memorandum meant to test the student s knowledge and will not

physical science exam papers and study material for grade 12 - Mar 09 2023

web physical sciences p1 memo a e physical sciences p2 memo exam papers grade 12 physical science the latest papers with memoranda are available for downloading to improve your understanding