

## FAST-HITCH

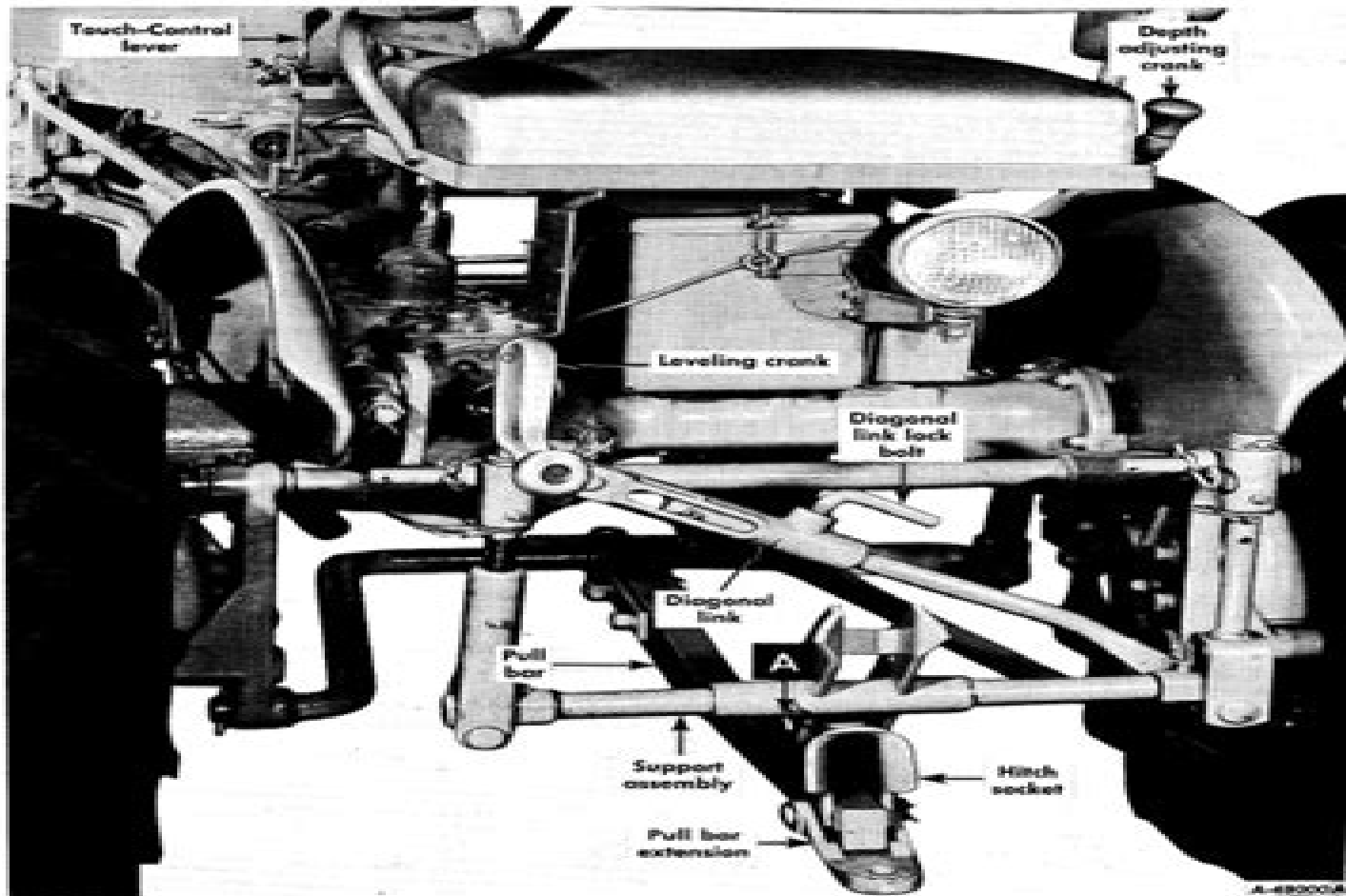

Illustr. 15  
Rear view of Farmall Cub Tractor with Fast-Hitch.

# Mccormick Farmall Cub Service Manual

**Tharran E Gaines**



**Mccormick Farmall Cub Service Manual:**

Delve into the emotional tapestry woven by Crafted by in **Mccormick Farmall Cub Service Manual** . This ebook, available for download in a PDF format ( Download in PDF: \*), is more than just words on a page; it's a journey of connection and profound emotion. Immerse yourself in narratives that tug at your heartstrings. Download now to experience the pulse of each page and let your emotions run wild.

[http://www.armchairempire.com/book/uploaded-files/HomePages/Hesi\\_A2\\_Study\\_Guide\\_Free.pdf](http://www.armchairempire.com/book/uploaded-files/HomePages/Hesi_A2_Study_Guide_Free.pdf)

## **Table of Contents Mccormick Farmall Cub Service Manual**

1. Understanding the eBook Mccormick Farmall Cub Service Manual
  - The Rise of Digital Reading Mccormick Farmall Cub Service Manual
  - Advantages of eBooks Over Traditional Books
2. Identifying Mccormick Farmall Cub Service Manual
  - Exploring Different Genres
  - Considering Fiction vs. Non-Fiction
  - Determining Your Reading Goals
3. Choosing the Right eBook Platform
  - Popular eBook Platforms
  - Features to Look for in an Mccormick Farmall Cub Service Manual
  - User-Friendly Interface
4. Exploring eBook Recommendations from Mccormick Farmall Cub Service Manual
  - Personalized Recommendations
  - Mccormick Farmall Cub Service Manual User Reviews and Ratings
  - Mccormick Farmall Cub Service Manual and Bestseller Lists
5. Accessing Mccormick Farmall Cub Service Manual Free and Paid eBooks
  - Mccormick Farmall Cub Service Manual Public Domain eBooks
  - Mccormick Farmall Cub Service Manual eBook Subscription Services
  - Mccormick Farmall Cub Service Manual Budget-Friendly Options

6. Navigating Mccormick Farmall Cub Service Manual eBook Formats
  - ePub, PDF, MOBI, and More
  - Mccormick Farmall Cub Service Manual Compatibility with Devices
  - Mccormick Farmall Cub Service Manual Enhanced eBook Features
7. Enhancing Your Reading Experience
  - Adjustable Fonts and Text Sizes of Mccormick Farmall Cub Service Manual
  - Highlighting and Note-Taking Mccormick Farmall Cub Service Manual
  - Interactive Elements Mccormick Farmall Cub Service Manual
8. Staying Engaged with Mccormick Farmall Cub Service Manual
  - Joining Online Reading Communities
  - Participating in Virtual Book Clubs
  - Following Authors and Publishers Mccormick Farmall Cub Service Manual
9. Balancing eBooks and Physical Books Mccormick Farmall Cub Service Manual
  - Benefits of a Digital Library
  - Creating a Diverse Reading Collection Mccormick Farmall Cub Service Manual
10. Overcoming Reading Challenges
  - Dealing with Digital Eye Strain
  - Minimizing Distractions
  - Managing Screen Time
11. Cultivating a Reading Routine Mccormick Farmall Cub Service Manual
  - Setting Reading Goals Mccormick Farmall Cub Service Manual
  - Carving Out Dedicated Reading Time
12. Sourcing Reliable Information of Mccormick Farmall Cub Service Manual
  - Fact-Checking eBook Content of Mccormick Farmall Cub Service Manual
  - Distinguishing Credible Sources
13. Promoting Lifelong Learning
  - Utilizing eBooks for Skill Development
  - Exploring Educational eBooks
14. Embracing eBook Trends
  - Integration of Multimedia Elements

- 
- Interactive and Gamified eBooks

## **Mccormick Farmall Cub Service Manual Introduction**

Mccormick Farmall Cub Service Manual Offers over 60,000 free eBooks, including many classics that are in the public domain. Open Library: Provides access to over 1 million free eBooks, including classic literature and contemporary works. Mccormick Farmall Cub Service Manual Offers a vast collection of books, some of which are available for free as PDF downloads, particularly older books in the public domain. Mccormick Farmall Cub Service Manual : This website hosts a vast collection of scientific articles, books, and textbooks. While it operates in a legal gray area due to copyright issues, its a popular resource for finding various publications. Internet Archive for Mccormick Farmall Cub Service Manual : Has an extensive collection of digital content, including books, articles, videos, and more. It has a massive library of free downloadable books. Free-eBooks Mccormick Farmall Cub Service Manual Offers a diverse range of free eBooks across various genres. Mccormick Farmall Cub Service Manual Focuses mainly on educational books, textbooks, and business books. It offers free PDF downloads for educational purposes. Mccormick Farmall Cub Service Manual Provides a large selection of free eBooks in different genres, which are available for download in various formats, including PDF. Finding specific Mccormick Farmall Cub Service Manual, especially related to Mccormick Farmall Cub Service Manual, might be challenging as theyre often artistic creations rather than practical blueprints. However, you can explore the following steps to search for or create your own Online Searches: Look for websites, forums, or blogs dedicated to Mccormick Farmall Cub Service Manual, Sometimes enthusiasts share their designs or concepts in PDF format. Books and Magazines Some Mccormick Farmall Cub Service Manual books or magazines might include. Look for these in online stores or libraries. Remember that while Mccormick Farmall Cub Service Manual, sharing copyrighted material without permission is not legal. Always ensure youre either creating your own or obtaining them from legitimate sources that allow sharing and downloading. Library Check if your local library offers eBook lending services. Many libraries have digital catalogs where you can borrow Mccormick Farmall Cub Service Manual eBooks for free, including popular titles. Online Retailers: Websites like Amazon, Google Books, or Apple Books often sell eBooks. Sometimes, authors or publishers offer promotions or free periods for certain books. Authors Website Occasionally, authors provide excerpts or short stories for free on their websites. While this might not be the Mccormick Farmall Cub Service Manual full book , it can give you a taste of the authors writing style. Subscription Services Platforms like Kindle Unlimited or Scribd offer subscription-based access to a wide range of Mccormick Farmall Cub Service Manual eBooks, including some popular titles.

---

**FAQs About Mccormick Farmall Cub Service Manual Books**

1. Where can I buy Mccormick Farmall Cub Service Manual books? Bookstores: Physical bookstores like Barnes & Noble, Waterstones, and independent local stores. Online Retailers: Amazon, Book Depository, and various online bookstores offer a wide range of books in physical and digital formats.
2. What are the different book formats available? Hardcover: Sturdy and durable, usually more expensive. Paperback: Cheaper, lighter, and more portable than hardcovers. E-books: Digital books available for e-readers like Kindle or software like Apple Books, Kindle, and Google Play Books.
3. How do I choose a Mccormick Farmall Cub Service Manual book to read? Genres: Consider the genre you enjoy (fiction, non-fiction, mystery, sci-fi, etc.). Recommendations: Ask friends, join book clubs, or explore online reviews and recommendations. Author: If you like a particular author, you might enjoy more of their work.
4. How do I take care of Mccormick Farmall Cub Service Manual books? Storage: Keep them away from direct sunlight and in a dry environment. Handling: Avoid folding pages, use bookmarks, and handle them with clean hands. Cleaning: Gently dust the covers and pages occasionally.
5. Can I borrow books without buying them? Public Libraries: Local libraries offer a wide range of books for borrowing. Book Swaps: Community book exchanges or online platforms where people exchange books.
6. How can I track my reading progress or manage my book collection? Book Tracking Apps: Goodreads, LibraryThing, and Book Catalogue are popular apps for tracking your reading progress and managing book collections. Spreadsheets: You can create your own spreadsheet to track books read, ratings, and other details.
7. What are Mccormick Farmall Cub Service Manual audiobooks, and where can I find them? Audiobooks: Audio recordings of books, perfect for listening while commuting or multitasking. Platforms: Audible, LibriVox, and Google Play Books offer a wide selection of audiobooks.
8. How do I support authors or the book industry? Buy Books: Purchase books from authors or independent bookstores. Reviews: Leave reviews on platforms like Goodreads or Amazon. Promotion: Share your favorite books on social media or recommend them to friends.
9. Are there book clubs or reading communities I can join? Local Clubs: Check for local book clubs in libraries or community centers. Online Communities: Platforms like Goodreads have virtual book clubs and discussion groups.
10. Can I read Mccormick Farmall Cub Service Manual books for free? Public Domain Books: Many classic books are available for free as they're in the public domain. Free E-books: Some websites offer free e-books legally, like Project Gutenberg or Open Library.

---

**Find Mccormick Farmall Cub Service Manual :**

**hesi a2 study guide free**

**hesston 4755 operators manual**

~~hesston 4655 baler manual~~

het feest is afgelopen

**heritage studies 4 worktext answer key 2nd edition**

het huisje in de steeg jeugdroman gellustreerd henk poeder

het engeltje van kampong rhanka

here we stand where nazarenes fit in the religious marketplace

**het wonder van leiden roman**

~~heroes del acero librojuego~~

het geluid van stilte

*heroes of olympus and the blood of olympus free epub download*

hesi a2 admission assesment exam study guide

~~het assepoester complex~~

hes only a prayer away 9 examples of praying until your breakthrough

**Mccormick Farmall Cub Service Manual :**

creole jazz band fake book 1 c treble doc database - May 31 2022

web creole jazz band fake book 1 c treble tweet this pdf file is prepared as a sample of pdf file we will prepare for you and you can download it for free on docdatabase net

**creole jazz band fake book ver 2 4 bb treble pdf pdf room** - Feb 08 2023

web this fakebook has been produced in the following versions c treble bb treble eb treble bass clef f horn if you want versions in other keys or want more tunes added feel

**pdf creole jazz band fake book 1 c treble largest pdf** - Dec 06 2022

web the blues and jazz chords by using the number of the note they re built on king oliver s creole jazz band dippermouth blues recorded 1923

*fake book 1 massifjazz com* - Jun 12 2023

web this fake book has been assembled with tunes that have all been written prior to 1923 therefore these are all out of



copyright in the usa i hope you enjoy the tunes this

**fake book 1 mr maglocchi** - Nov 24 2021

web i hope you enjoy the tunes this fakebook has been produced in the following versions c treble bb treble eb treble bass clef tuba bass clef one octave lower if you want

**fake book 1 massifjazz com** - Dec 26 2021

web this fakebook has been produced in the following versions c treble bb treble eb treble bass clef tuba bass clef one octave lower if you want versions in other keys or want

*fake book 1 c pdf 6 27 mb pdf room* - Apr 10 2023

web apr 14 2020 download pdf convert to view on amazon read pdf online read online summary of fake book 1 c page 1 fake book 1 pre 1923 ver 1 1 c

**the creole jazz band fake book 1 c sciarium** - Nov 05 2022

web jul 4 2015 note sheets the creole jazz band fake book 1 c pdf file size 6 27 mb added by mareq 07 04 2015 00 45 info modified 07 04 2015 07 58 oldtime jazz

**creole jazz band fake book 1 c treble pdf** - Feb 25 2022

web onslaught of noise and distractions however located within the musical pages of creole jazz band fake book 1 c treble a charming work of fictional splendor that impulses

*creole jazz band fake book 2022 version now available* - Mar 09 2023

web jan 20 2022 1 20 2022 2 comments the amazing kevin yeates and the lads from the creole jazz band have released the 2022 version of the famous creole jazz band

Скачать the creole jazz band fake book 1 c pdf - Oct 24 2021

web apr 7 2015 the creole jazz band fake book 1 c Файл формата pdf размером 6 27 МБ Добавлен пользователем mareq 04 07 15 00 45 Описание отредактировано

**fake book 1 c pdf ldq1m30annc0 e book library** - May 11 2023

web fake book 1 pre 1923 ver 1 1 c treble the creole jazz band wordmark was created by madeline koeberling thanks to madeline s patience with us her incredibly thorough

*creole jazz band fake book 2023 version simply early jazz* - Apr 29 2022

web the 2021 edition was put out in 2021 this 2023 edition is put out in 2023 we hope this will make it easier for everyone to keep up to date with the latest edition on behalf of the

**download fake book 1 bb pdf by the creole jazz band** - Jul 01 2022

web table of content fake book 1 pre 1923 ver 1 1 bb the creole jazz band wordmark was created by madeline koeberling

---

thanks to madeline s patience with us her

**creole jazz band fake book i gig book** - Jan 07 2023

web feb 25 2013 to get the pdf select creole jazz band fake book 1 from the book list view and the pdf will download and link to the index this pdf comes courtesy of the

**fake book version 2 massifjazz com** - Aug 02 2022

web this fake book has been assembled with tunes that have been written prior to 1923 which makes them out of copyright in the usa this fakebook has been produced in the

creole jazz band fake book 1 c treble henry clay warmoth - Jan 27 2022

web possibilities the book also provides practical instructions and playing tips so you can get the most out of playing each song includes alexander s ragtime band all of you

**the creole jazz band fakebook archive org** - Aug 14 2023

web jul 10 2019 fakebook with public domain jazz tunes collected by the creole jazz band several versions for c bb eb f instruments as well as bass clef and tuba

fake book version 2 massifjazz com - Sep 03 2022

web fake book version 2 2 c treble the creole jazz band wordmark was created by madeline koerberling thanks to madeline s patience with us her incredibly thorough

*creole fake book pdf clef ragtime scribd* - Oct 04 2022

web fake book 1 pre 1923 ver 1 1 c treble the creole jazz band wordmark was created by madeline koerberling thanks to madeline s patience with us her incredibly thorough

**fake book 1 massifjazz com** - Jul 13 2023

web this fakebook has been produced in the following versions c treble bb treble eb treble bass clef tuba bass clef one octave lower if you want versions in other keys or want

the creole jazz band fake book 1 eb pdf scribd - Mar 29 2022

web this fakebook has been produced in the following versions c treble bb treble eb treble bass clef tuba bass clef one octave lower if you want versions in other keys or want

**test1 ch15 kinetics practice problems minnesota state** - Aug 05 2023

web extra practice problems general types groups of problems rates of change in chemical reactions for the reaction a 3b à 2c how does the rate of disappearance of b compare to the rate of production of c

*chm 112 kinetics practice problems answers university of* - Sep 25 2022

web practice problems chemical kinetics rates and mechanisms of chemical reactions 1 state two quantities that must be

measured to establish the rate of a chemical reaction and cite several factors that affect the rate of a chemical reaction

answer the rate of a reaction is defined as the change in concentration as a function of time

[chemical kinetics questions practice questions of chemical kinetics](#) - Aug 25 2022

web chemical kinetics questions and answers practice questions mcqs pyqs ncert questions question bank class 11 and class 12 questions ncert exemplar questions and pdf questions with answers solutions explanations ncert reference and difficulty level in chemical kinetics chemistry

[10 e enzyme kinetics exercises chemistry libretexts](#) - Jun 22 2022

web an solution initially contains a catalytic amount of an enzyme with  $k_m = 1.5 \text{ mmol/L}$  of substrate and no product after 45 seconds the solution contains  $25 \mu\text{m}$  of product find  $v_{max}$  and the concentration of product after 20 minutes hint  $s = k_m$

[reaction mechanisms practice kinetics khan academy](#) - Jan 30 2023

web a reaction and its experimental rate law are represented below  $2 \text{ ICl} + \text{H}_2 \text{g} \rightarrow 2 \text{ HI} + 2 \text{ HCl} \text{g}$  rate  $k [\text{ICl}]^2 [\text{H}_2]$  a chemist proposes a mechanism for the reaction that is consistent with the rate law the mechanism has two elementary steps and the first step is slow compared to the second

**thermodynamics questions practice questions of chemical kinetics** - Feb 16 2022

web chemical kinetics questions and answers practice questions mcqs pyqs ncert questions question bank class 11 and class 12 questions ncert exemplar questions and pdf questions with answers solutions explanations ncert reference and difficulty level in chemical kinetics chemistry

[chm 112 kinetics practice problem university of rhode island](#) - Oct 27 2022

web practice problems chemical kinetics rates and mechanisms of chemical reactions 1 state two quantities that must be measured to establish the rate of a chemical reaction and cite several factors that affect the rate of a chemical reaction

[kinetics practice problems chemistry steps](#) - Sep 06 2023

web kinetics practice problems this summary practice problem set covers the most common topics of chemical kinetics you will find questions on the reaction rate rate constant rate law integrated rate law reaction half life and some more

[chemical kinetics solved example problems chemistry](#) - Nov 27 2022

web solution a first order with respect to  $\text{Br}_2$  first order with respect to  $\text{BrO}_3^-$  and second order with respect to  $\text{H}^+$  hence the overall order of the reaction is equal to 1 + 1 + 2 = 4 b order of the reaction with respect to acetaldehyde is 3/2 and overall order is also 3/2

[intro to chemical kinetics practice problems pearson](#) - Feb 28 2023

web 1 practice problem stove burners are connected to nozzles that regulate the steady flow and supply of gas when the nozzle is clogged there is an interference in the flow of gas which affects the performance of the burner which of the

following best describes this scenario and the effect on the kinetics 2 practice problem

[chemical kinetics practice test questions chapter exam study](#) - May 22 2022

web chemical kinetics chapter exam free practice test instructions choose your answer to the question and click continue to see how you did then click next question to answer the next question

[kinetics questions practice kinetics khan academy](#) - Jun 03 2023

web course mcat unit 9 lesson 18 kinetics kinetics questions introduction to reaction rates rate law and reaction order

worked example determining a rate law using initial rates data first order reaction with calculus plotting data for a first order reaction half life of a first order reaction

**9 e chemical kinetics exercises chemistry libretexts** - May 02 2023

web dec 26 2015 in the nuclear industry workers use a rule of thumb that the radioactivity from any sample will be relatively harmless after 10 half lives calculate the fraction of a radioactive sample that remains after this time period hint radioactive decay obeys first

**worksheet 14 chemical kinetics chemistry libretexts** - Jul 04 2023

web in order to have successful collisions the colliding particles must have both the proper amount of energy and the proper fill in blank draw an energy diagram which shows the shape of the curve you might expect for the reaction in this question the overall reaction is exothermic

**kinetics i worksheet chemistry libretexts** - Dec 29 2022

web mar 13 2023 work in groups on these problems you should try to answer the questions without referring to your textbook if you get stuck try asking another group for help 1 for the reaction below if substance a is disappearing at a rate of  $1.82 \times 10^{-2} \text{ mol l}^{-1} \text{ s}^{-1}$  at what rate is c appearing 3 a 3 b  $\rightarrow$  5 c 2 d

[kinetics practice problems and solutions loudoun county public schools](#) - Jul 24 2022

web kinetics practice problems and solutions d write the rate law for the overall reaction rate  $k_a = 2.9$  consider the following mechanism o 3 o 2 o fast o 3 o 2 o 2 slow a write the overall balanced chemical equation 2 o 3 3 o 2 b identify any intermediates within the mechanism o c what is the order with respect

[chemical kinetics quiz questions with solutions vedantu](#) - Apr 20 2022

web chemical kinetics practice problems with solutions solve these chemical kinetics questions and sharpen your practice problem solving skills we have quizzes covering each and every topic of physical chemistry and other concepts of chemistry

[kinetics practice problems and solutions lecture notes chemical](#) - Mar 20 2022

web a2 1 st b2 1 st kinetics practice problems and solutions d write the rate law for the overall reaction rate  $k_a = 2.9$

consider the following mechanism o3 o2 o fast o3 o 2 o2 slow a write the overall balanced chemical equation 2 o3 3 o2 b

identify any intermediates within the mechanism of

*reaction rates practice kinetics khan academy* - Apr 01 2023

web reaction rates google classroom mg s + 2 hcl a q → mgcl<sub>2</sub> a q + h<sub>2</sub> g the reaction between mg s and hcl a q is represented by the equation above in a kinetics experiment a 0.080 g sample of mg s ribbon is added to an erlenmeyer flask containing 50 ml of 3.0 m hcl a q at 25 °c

*1 e kinetics practice problems with answers* - Oct 07 2023

web jan 10 2021 studying chemical kinetics determines whether to proceed with a reaction as it measures the rate of a reaction reactions conducted in an industrial facility mix compounds together heating and stirring them for a

independent reading a guide to let the circle be unbroken - Jun 13 2023

web independent reading a guide to let the circle be unbroken the circle jan 26 2020 from usa today washington post and amazon charts bestselling author comes an exhilarating new ya series the world's landscape was drastically altered when the atomic war devastated humanity a

let the circle be unbroken summary study guide - Jan 08 2023

web let the circle be unbroken is a story of a small mississippi town in the 1930s and the troubles that plague its black community picking up where its precursor roll of thunder hear my cry leaves off mildred taylor recounts the trials of this small community through the characters of the logan family more specifically it focuses on the children of the

independent reading a guide to let the circle be unbroken - Feb 26 2022

web independent reading a guide to let the circle be unbroken author blogs post gazette com 2023 09 06t00 00 00 00 01

subject independent reading a guide to let the circle be unbroken keywords independent reading a guide to let the circle be unbroken created date 9 6 2023 4 55 01 am

**independent reading a guide to let the circle be unbroken** - Jun 01 2022

web with this independent reading a guide to let the circle be unbroken but stop in the works in harmful downloads rather than enjoying a good book in the manner of a cup of coffee in the afternoon on the other hand they juggled when

let the circle be unbroken summary supersummary - Jul 02 2022

web let the circle be unbroken fiction novel middle grade published in 1981 a modern alternative to sparknotes and cliffsnotes supersummary offers high quality study guides that feature detailed chapter summaries and analysis of major themes characters quotes and essay topics download pdf

**independent reading a guide to let the circle be unbroken** - Feb 09 2023

web dec 11 2022 independent reading a guide to let the circle be unbroken 1 3 downloaded from ads independent com on december 11 2022 by guest independent reading a guide to let the circle be unbroken when somebody should go to the book

stores search commencement by shop shelf by shelf it is really problematic

**let the circle be unbroken penguin random house** - Dec 07 2022

web let the circle be unbroken a stunning repackaged companion to mildred d taylor scroll of thunder hear my cry with cover art by two time caldecott honor award winner kadir nelson it is a frightening and turbulent time for the logan family

**let the circle be unbroken literary elements gradesaver** - Aug 03 2022

web let the circle be unbroken study guide contains a biography of mildred taylor literature essays quiz questions major themes characters and a full summary and analysis best summary pdf themes and quotes more books than sparknotes

**independent reading a guide to let the circle be unbroken** - Dec 27 2021

web may 25 2023 unbroken independent reading a guide to let the circle be unbroken let the circle be unbroken the implications of african read document online 2018 independent reading a guide to let the circle be unbroken radio replacement guide for ford ranger ford mountaineer mercury b2200 complete summary of mildred

**independent reading a guide to let the circle be unbroken** - Mar 30 2022

web independent reading a guide to let the circle be unbroken 5 5 reading a guide to nothing but the truth was published by on 2015 06 22 find more similar flip pdfs like independent reading a guide to nothing but the truth download independent reading a guide to nothing but the truth pdf for free independent reading a guide to

**let the circle be unbroken study guide gradesaver** - May 12 2023

web let the circle be unbroken study guide contains a biography of mildred taylor literature essays quiz questions major themes characters and a full summary and analysis best summary pdf themes and quotes

independent reading a guide to let the circle be unbroken - Aug 15 2023

web introduction independent reading a guide to let the circle be unbroken pdf pdf an independent study guide to reading latin peter v jones 2018 05 10 accompanies the bestselling latin course designed for students learning latin on their own or with limited access to a teacher

*independent reading a guide to let the circle be unbroken* - Jan 28 2022

web jun 4 2023 let the circle be unbroken independent reading a guide to let the circle be unbroken let the circle be unbroken the implications of african read and download independent reading a guide to let the circle be unbroken free

*independent reading a guide to let the circle be unbroken* - Apr 30 2022

web independent reading a guide to let the circle be unbroken what you subsequently to read independent reading a guide to let the circle be unbroken downloaded from openstackstats mirantis com by guest

*let the circle be unbroken lesson plan gradesaver* - Oct 05 2022

web the let the circle be unbroken lesson plan is designed to help teachers and educators plan classroom activities and

instruction best summary pdf themes and quotes more books than sparknotes

**independent reading a guide to let the circle be unbroken** - Jul 14 2023

web unbroken by laura hillenbrand ray moore 2015 11 17 here is everything you need to enhance your understanding of unbroken by laura hillenbrand a brilliant but disturbing biography of louis zamperini whether you are reading the book as an individual as a member of a reading circle or in class this is the guide to help deepen your understanding

*independent reading a guide to let the circle be unbroken* - Sep 04 2022

web jun 15 2023 merely said the independent reading a guide to let the circle be unbroken is globally consistent with any devices to read it is your certainly own grow old to perform examining routine hence straightforward

let the circle be unbroken summary gradesaver - Mar 10 2023

web let the circle be unbroken study guide contains a biography of mildred taylor literature essays quiz questions major themes characters and a full summary and analysis best summary pdf themes and quotes

**independent reading a guide to let the circle be unbroken** - Apr 11 2023

web independent reading a guide to let the circle be unbroken let them be eaten by bears jun 19 2020 get ready to go out and play based on the author s acclaimed integrated outdoor program let them be eaten by bears is peter hoffmeister s inspiring guide to helping kids enjoy nature and appreciate the great outdoors

**let the circle be unbroken teacher guide by novel units** - Nov 06 2022

web jul 15 2019 let the circle be unbroken teacher guide by novel units novel units on amazon com free shipping on qualifying offers let the circle be unbroken teacher guide by novel units download the free kindle app and start reading kindle books instantly on your smartphone tablet or computer no kindle device required