

OPERATOR'S MANUAL

ENGLISH

KUBOTA DIESEL ENGINE

MODELS Z482-E · Z602-E
D662-E · D722-E
D782-E · D902-E

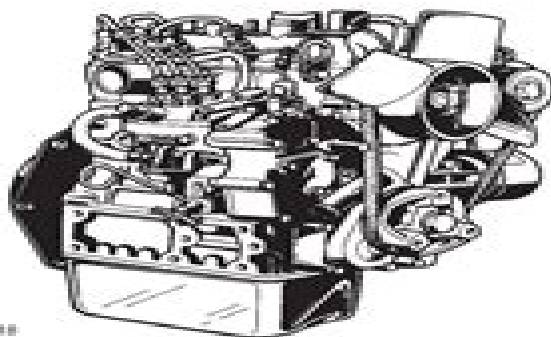

3-1418

16676-8917-1

READ AND SAVE THIS BOOK

Kubota

Kubota D902 Engine Manual

M Carnoy



Kubota D902 Engine Manual:

July 2023 - Surplus Record Machinery & Equipment Directory Tom Scanlan, SURPLUS RECORD is the leading independent business directory of new and used capital equipment machine tools machinery and industrial equipment listing over 110 000 industrial assets since 1924 including metalworking and fabricating machine tools lathes cnc equipment machine centers woodworking equipment food equipment chemical and process equipment cranes air compressors pumps motors circuit breakers generators transformers turbines and more Over 1 100 businesses list with the SURPLUS RECORD July 2023 issue Vol 100 No 7 **Operator's Manual** Kubota Kabushiki Kaisha, Kubota Shop Manual Penton Staff,2000-05-24 Models L175 L210 L225 L225DT L260 Models B5100D B5100E B6100D B6100E B6100HST D B6100HST E B7100D B7100HST D B7100HST E Models L185 L235 L245 L275 L285 L295 L305 L345 L355 **L Type Diesel Engine Repair Manual** Toyota Jidōsha Hanbai Kabushiki Kaisha,1982 *Workshop Manual for the Isuzu Diesel Engine* Isuzu Jidōsha Kabushiki Kaisha,Isuzu Motors,1971 **L Type Diesel Engine Repair Manual** ,1980 **Chilton's Truck Repair Manual** Chilton Book Company. Automotive Editorial Department,1974 **Kubota Tiller Model AD70 Operator's Manual** Kubota, **D.2D Engine Repair Manual** Motor Sales Co Toyota,19?? **Workshop Manual for the Isuzu Diesel Engine** Isuzu Motors,1971 For 6 cylinder trucks produced in 1973 **1991 1/2 Dodge Trucks Diesel Engine Manual Supplement** ,1991 **Technical Manual** Kubota (Firm).,197? *International Engines, Operator's Manual* ,1974 **Motor Truck & Diesel Repair Manual** Louis C. Forier,1974 **2M & M Engine Repair Manual** Toyota Jidōsha Hanbai Kabushiki Kaisha. Export-Technical Dept,Toyota Motor Sales Co. Export-Technical Dept,1967 **Motor Truck & Diesel Repair Manual** Motor (New York, N.Y.),1974 *Maintenance Manual, Toro-flow Diesel Engine* General Motors Corporation. GMC Truck & Coach Division,1964 *Isuzu Workshop Manual* ,1982 Part no C223 WE 141 This manual applies to the 1982 year and later models **Toyota 2A, 3A, 3A-C, 4A, 4A-C, 4A-GE Engine Manual** ,1983 Mazda Diesel Engine (2.2 Liters) Tōyō Kōgyō Kabushiki Kaisha,1981

Immerse yourself in heartwarming tales of love and emotion with its touching creation, **Kubota D902 Engine Manual** . This emotionally charged ebook, available for download in a PDF format (Download in PDF: *), is a celebration of love in all its forms. Download now and let the warmth of these stories envelop your heart.

http://www.armchairempire.com/data/virtual-library/Documents/Hewlett_Packard_Ipaq_Rz1710_Manual.pdf

Table of Contents Kubota D902 Engine Manual

1. Understanding the eBook Kubota D902 Engine Manual
 - The Rise of Digital Reading Kubota D902 Engine Manual
 - Advantages of eBooks Over Traditional Books
2. Identifying Kubota D902 Engine Manual
 - Exploring Different Genres
 - Considering Fiction vs. Non-Fiction
 - Determining Your Reading Goals
3. Choosing the Right eBook Platform
 - Popular eBook Platforms
 - Features to Look for in an Kubota D902 Engine Manual
 - User-Friendly Interface
4. Exploring eBook Recommendations from Kubota D902 Engine Manual
 - Personalized Recommendations
 - Kubota D902 Engine Manual User Reviews and Ratings
 - Kubota D902 Engine Manual and Bestseller Lists
5. Accessing Kubota D902 Engine Manual Free and Paid eBooks
 - Kubota D902 Engine Manual Public Domain eBooks
 - Kubota D902 Engine Manual eBook Subscription Services
 - Kubota D902 Engine Manual Budget-Friendly Options
6. Navigating Kubota D902 Engine Manual eBook Formats

- ePub, PDF, MOBI, and More
 - Kubota D902 Engine Manual Compatibility with Devices
 - Kubota D902 Engine Manual Enhanced eBook Features
7. Enhancing Your Reading Experience
 - Adjustable Fonts and Text Sizes of Kubota D902 Engine Manual
 - Highlighting and Note-Taking Kubota D902 Engine Manual
 - Interactive Elements Kubota D902 Engine Manual
 8. Staying Engaged with Kubota D902 Engine Manual
 - Joining Online Reading Communities
 - Participating in Virtual Book Clubs
 - Following Authors and Publishers Kubota D902 Engine Manual
 9. Balancing eBooks and Physical Books Kubota D902 Engine Manual
 - Benefits of a Digital Library
 - Creating a Diverse Reading Collection Kubota D902 Engine Manual
 10. Overcoming Reading Challenges
 - Dealing with Digital Eye Strain
 - Minimizing Distractions
 - Managing Screen Time
 11. Cultivating a Reading Routine Kubota D902 Engine Manual
 - Setting Reading Goals Kubota D902 Engine Manual
 - Carving Out Dedicated Reading Time
 12. Sourcing Reliable Information of Kubota D902 Engine Manual
 - Fact-Checking eBook Content of Kubota D902 Engine Manual
 - Distinguishing Credible Sources
 13. Promoting Lifelong Learning
 - Utilizing eBooks for Skill Development
 - Exploring Educational eBooks
 14. Embracing eBook Trends
 - Integration of Multimedia Elements
 - Interactive and Gamified eBooks

Kubota D902 Engine Manual Introduction

In today's digital age, the availability of Kubota D902 Engine Manual books and manuals for download has revolutionized the way we access information. Gone are the days of physically flipping through pages and carrying heavy textbooks or manuals. With just a few clicks, we can now access a wealth of knowledge from the comfort of our own homes or on the go. This article will explore the advantages of Kubota D902 Engine Manual books and manuals for download, along with some popular platforms that offer these resources. One of the significant advantages of Kubota D902 Engine Manual books and manuals for download is the cost-saving aspect. Traditional books and manuals can be costly, especially if you need to purchase several of them for educational or professional purposes. By accessing Kubota D902 Engine Manual versions, you eliminate the need to spend money on physical copies. This not only saves you money but also reduces the environmental impact associated with book production and transportation. Furthermore, Kubota D902 Engine Manual books and manuals for download are incredibly convenient. With just a computer or smartphone and an internet connection, you can access a vast library of resources on any subject imaginable. Whether you're a student looking for textbooks, a professional seeking industry-specific manuals, or someone interested in self-improvement, these digital resources provide an efficient and accessible means of acquiring knowledge. Moreover, PDF books and manuals offer a range of benefits compared to other digital formats. PDF files are designed to retain their formatting regardless of the device used to open them. This ensures that the content appears exactly as intended by the author, with no loss of formatting or missing graphics. Additionally, PDF files can be easily annotated, bookmarked, and searched for specific terms, making them highly practical for studying or referencing. When it comes to accessing Kubota D902 Engine Manual books and manuals, several platforms offer an extensive collection of resources. One such platform is Project Gutenberg, a nonprofit organization that provides over 60,000 free eBooks. These books are primarily in the public domain, meaning they can be freely distributed and downloaded. Project Gutenberg offers a wide range of classic literature, making it an excellent resource for literature enthusiasts. Another popular platform for Kubota D902 Engine Manual books and manuals is Open Library. Open Library is an initiative of the Internet Archive, a nonprofit organization dedicated to digitizing cultural artifacts and making them accessible to the public. Open Library hosts millions of books, including both public domain works and contemporary titles. It also allows users to borrow digital copies of certain books for a limited period, similar to a library lending system. Additionally, many universities and educational institutions have their own digital libraries that provide free access to PDF books and manuals. These libraries often offer academic texts, research papers, and technical manuals, making them invaluable resources for students and researchers. Some notable examples include MIT OpenCourseWare, which offers free access to course materials from the Massachusetts Institute of Technology, and the Digital Public Library of America, which provides a vast collection of digitized books and historical documents. In conclusion, Kubota D902 Engine Manual books and manuals for download have transformed the way

we access information. They provide a cost-effective and convenient means of acquiring knowledge, offering the ability to access a vast library of resources at our fingertips. With platforms like Project Gutenberg, Open Library, and various digital libraries offered by educational institutions, we have access to an ever-expanding collection of books and manuals. Whether for educational, professional, or personal purposes, these digital resources serve as valuable tools for continuous learning and self-improvement. So why not take advantage of the vast world of Kubota D902 Engine Manual books and manuals for download and embark on your journey of knowledge?

FAQs About Kubota D902 Engine Manual Books

1. Where can I buy Kubota D902 Engine Manual books? Bookstores: Physical bookstores like Barnes & Noble, Waterstones, and independent local stores. Online Retailers: Amazon, Book Depository, and various online bookstores offer a wide range of books in physical and digital formats.
2. What are the different book formats available? Hardcover: Sturdy and durable, usually more expensive. Paperback: Cheaper, lighter, and more portable than hardcovers. E-books: Digital books available for e-readers like Kindle or software like Apple Books, Kindle, and Google Play Books.
3. How do I choose a Kubota D902 Engine Manual book to read? Genres: Consider the genre you enjoy (fiction, non-fiction, mystery, sci-fi, etc.). Recommendations: Ask friends, join book clubs, or explore online reviews and recommendations. Author: If you like a particular author, you might enjoy more of their work.
4. How do I take care of Kubota D902 Engine Manual books? Storage: Keep them away from direct sunlight and in a dry environment. Handling: Avoid folding pages, use bookmarks, and handle them with clean hands. Cleaning: Gently dust the covers and pages occasionally.
5. Can I borrow books without buying them? Public Libraries: Local libraries offer a wide range of books for borrowing. Book Swaps: Community book exchanges or online platforms where people exchange books.
6. How can I track my reading progress or manage my book collection? Book Tracking Apps: Goodreads, LibraryThing, and Book Catalogue are popular apps for tracking your reading progress and managing book collections. Spreadsheets: You can create your own spreadsheet to track books read, ratings, and other details.
7. What are Kubota D902 Engine Manual audiobooks, and where can I find them? Audiobooks: Audio recordings of books, perfect for listening while commuting or multitasking. Platforms: Audible, LibriVox, and Google Play Books offer a wide selection of audiobooks.

8. How do I support authors or the book industry? Buy Books: Purchase books from authors or independent bookstores. Reviews: Leave reviews on platforms like Goodreads or Amazon. Promotion: Share your favorite books on social media or recommend them to friends.
9. Are there book clubs or reading communities I can join? Local Clubs: Check for local book clubs in libraries or community centers. Online Communities: Platforms like Goodreads have virtual book clubs and discussion groups.
10. Can I read Kubota D902 Engine Manual books for free? Public Domain Books: Many classic books are available for free as they're in the public domain. Free E-books: Some websites offer free e-books legally, like Project Gutenberg or Open Library.

Find Kubota D902 Engine Manual :

hewlett packard ipaq rz1710 manual

[high school peer edit checklist](#)

hija del optimista la 4 ed impedimenta

[hikes in the virginias exploring the appalachian trail](#)

hilux 2015 owners manual

hiding place study guide key

hino diesel engine j08e tm j08e engine service repair manual

[highschool of the dead vol 2](#)

heurtier monoplay duovox p842 francais

himmel die luft zum atmen ebook

hidden message sudoku

high frequency trading and limit order book dynamics

[highway special investigation report medical oversight of noncommercial drivers](#)

hielko van oaltje een roman uit dertiger jaren

highlander service manual 2010

Kubota D902 Engine Manual :

Color Revival 3rd Edition: Understanding ... Color Analysis is the art and science of looking at one's hair, eyes and skin to determine their natural coloring, or 'season'. Color Revival 3rd Edition: Understanding Advanced ... Updated edition of "Color

Revival: Understanding the advanced 12 & 16 season color analysis theory". Color Analysis is the art and science of looking at ... Color Revival 3rd Edition: Understanding Advanced ... Color Revival 3rd Edition: Understanding Advanced Seasonal Color Analysis Theory by Lora Alexander (2014-03-22) on Amazon.com. *FREE* shipping on qualifying ... Color Revival 3rd Edition: Understanding Advanced ... Updated edition of "Color Revival: Understanding the advanced 12 & 16 season color analysis theory." Color Analysis is the art and science of looking at ... Color Revival 3rd Edition: Understanding Advanced ... Home EB-Books Color Revival 3rd Edition: Understanding Advanced Seasonal Color Analysis Theory ; Stock Photo · Cover May Be Different ; ISBN 10: 1478300604 ; ISBN 13 ... Understanding Advanced Color Analysis 4th Ed. ... "Color Revival" is all about Color Analysis. From the simplest concepts to the most complex, you will learn how to use color to look your absolute best. Book: Color Revival by Lora Alexander Sep 8, 2015 — Today, it arrived! The last of the color analysis books I have recently bought. "Color Revival" -- "Understanding advanced color analysis". Understanding the 12 Season Color Analysis System ... Dec 10, 2009 — Easy to understand charts and photos help explain it in its simplest terms. Included are full palettes for each of the 12 seasons, as well as ... Colour Third Edition Colour Third Edition. A workshop for artists, designers ... colour theory and practice to inspire confidence and understanding in anyone working with colour. Financial Reporting, Financial Statement Analysis And ... Access Financial Reporting, Financial Statement Analysis and Valuation 7th Edition solutions now. Our solutions are written by Chegg experts so you can be ... Solution Manual for Financial Reporting ... - Course Hero View Solution Manual for Financial Reporting, Financial Statement Analysis and Valuation A Strategic Pers from ECONO 221 at Università di Roma Tor Vergata. Financial Reporting and Analysis 7th Edition Revsine ... Full download : <http://goo.gl/s7uYSK> Financial Reporting and Analysis 7th Edition Revsine Solutions Manual, 7th Edition, Collins, Financial Reporting and ... Financial Reporting Financial Statement Analysis and ... Apr 10, 2019 — Financial Reporting Financial Statement Analysis and Valuation 7th Edition Whalen Solutions Manual Full Download: <http://alibabadownload.com> ... Solution Manual for Financial Reporting and Analysis 7th ... Solution Manual For Financial Reporting and Analysis 7th Edition by Revsine ... uses of financial statement information (e.g., valuation, credit analysis, and solutions manual, test bank for Financial Reporting ... solutions manual, test bank for Financial Reporting, Financial Statement Analysis and Valuation A Strategic Perspective 7e 7/E 7th edition by James Wahlen ... Solution Manual for Financial Reporting Solution Manual for Financial Reporting Financial Statement Analysis and Valuation 9th Edition by Wahlen - Free download as PDF File (.pdf), ... Epub free Financial reporting statement analysis and ... Apr 10, 2023 — analysis and valuation solution manual. (2023). Business Analysis & Valuation Business Analysis and Evaluation Functional Analysis and. Financial Reporting and Analysis 7th Edi - 2 Financial Analysis financial reporting and analysis 7th edition revsine solutions manual full download: financial. Solution Manual Financial Reporting ... Aug 30, 2018 — Solution Manual Financial Reporting Financial Statement Analysis and Valuation 7th Edition by James M. Whalen. Solution Manual. The Aurora County All-Stars by Wiles, Deborah Book details

· Reading age. 10 - 13 years · Print length. 242 pages · Language. English · Grade level. 5 and up · Lexile measure. 670L · Dimensions. 7.6 x 5 x ... The Aurora County All-Stars "A slow-simmering stew of friendship and betrayal, family love and loyalty, and finding oneself." —School Library Journal. The Aurora County All-Stars by Deborah Wiles Read 189 reviews from the world's largest community for readers. Twelve-year-old House Jackson—star pitcher and team captain of the Aurora County All-Stars... Review of the Day: The Aurora County All-Stars (Part One) Oct 13, 2007 — Now House must find out how to rescue his team from a fate worse than death, all the while unraveling the mystery of his deceased mom and her ... The Aurora County All-Stars - NC Kids Digital Library Levels · Details. Publisher: HarperCollins. Kindle Book Release date: February 16, 2016. OverDrive Read ISBN: 9780547537115. File size: 1968 KB · Creators. The Aurora County All-Stars Using a leisurely storytelling rhythm, the narrator makes listeners feel old friends, taking them along as 12-year-old baseball fanatic House Jackson discovers ... Aurora County All-Stars, The (2009) by Wiles, Deborah The Aurora County All-Stars. ISBN-10: 0152066268. ISBN-13: 9780152066260. Author: Wiles, Deborah Interest Level: 4-8. Publisher: HarperCollins The Aurora County All-Stars by Deborah Wiles Aug 8, 2015 — This story is set in a small town in America. It's the story of a baseball team that wants desperately to win the one and only real game they ... The Aurora County All-Stars Book Review Aug 1, 2007 — Funny, moving, thoughtful small-town life. Read Common Sense Media's The Aurora County All-Stars review, age rating, and parents guide. THE AURORA COUNTY ALL-STARS From award winner Telgemeier (Smile, 2010), a pitch-perfect graphic novel portrayal of a middle school musical, adroitly capturing the drama both on and ...