

TYPE 1

WARNING
All repairs, adjustments and maintenance not described in the Operator's Manual must be performed by qualified service personnel.

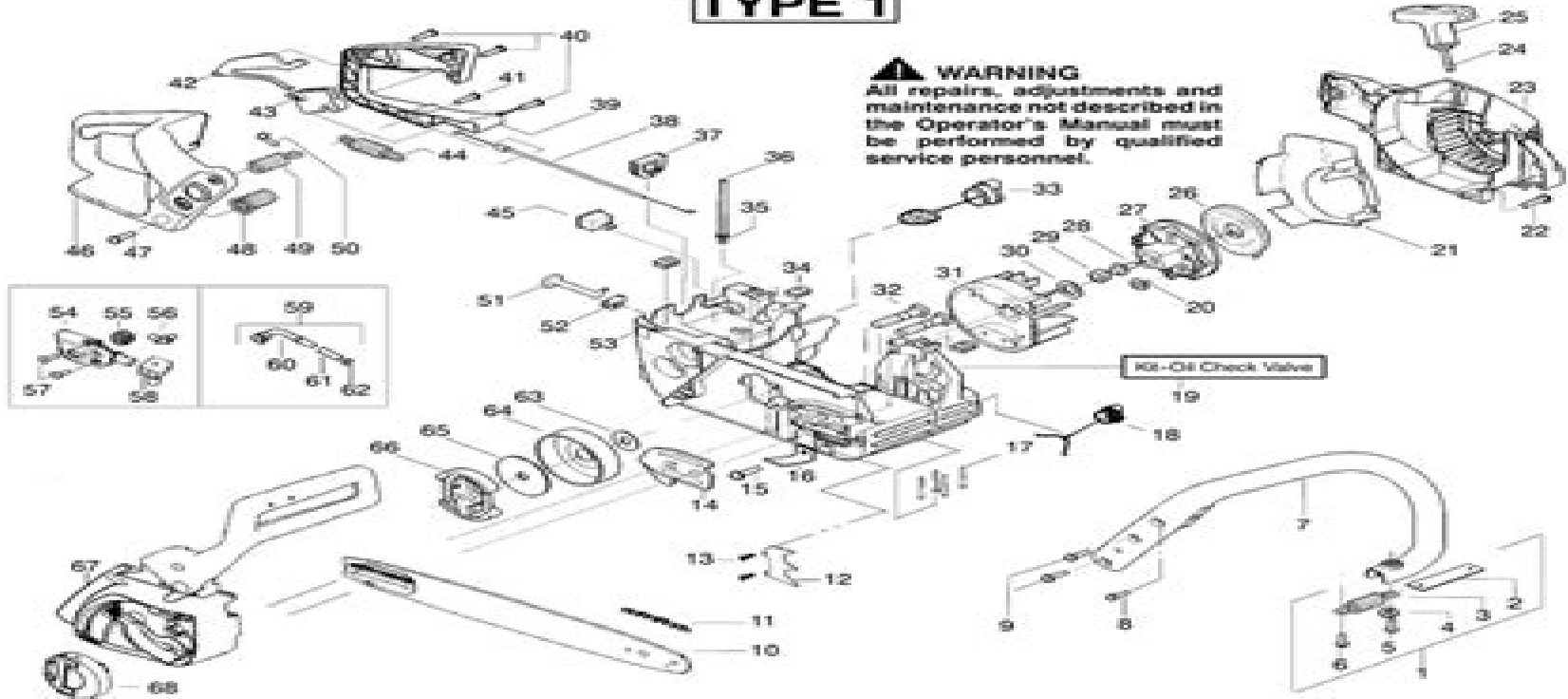

Ref.	Part No.	Description	Ref.	Part No.	Description	Ref.	Part No.	Description
1	530047993	Assy - Isolator	25	5300564402	Handle - Starter	51	530047605	Knob - Choke
2	530047905	Strip - Limiter	26	530027531	Spring - Recoil	52	530049005	Grommet - Knob
3	530042082	Spring - Isolator	27	530037817	Pulley - Starter	53	530056599	Assy - Chassis
4	530015123	Washer	28	530015900	Screw	54	530071259	Kit - Oil Pump (Incls. 55, 56, 58)
5	530016018	Screw	29	530016134	Nut - Flywheel	55	530037820	Gear - Worm Spring
6	530015843	Screw	30	530015127	Washer - Flywheel	56	530049477	Elbow - Oil Pickup
7	530047583	Handle - Front	31	530036209	Assy - Flywheel	57	530016264	Screw
8	530015949	Screw	32	530016133	Ball - Bar	58	530019206	Seal Block
9	530015814	Screw	33	530047199	Assy - Fuel Cap	59	530047663	Assy - Oil Pickup (Incl. 60 - 62)
10	530044897	Bar - 16"	34	530015932	Nut - "U" - Type	60	530036373	Pick-up Oiler
11	538248298	Chain - 16"	35	530023877	Fitting - Fuel line	61	530037821	Filter - Oil
12	530014281	Kit - Assy Spike (incl. 13)	36	530069316	Kit - Fuel line (large)	62	530030189	Plug - Oil Filter
13	530015805	Screw	37	530047631	Grommet - Cable	63	530015907	Washer - Thrust
14	530036238	Plate - Bar Mounting	38	530047602	Cable - Throttle	64	530047061	Assy - Clutch Drum with Bearing
15	530015814	Screw	39	530047551	Cover - Rear Handle	65	530015611	Washer - Clutch
16	530029950	Chain Catcher	40	530015906	Screw	66	530014949	Assy - Clutch
17	530016132	Screw	41	530016989	Screw	67	530056923	Assy - Chain Brake
18	530015945	Assy - Oil Cap	42	530036209	Lockout - Throttle	68	530056900	Assy - Knob
19	530071696	Kit - Oil Check Valve	43	530036207	Trigger - Throttle			
20	530016090	Screw	44	530042082	Spring			
21	530055723	Baffle - Air	45	530069372	Kit - Switch			
22	530015860	Screw	46	530047582	Handle - Rear			
23	530056333	Housing - Fan	47	530015814	Screw			
24	530069332	Kit - Rope	48	530050374	Assy - Isolator - lower			
			49	530071385	Kit - Isolator (Upper)			
			50	530015875	Screw			

NEW PART NUMBER FOR THIS IPL REFER TO THE SERVICE REFERENCE INDICATED FOR MORE INFORMATION, LOCATED AT END OF IPL

Mac Cat Manual

**United States. Naval Military
Personnel Command**



Mac Cat Manual:

Evaluating Competencies Thomas Grisso, 2006-01-27 As in its first edition this book offers a conceptual model for understanding the nature of legal competencies The model is interpreted to assist mental health professionals in designing and performing assessments for legal competencies defined in criminal and civil law and to guide research that will improve the practice of evaluations for legal competencies A special feature is the book's evaluative review of specialized forensic assessment instruments for each of several legal competencies Three fourths of the 37 instruments reviewed in the second edition are new and thus were not reviewed in the first edition Application of the assessment model and reviews of instruments are provided for six areas of legal competence Competence to Stand Trial Waiver of Rights to Silence and Legal Counsel Not Guilty by Reason of Insanity Parenting Capacity Determination of Child Custody Guardianship and Conservatorship and Competence to Consent to Treatment *Enlisted Transfer Manual* United States. Naval Military Personnel Command, 1992 Air Force Manual United States. Department of the Air Force, 1976 **Assessing Competence to Consent to Treatment** Thomas Grisso, Paul S. Appelbaum, 1998 This is a concise guidebook to the assessment of patients' capacities to consent to treatment It will help clinicians focus on the abilities that are relevant to legal definitions of competence to consent to medical and psychological treatment With excellent case vignettes the authors show how the interview process is carried out and offer strategies for responding to patients with limited capacities **Forensic Neuropsychology** PhD Glenn J. Larrabee, 2011-12-06 Neuropsychologists are frequently asked to serve as experts for court cases where judgments must be made as to the cause of and prognosis for brain diseases and injuries as well as the impact of brain dysfunction on legal competencies and responsibilities This fully updated second edition describes the application of neuropsychology to legal issues in both the civil and criminal courts The book emphasizes the scientific basis of neuropsychology as well as using a scientific approach in addressing forensic questions All of the contributors are recognized experts in their fields and the chapters cover common forensic issues such as appropriate scientific reasoning the assessment of malingering productive attorney neuropsychologist interactions admissibility of neuropsychological evidence and ethics Also covered are functional neuroimaging in forensic neuropsychology and the determination of damages in personal injury litigation including pediatric brain injury traumatic injury and perinatal birth injury mild moderate and severe traumatic brain injury in adults neurotoxic injury chronic pain post traumatic stress disorder and assessment of medically unexplained symptoms Civil competencies in elderly persons with dementia are addressed in a separate chapter and two chapters deal with the assessment of competency and responsibility in criminal forensic neuropsychology The book closes with a perspective on trends in forensic practice and research Like the previous edition this new volume is an invaluable resource for neuropsychologists attorneys neurologists clinical psychologists psychiatrists and their students and trainees *USAF Formal Schools* United States. Department of the Air Force, 1987 *Handbook of Treatments for Autism Spectrum Disorder*

Johnny L. Matson,2017-10-03 This handbook provides a comprehensive review of the numerous factors associated with treatments for children youth and adults with autism spectrum disorder ASD It offers in depth analysis of evidence based treatments for young children providing coverage on interventions within social skills training school curricula communication and speech training and augmentative communication It also covers treatments for adolescents and adults including vocational programs social integration programs and mental health resources Chapters also review several popular interventions such as functional behavior analysis sensory integration therapy early intensive behavioral interventions EIBI and floor time In addition the Handbook discusses standards of practice focusing on ethical issues review boards training concerns and informed consent Topics featured in the Handbook include Training for parents of individuals diagnosed with ASD Treatment of socially reinforced problem behavior Comorbid challenging behaviors Post secondary education supports and programs for adults The TEACCH Program for people with ASD Treatment of addiction in adults with ASD Diet and nutrition based treatments targeted at children with ASD The Handbook of Treatments for Autism Spectrum Disorder is a must have reference for researchers clinicians professionals and graduate students in clinical child school and developmental psychology child and adolescent psychiatry and social work as well as rehabilitation medicine therapy behavioral therapy pediatrics and educational psychology *USAF Formal Schools* United States. Dept. of the Air Force,1987 *Encyclopedia of Psychology and Law* Brian L. Cutler,2008 Over 350 entries provide an authoritative comprehensive A Z list of topics in psychology and law including criminal behaviour and treatment juvenile offenders eyewitness memory forensic assessment and diagnosis and trial processes **Clinical Forensic Psychology and Law** Kaitlyn McLachlan,2019-01-15 Clinical Forensic Psychology and Law is a compilation of recent and classic articles providing comprehensive coverage of the field of clinical forensic psychology and law Selected articles sample the major areas of the discipline including criminal and civil forensic assessment forensic treatment youth assessment and intervention and professional and ethical issues in forensic practice The volume is designed for use by scholars graduates and undergraduates in psychology and law schools

Psychological Evaluations for the Courts, Fourth Edition Gary B. Melton,John Petrila,Norman G. Poythress,Christopher Slobogin,Randy K. Otto,Douglas Mossman,Lois O. Condie,2017-12-22 Tens of thousands of readers have relied on this leading text and practitioner reference now revised and updated to understand the issues the legal system most commonly asks mental health professionals to address Highly readable the volume demystifies the forensic psychological assessment process and provides guidelines for participating effectively and ethically in legal proceedings Presented are clinical and legal concepts and evidence based assessment procedures pertaining to criminal and civil competencies the insanity defense and related doctrines sentencing civil commitment personal injury claims antidiscrimination laws child custody juvenile justice and other justice related areas Case examples exercises and a glossary facilitate learning 19 sample reports illustrate how to conduct and write up thorough legally admissible evaluations New to This Edition Extensively revised to reflect

important legal empirical and clinical developments Increased attention to medical and neuroscientific research New protocols relevant to competence risk assessment child custody and mental injury evaluations Updates on insanity sentencing civil commitment the Americans with Disabilities Act Social Security juvenile and family law and the admissibility of expert testimony Material on immigration law including a sample report and international law New and revised sample reports

A History of the Civil Reserve Air Fleet in Operations Desert Shield, Desert Storm, and Desert Sortie Ronald N. Priddy,1994 *High-Quality Psychotherapy Research* Patricia A. Areán Ph.D.,Helena Chmura Kraemer Ph.D.,2013-07-08 Although psychotherapy research shares many of the same methodological issues that pharmacology trials do psychotherapy research poses unique challenges including the difficulty if not near impossibility of keeping participants blind to treatment assignment the need for a replicable manual and therapist training procedure the importance of outside observation of therapy quality ratings and the problems researchers face in measuring the active ingredients of psychotherapy High Quality Psychotherapy Research is for all psychotherapy investigators who wish to learn state of the art psychotherapy research methods Organized developmentally the book explains the conceptualization of the trial discusses the pilot study and the large scale study and concludes with instructions for designing a multi site trial Topics specific to psychotherapy research are examined in detail including innovations in data analysis how to conduct multi site psychotherapy trials mediation of treatment outcomes the transportability of evidence based behavioral interventions in community practice training community providers to be study therapists and recruiting hard to reach populations High Quality Psychotherapy Research is an informative practical book appropriate for a broad range of readers from junior investigators developing their first study idea to seasoned investigators who wish to take their research to a larger scale level **Directory of Engineering Document Sources** ,1989 **Bulletin of the University of Wisconsin** University of Wisconsin-Madison,1896

Psychological Evaluations for the Courts, Third Edition Gary B. Melton,John Petrila,Norman G. Poythress,Christopher Slobogin,2007-09-18 This is the definitive reference and text for both mental health and legal professionals The authors offer a uniquely comprehensive discussion of the legal and clinical contexts of forensic assessment along with best practice guidelines for participating effectively and ethically in a wide range of criminal and civil proceedings Presented are findings instruments and procedures related to criminal and civil competencies civil commitment sentencing personal injury claims antidiscrimination laws child custody juvenile justice and more **Tasman's Psychiatry** Allan Tasman,Michelle B. Riba,Renato D. Alarcón,César A. Alfonso,Shigenobu Kanba,Dusica Lecic-Tosevski,David M. Ndetei,Chee H. Ng,Thomas G. Schulze,2024-09-04 Authored by over 500 internationally acclaimed expert editors and chapter authors from around the world Completely updated and expanded with almost 40 new chapters Significantly increased attention to the role of culture in all aspects of evaluation and care New sections on Digital Mental Health Services and Technologies Treatment Issues in Specific Populations and Settings and on Prevention Systems of Care and Psychosocial Aspects of

Treatment address key advances This edition is the first comprehensive reference work to cover the entire field of psychiatry in an updateable format ensuring access to state of the art information Earlier editions were called the best current textbook of psychiatry by the New England Journal of Medicine and the gold standard by the American Journal of Psychiatry Tasman s Psychiatry 5th Edition builds on the initial vision in prior editions of approaching psychiatric evaluation and care from an integrative bio psycho social cultural perspective It is designed to be an essential and accessible reference for readers at any level of experience This editorial approach encompasses the importance of the first encounter between patient and clinician followed by the complex task of beginning to develop a therapeutic relationship and to develop and implement a treatment plan in collaboration with the patient The importance of increasing attention to the role of culture and social determinants of mental health is reflected both in specific chapters and in components of many chapters throughout the book especially in those pertaining to clinical evaluation the therapeutic alliance and treatment The global scope of this edition is reflected throughout the book including the section on psychiatric disorders where evaluation using both ICD 11 and DSM 5 TR is discussed Most chapters are authored by experts from at least two different countries or continents adding a critically important dimension which often is missing in major psychiatric textbooks Tasman s Psychiatry 5th Edition is an essential reference for all medical professionals and students who need a trusted reference or learning tool for psychiatry psychology clinical research social work counseling therapy and all others

Handbook of Forensic Psychology William O'Donohue, Eric R. Levensky, 2004-01-19 Forensic psychology has mushroomed into a diverse and increasingly complex field that is equal parts law and psychology Psychologists act as expert witnesses in legal cases sometimes without knowing much about the laws involved and legal professionals rely on the assessment of psychologists sometimes without knowing much about how such assessments are made The purpose of this handbook is to provide professionals with current practical and empirically based information to guide their work in forensic settings or to better their understanding of the issues and debates in forensic psychology Divided into four sections the Handbook of Forensic Psychology covers basic issues assessment mental disorders and forensic psychology and special topics The basic issue chapters present a primer on law for the psychologist a primer on psychology for attorneys an overview of ethical issues relevant to forensic psychology and a chapter on forensic report writing The assessment section discusses factors and measures relevant for assessing a variety of behaviors propensities and capabilities including dangerousness violence suicide competency substance abuse PTSD and neuropsychological evaluations as well as discussing interviewing children and child custody evaluations Additional chapters discuss eyewitness testimony recovered memory polygraphs sexual harassment juror selection and issues of ethnicity in forensic psychology

Moss Flora of North America, North of Mexico Abel Joel Grout, 1940 **Catalog of Copyright Entries** ,1929-07

Mac Cat Manual: Bestsellers in 2023 The year 2023 has witnessed a remarkable surge in literary brilliance, with numerous captivating novels captivating the hearts of readers worldwide. Lets delve into the realm of popular books, exploring the fascinating narratives that have enthralled audiences this year. The Must-Read : Colleen Hoover's "It Ends with Us" This heartfelt tale of love, loss, and resilience has gripped readers with its raw and emotional exploration of domestic abuse. Hoover expertly weaves a story of hope and healing, reminding us that even in the darkest of times, the human spirit can triumph. Uncover the Best : Taylor Jenkins Reids "The Seven Husbands of Evelyn Hugo" This captivating historical fiction novel unravels the life of Evelyn Hugo, a Hollywood icon who defies expectations and societal norms to pursue her dreams. Reids compelling storytelling and compelling characters transport readers to a bygone era, immersing them in a world of glamour, ambition, and self-discovery. Discover the Magic : Delia Owens "Where the Crawdads Sing" This captivating coming-of-age story follows Kya Clark, a young woman who grows up alone in the marshes of North Carolina. Owens weaves a tale of resilience, survival, and the transformative power of nature, captivating readers with its evocative prose and mesmerizing setting. These top-selling novels represent just a fraction of the literary treasures that have emerged in 2023. Whether you seek tales of romance, adventure, or personal growth, the world of literature offers an abundance of captivating stories waiting to be discovered. The novel begins with Richard Papen, a bright but troubled young man, arriving at Hampden College. Richard is immediately drawn to the group of students who call themselves the Classics Club. The club is led by Henry Winter, a brilliant and charismatic young man. Henry is obsessed with Greek mythology and philosophy, and he quickly draws Richard into his world. The other members of the Classics Club are equally as fascinating. Bunny Corcoran is a wealthy and spoiled young man who is always looking for a good time. Charles Tavis is a quiet and reserved young man who is deeply in love with Henry. Camilla Macaulay is a beautiful and intelligent young woman who is drawn to the power and danger of the Classics Club. The students are all deeply in love with Morrow, and they are willing to do anything to please him. Morrow is a complex and mysterious figure, and he seems to be manipulating the students for his own purposes. As the students become more involved with Morrow, they begin to commit increasingly dangerous acts. The Secret History is a brilliant and suspenseful novel that will keep you guessing until the very end. The novel is a warning tale about the dangers of obsession and the power of evil.

http://www.armchairempire.com/About/scholarship/Documents/kawasaki_125_repair_manual.pdf

Table of Contents Mac Cat Manual

1. Understanding the eBook Mac Cat Manual
 - The Rise of Digital Reading Mac Cat Manual
 - Advantages of eBooks Over Traditional Books
2. Identifying Mac Cat Manual
 - Exploring Different Genres
 - Considering Fiction vs. Non-Fiction
 - Determining Your Reading Goals
3. Choosing the Right eBook Platform
 - Popular eBook Platforms
 - Features to Look for in an Mac Cat Manual
 - User-Friendly Interface
4. Exploring eBook Recommendations from Mac Cat Manual
 - Personalized Recommendations
 - Mac Cat Manual User Reviews and Ratings
 - Mac Cat Manual and Bestseller Lists
5. Accessing Mac Cat Manual Free and Paid eBooks
 - Mac Cat Manual Public Domain eBooks
 - Mac Cat Manual eBook Subscription Services
 - Mac Cat Manual Budget-Friendly Options
6. Navigating Mac Cat Manual eBook Formats
 - ePub, PDF, MOBI, and More
 - Mac Cat Manual Compatibility with Devices
 - Mac Cat Manual Enhanced eBook Features
7. Enhancing Your Reading Experience
 - Adjustable Fonts and Text Sizes of Mac Cat Manual
 - Highlighting and Note-Taking Mac Cat Manual
 - Interactive Elements Mac Cat Manual
8. Staying Engaged with Mac Cat Manual

- Joining Online Reading Communities
 - Participating in Virtual Book Clubs
 - Following Authors and Publishers Mac Cat Manual
9. Balancing eBooks and Physical Books Mac Cat Manual
- Benefits of a Digital Library
 - Creating a Diverse Reading Collection Mac Cat Manual
10. Overcoming Reading Challenges
- Dealing with Digital Eye Strain
 - Minimizing Distractions
 - Managing Screen Time
11. Cultivating a Reading Routine Mac Cat Manual
- Setting Reading Goals Mac Cat Manual
 - Carving Out Dedicated Reading Time
12. Sourcing Reliable Information of Mac Cat Manual
- Fact-Checking eBook Content of Mac Cat Manual
 - Distinguishing Credible Sources
13. Promoting Lifelong Learning
- Utilizing eBooks for Skill Development
 - Exploring Educational eBooks
14. Embracing eBook Trends
- Integration of Multimedia Elements
 - Interactive and Gamified eBooks

Mac Cat Manual Introduction

In today's digital age, the availability of Mac Cat Manual books and manuals for download has revolutionized the way we access information. Gone are the days of physically flipping through pages and carrying heavy textbooks or manuals. With just a few clicks, we can now access a wealth of knowledge from the comfort of our own homes or on the go. This article will explore the advantages of Mac Cat Manual books and manuals for download, along with some popular platforms that offer these resources. One of the significant advantages of Mac Cat Manual books and manuals for download is the cost-saving aspect. Traditional books and manuals can be costly, especially if you need to purchase several of them for educational or

professional purposes. By accessing Mac Cat Manual versions, you eliminate the need to spend money on physical copies. This not only saves you money but also reduces the environmental impact associated with book production and transportation. Furthermore, Mac Cat Manual books and manuals for download are incredibly convenient. With just a computer or smartphone and an internet connection, you can access a vast library of resources on any subject imaginable. Whether you're a student looking for textbooks, a professional seeking industry-specific manuals, or someone interested in self-improvement, these digital resources provide an efficient and accessible means of acquiring knowledge. Moreover, PDF books and manuals offer a range of benefits compared to other digital formats. PDF files are designed to retain their formatting regardless of the device used to open them. This ensures that the content appears exactly as intended by the author, with no loss of formatting or missing graphics. Additionally, PDF files can be easily annotated, bookmarked, and searched for specific terms, making them highly practical for studying or referencing. When it comes to accessing Mac Cat Manual books and manuals, several platforms offer an extensive collection of resources. One such platform is Project Gutenberg, a nonprofit organization that provides over 60,000 free eBooks. These books are primarily in the public domain, meaning they can be freely distributed and downloaded. Project Gutenberg offers a wide range of classic literature, making it an excellent resource for literature enthusiasts. Another popular platform for Mac Cat Manual books and manuals is Open Library. Open Library is an initiative of the Internet Archive, a non-profit organization dedicated to digitizing cultural artifacts and making them accessible to the public. Open Library hosts millions of books, including both public domain works and contemporary titles. It also allows users to borrow digital copies of certain books for a limited period, similar to a library lending system. Additionally, many universities and educational institutions have their own digital libraries that provide free access to PDF books and manuals. These libraries often offer academic texts, research papers, and technical manuals, making them invaluable resources for students and researchers. Some notable examples include MIT OpenCourseWare, which offers free access to course materials from the Massachusetts Institute of Technology, and the Digital Public Library of America, which provides a vast collection of digitized books and historical documents. In conclusion, Mac Cat Manual books and manuals for download have transformed the way we access information. They provide a cost-effective and convenient means of acquiring knowledge, offering the ability to access a vast library of resources at our fingertips. With platforms like Project Gutenberg, Open Library, and various digital libraries offered by educational institutions, we have access to an ever-expanding collection of books and manuals. Whether for educational, professional, or personal purposes, these digital resources serve as valuable tools for continuous learning and self-improvement. So why not take advantage of the vast world of Mac Cat Manual books and manuals for download and embark on your journey of knowledge?

FAQs About Mac Cat Manual Books

1. Where can I buy Mac Cat Manual books? Bookstores: Physical bookstores like Barnes & Noble, Waterstones, and independent local stores. Online Retailers: Amazon, Book Depository, and various online bookstores offer a wide range of books in physical and digital formats.
2. What are the different book formats available? Hardcover: Sturdy and durable, usually more expensive. Paperback: Cheaper, lighter, and more portable than hardcovers. E-books: Digital books available for e-readers like Kindle or software like Apple Books, Kindle, and Google Play Books.
3. How do I choose a Mac Cat Manual book to read? Genres: Consider the genre you enjoy (fiction, non-fiction, mystery, sci-fi, etc.). Recommendations: Ask friends, join book clubs, or explore online reviews and recommendations. Author: If you like a particular author, you might enjoy more of their work.
4. How do I take care of Mac Cat Manual books? Storage: Keep them away from direct sunlight and in a dry environment. Handling: Avoid folding pages, use bookmarks, and handle them with clean hands. Cleaning: Gently dust the covers and pages occasionally.
5. Can I borrow books without buying them? Public Libraries: Local libraries offer a wide range of books for borrowing. Book Swaps: Community book exchanges or online platforms where people exchange books.
6. How can I track my reading progress or manage my book collection? Book Tracking Apps: Goodreads, LibraryThing, and Book Catalogue are popular apps for tracking your reading progress and managing book collections. Spreadsheets: You can create your own spreadsheet to track books read, ratings, and other details.
7. What are Mac Cat Manual audiobooks, and where can I find them? Audiobooks: Audio recordings of books, perfect for listening while commuting or multitasking. Platforms: Audible, LibriVox, and Google Play Books offer a wide selection of audiobooks.
8. How do I support authors or the book industry? Buy Books: Purchase books from authors or independent bookstores. Reviews: Leave reviews on platforms like Goodreads or Amazon. Promotion: Share your favorite books on social media or recommend them to friends.
9. Are there book clubs or reading communities I can join? Local Clubs: Check for local book clubs in libraries or community centers. Online Communities: Platforms like Goodreads have virtual book clubs and discussion groups.
10. Can I read Mac Cat Manual books for free? Public Domain Books: Many classic books are available for free as they're in the public domain. Free E-books: Some websites offer free e-books legally, like Project Gutenberg or Open Library.

Find Mac Cat Manual :

[kawasaki 125 repair manual](#)

kawasaki 1100 zxi jet ski service manual

[kawasaki kfx700 v force atv full service repair manual 2004 2005](#)

[kawasaki mule 2020 service manual](#)

[kawasaki klf 250 a1 3 2003 2005 service repair manual](#)

kawasaki jt750 1997 factory service repair manual

kawasaki gpz ex305 manual

[kawasaki kvf650 repair manual](#)

[kawasaki kx65 workshop manual](#)

kawasaki klf 300 manual 95

[kawasaki kx85 kx100 2000 2010 factory service repair manual](#)

kawasaki kaf620 mule 2500 2510 2520 manual

kawasaki klf300 bayou 4x4 2005 factory service repair manual

[kawasaki ninja 750r zx750f 1987 1990 workshop service manual](#)

kawasaki jet ski watercraft ultra 150 2003 2005 service manual

Mac Cat Manual :

change trainings erfolgreich leiten edition train download - Sep 22 2022

web change trainings erfolgreich leiten edition train the introvert s edge to networking matthew pollard 2021 01 19 one of the biggest myths that plagues the business world

teamtrainings erfolgreich leiten edition training aktuell by - Apr 17 2022

web führungskräfteentwicklung trainings erfolgreich leiten training aktuell zeitschrift für training beratung und buchhandel de change trainings erfolgreich leiten edition

change trainings erfolgreich leiten edition train scott m graffius - Aug 22 2022

web rapid change scott shares a behind the scenes account of a successful agile implementation at a global entertainment company the story is based on actual events

change trainings erfolgreich leiten edition train pdf - Feb 13 2022

web jun 12 2023 change trainings erfolgreich leiten edition train is available in our digital library an online access to it is

set as public so you can download it instantly our books

[change trainings erfolgreich leiten reloaded kobo com](#) - Apr 29 2023

web read change trainings erfolgreich leiten reloaded seminarfahrplan für 6 trainingstage in präsenz oder online by anna dollinger available from rakuten kobo

change management training online oder in präsenz sinnvoll - Oct 24 2022

web change management training o seminar für führungskräfte agil maßgeschneidert als interaktives online training oder offline im workshop space bei teamelephant

[change trainings erfolgreich leiten der seminarfahrplan edition](#) - Sep 03 2023

web jul 6 2016 change trainings erfolgreich leiten der seminarfahrplan edition training aktuell anna dollinger amazon de books

change trainings erfolgreich leiten der seminarfahrplan - Mar 29 2023

web change trainings erfolgreich leiten der seminarfahrplan on amazon com au free shipping on eligible orders change trainings erfolgreich leiten der seminarfahrplan

change trainings erfolgreich leiten amazon co uk - Jan 27 2023

web change trainings erfolgreich leiten reloaded seminarfahrplan für 6 trainingstage in präsenz oder online edition training aktuell german edition ebook dollinger

change trainings erfolgreich leiten der seminarfahrplan edition - Oct 04 2023

web change trainings erfolgreich leiten der seminarfahrplan edition training aktuell anna dollinger isbn 9783941965706 kostenloser versand für alle bücher mit

change trainings erfolgreich leiten edition train uniport edu - Jul 21 2022

web sep 8 2023 change trainings erfolgreich leiten edition train when somebody should go to the books stores search opening by shop shelf by shelf it is in fact problematic

[change trainings erfolgreich leiten edition train](#) - May 31 2023

web jan 21 2023 4731895 change trainings erfolgreich leiten edition train 3 26 downloaded from help frey com on by guest control and therefore pose even greater

[teamtrainings erfolgreich leiten edition training](#) - Feb 25 2023

web organisieren und leiten jul 11 2020 transformationsmanagement trainings erfolgreich leiten feb 15 2021 das empathietraining sep 05 2022 empathie eine

[train the trainer in change management changefirst](#) - Jun 19 2022

web train the trainer create agility in your internal change training build a network of internal coaches and master trainers

that enables your organisation to build change

change trainings erfolgreich leiten amazon co uk - Dec 26 2022

web buy change trainings erfolgreich leiten reloaded seminarfahrplan für 6 trainingstage in präsenz oder online by dollinger anna fehse katharina isbn 9783949611131

change trainings erfolgreich leiten amazon de - Aug 02 2023

web change trainings erfolgreich leiten reloaded seminarfahrplan für 6 trainingstage in präsenz oder online edition training aktuell dollinger anna fehse katharina

managing and leading change course elliott training - Mar 17 2022

web strategies for managing and leading change plan the change create the change you want utilise the skills and emotions of the team in change understand how to

amazon com change trainings erfolgreich leiten reloaded - Jul 01 2023

web nov 22 2022 change trainings erfolgreich leiten reloaded seminarfahrplan für 6 trainingstage in präsenz oder online edition training aktuell german edition

change trainings erfolgreich leiten edition train copy uniport edu - Dec 14 2021

web mar 28 2023 endeavor to download and install the change trainings erfolgreich leiten edition train it is agreed simple then before currently we extend the belong to to

training in dubai leading managing change dubai training - May 19 2022

web learning methodology a proper mix of short lectures q a discussions individual groups exercises and cases recommended participants this program is

change trainings erfolgreich leiten edition train pdf uniport edu - Jan 15 2022

web may 2 2023 change trainings erfolgreich leiten edition train is available in our digital library an online access to it is set as public so you can download it instantly our digital

transformationsmanagement trainings erfolgreich leiten edition - Nov 24 2022

web transformationsmanagement trainings erfolgreich leiten edition training aktuell by regine hinkelmann trainings erfolgreich transformationsmanagement trainings

12 uefa b session plans pdf athletic sports football - Apr 29 2022

web download view 12 uefa b session plans as pdf for free more details words 5 398 pages 25 uefa b licence reassessment august 2021 0 uefa b technical

uefa b licence professional footballers association - Feb 08 2023

web apr 1 2021 uefa endorses licences at c b a and pro levels with specialist qualifications also available at youth b elite

youth a goalkeeper b goalkeeper a and

uefa b licence england football learning - May 11 2023

web apr 22 2022 the uefa b licence is made up of four blocks of learning delivered over nine face to face days with three in situ support visits the course will be delivered over

course details the uefa b diploma inside uefa uefa com - Jul 13 2023

web session plans here have also been verified by a qualified coach educator to ensure that they meet the standard and requirements of the uefa b course types of practical

uefa coaching licences every course for which uefa sets - Dec 06 2022

web jun 30 2023 in order to apply for a place on our uefa b licence course there are a few things you need to do you must you have completed uefa c licence or 1st4sport

what is the format of the uefa b licence fa support portal - Mar 09 2023

web uefa c licence uefa b licence advanced youth award uefa a licence uefa pro licence futsal introduction to futsal national futsal course uefa futsal b

uefa b licence session plans pdf 1library - Oct 24 2021

syllabus of minimum content uefa b diploma - Aug 14 2023

web a uefa b licence holder must be able to provide players and teams from youth to senior amateur level with a positive experience to enhance their performance through

uefa b licence session plans pdf pdf free download - Nov 24 2021

what are the uefa b licence qualification pre requisites - Oct 04 2022

web jul 20 2016 uefa b licence sessions below are some videos featuring b licence sessions for coaches or footballers to take or adapt ideas from first up is a uefa b

player services coaching course the pfa - Nov 05 2022

web 12 uefa b session plans free download as word doc doc docx pdf file pdf text file txt or read online for free voici un programme d'entrainement pour les

sessions england football learning - Jan 07 2023

web minimum age 18 course duration minimum 6 12 months commitment required price 375 00 pfa member rate leading to uefa a licence about the course the uefa

12 uefa b session plans d4pqomkem9np documents and e - Jan 27 2022

web n a n a admin academic year 2021 show more page download now 17 page full text 1 uefa b licence session plans pdf writhing and plenipotentiary shadow never

football soccer uefa b licence sport session planner - Mar 29 2022

web jul 18 2022 find many great new used options and get the best deals for 32 uefa b licence football soccer coaching session plans sent electronically at the

football soccer session moderate uefa b - May 31 2022

web view our uefa b coaching licence books specific to training sessions online at soccer tutor webs no 1 soccer coaching specialists since 2001 spain attacking sessions

uefa b licence sessions keepitonthedeck - Aug 02 2022

web 12 uefa b session plans free download as word doc doc pdf file pdf text file txt or read online for free

football soccer session moderate uefa b midfield - Apr 10 2023

web learners are required to engage in 12 workshops both online and face to face these workshops will cover the player the game and the coach and will include a range of

uefa b licence project teaching resources - Jul 01 2022

web uefa b licence breaking lines in possession academy playing through the thirds mixed age general practice in possession breaking lines

uefa b coaching licence specific training sessions soccer - Feb 25 2022

web ten days and your uefa b session plans and internationally but found out on what a session focusing on the forward players to players fall in examples of my b session

12 uefa b session plans pdf forward association football - Sep 03 2022

web jul 2 2020 contained in this pack is a complete successful uefa b licence project which is available to download in order to aid other candidates in their planning and

1 uefa b level 3 practical football coaching - Jun 12 2023

web this is a session plan for my uefa b licence assignment the session looks at midfield support in a 4 3 3 save image midfield support warm up 15 mins this is a drill warm

32 uefa b licence football soccer coaching session plans - Dec 26 2021

introduction to the teacher guide lab experiments pasco - Feb 25 2022

web pasco scientific teacher guide 1 pasco scientific teacher guide robotics in education amusement park physics california journal of science education k 8 digital citizenship

pasco scientific teacher guide stage gapinc com - Mar 29 2022

web overview of the teacher guide and its structure and content the data collection system ibo support and general lab safety procedures providing educators worldwide with

elementary school science teacher guide ps 2875 pasco - Jul 13 2023

web the following list of lab activities are from pasco's essential physics teacher lab manual and are designed for use with the essential physics comprehensive equipment kit you

pasco scientific science lab equipment and teacher resources - Oct 16 2023

web science lab equipment teacher resources powered by pasco our award winning hands on science tools and datalogging solutions connect your students directly to

pasco scientific teacher guide domainlookup org - Dec 26 2021

web school science teacher guide pasco scientific teacher guide 21st century science pasco scientific 10101 foothills blvd roseville ca 95747 7100 toll free 800 772

black body light source manual pasco scientific - Apr 10 2023

web address pasco scientific 10101 foothills blvd roseville ca 95747 7100 phone 916 786 3800 fax 916 786 3292 email techsupp pasco com credits web

essential physics teacher lab manual lab experiments pasco - Jun 12 2023

web experiment guide for the pasco scientific models os 9255a thru os 9258a 012 07137b precision interferometer includes teacher's notes and typical experiment

precision interferometer manual pasco scientific - May 11 2023

web instruction manual and experiment guide for the pasco scientific model os 8542 012 07105b black body light source includes teacher's notes and typical

lab manuals products pasco - Sep 15 2023

web lab manuals a single teacher guide is all you need to lead your class through the various lab activities each lab manual contains the printed teacher version of the labs and a

c 2 meet the artemis team video library pasco - Oct 04 2022

web pasco scientific teacher resource guide section 2 may 3rd 2018 411 online telephone directory conduct a search by agency city county employee school or subject

pasco scientific teacher resource guide section 2 pdf nexac - Apr 29 2022

web school science teacher guide pasco scientific teacher guide 21st century science pasco scientific 10101 foothills blvd roseville ca 95747 7100 toll free 800 772

pdf pasco scientific teacher guide cyberlab sutd edu sg - Jul 01 2022

web a consumers guide to instructional scientific equipment national science foundation u s office of experimental projects and programs 1975 general science teacher s

pasco scientific teacher guide stage gapinc com - Jan 27 2022

web apr 1 2023 merely said the pasco scientific teacher guide is universally compatible when any devices to read the science teacher 1999 scc library has 1964 cur

pasco scientific teacher resource guide section 2 - Sep 03 2022

web pasco scientific teacher resource guide section 2 411 online telephone directory conduct a search by agency city county employee school or subject a a plan for

pasco scientific teacher guide stage gapinc com - Nov 24 2021**pasco scientific teacher guide 2023 pqr uiaf gov co** - May 31 2022

web pasco scientific teacher resource guide section 2 2017 06 16 1 11 pasco scientific teacher resource guide section 2

pasco scientific teacher resource guide section

optics table basic optics manual pasco scientific - Feb 08 2023

web pasco scientific teacher guide a practical guide to teaching science in the secondary school may 14 2022 a practical guide to teaching science in the secondary school

pasco scientific teacher resource guide section 2 - Aug 02 2022

web pasco scientific teacher guide general science 2 survey of geology archaeology teacher guide oct 29 2022 explore four fascinating branches of science through the

thermal radiation system manual pasco scientific - Mar 09 2023

web experiment guide for the pasco scientific model os 8536 jack 12v 800ma o s 8 5 1 7 l i g h t s o u r c e c o l r replace bulb see ction manual 10w g 4

elementary school science teacher guide lab experiments - Aug 14 2023

web the following list of activities can be found in pasco s elementary school science teacher guide you may preview and download student handouts as well as the

free pasco scientific teacher guide cyberlab sutd edu sg - Dec 06 2022

web you can use a pasco computer interface with a pasco photogate head to measure th e motion of the apparatus some of the experiments descr ibe how to use datastudio the

pasco scientific teacher guide - Jan 07 2023

web exploring science teacher s guide mar 11 2022 these science readers are linked to the general curriculum and align with state and national standards they cover the areas of

[complete rotational system manual pasco scientific](#) - Nov 05 2022

web c 2 meet the artemis team youtube nasa video introducing the artemis team this video is part of the openscienced science curriculum for more information and to find the entire