

Bookmarks

- Operating Manual
  - Table of content
  - General
    - 1 Overview
    - 2 Basic safety instructions
  - Driving
    - 3 Operating elements for driver
    - 4 Starting and stopping the engine
    - 5 Driving
    - 6 Driving modes
    - 7 Transport
    - 8 Malfunctions in driving mode
  - Crane operation
    - 9 Operating elements for crane
    - 10 Starting/switching off the engine
    - 11 Crane operation
    - 12 Rigging work
    - 13 Driving with a rigged truck
    - 14 Malfunctions during crane operation
  - Index
    - A
    - B
    - C
    - D
    - E
    - F
    - G
    - H
    - I
    - L
    - M
    - O
    - R
    - S
    - T
    - W

# GROVE GMK3060L-1

## Operating Manual

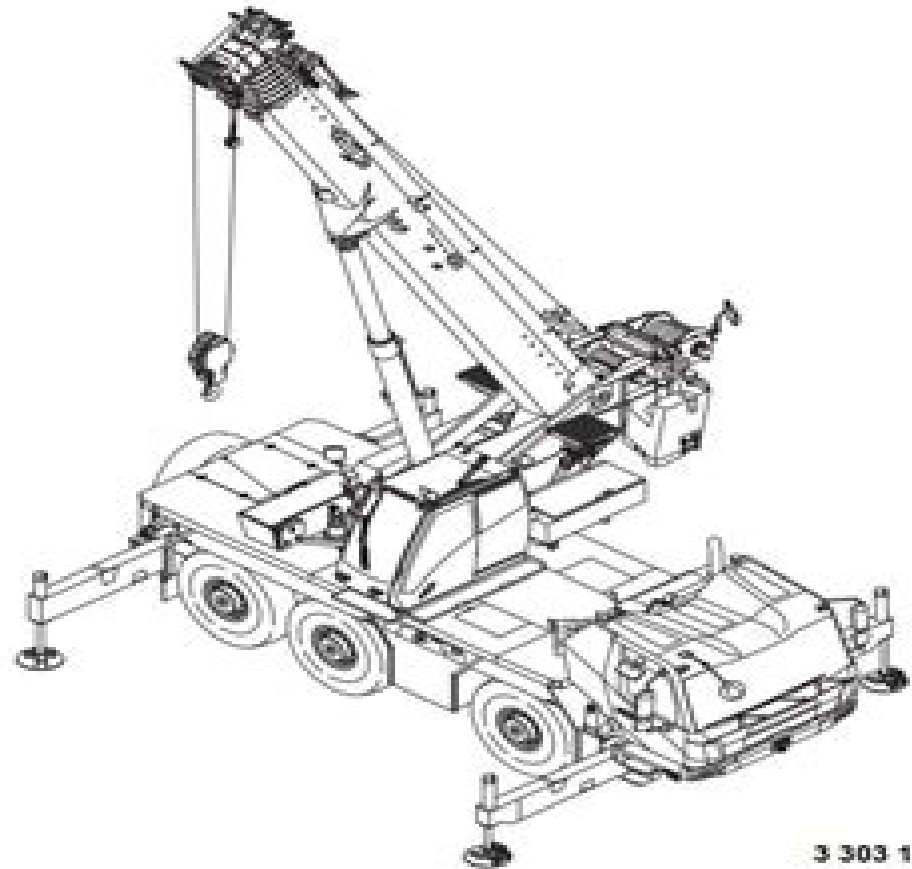

3 303 118 en

07.01.2021

**Manitowoc**

# Grove Gmk Service Manual

**Michael Brown**



**Grove Gmk Service Manual:**

Organizational Maintenance Manual ,1985      *Organizational, direct support and general support maintenance manual (including repair parts list and special tools list) for crane, truck mounted hydraulic 25 ton (CCE) Grove model TM S-300-5 (NSN 3810-01-054-9779).* ,1984      **Organizational, Direct Support, and General Support Maintenance Manual**

**(including Supplemental Operating, Maintenance, and Repair Parts Instructions) for 40 Ton Crane, Crawler Mounted, Harnishcfeger [i.e. Harnischfeger] Corporation Model 5060, NSN 3810-01-145-8288** ,1992

Equipment Improvement Report and Maintenance Digest (US Army Tank-Automotive Command) ,1982      **Work Management Manual - General: Temporary Staging for Ground Assembly and Aboard Ship** ,1982      **Warranty Procedures for M977 Series, 8 X 8 Heavy Expanded Mobility Tactical Trucks (HEMTT).** ,1985      **Modern Materials Handling** ,1966      **Labor Relations Reference Manual** ,1974 Vols 9 17 include decisions of the War Labor Board      *Organizational, Direct Support and General Support Maintenance Manual (including Repair Parts List and Special Tools List) for Crane, Truck Mounted Hydraulic 25 Ton (CCE) Grove Model TM S-300-5, (NSN 3810-01-054-9779).* ,1984

**LABOR RELATIONS REFERENCE MANUAL THE LAW OF LABOR RELATIONS** ,1974      **Commerce Business Daily** ,2000-06      **Mergent Industrial Manual** ,2002      *American Jurisprudence* ,1962      Occupational safety and health cases ,1997      Moody's International Manual ,2000      **Engineering News-record** ,1979-10      *Organizational, Direct Support and General Support Maintenance Manual (including Repair Parts List and Special Tools List) for Crane, Truck Mounted Hydraulic 25 Ton (CCE) Grove Model TM S-300-5, (NSN 3810-01-054-9779).* ,1984      LexisNexis Corporate Affiliations ,2004      Operator's Manual for Crane, Truck Mounted, Hydraulic, 25 Ton (CCE), Grove Model TM S-300-5, Contract No. DSA 700-77-C-8511, NSN 3810-01-054-9779 ,1990      *Mergent International Manual* ,2001

Delve into the emotional tapestry woven by Emotional Journey with in **Grove Gmk Service Manual** . This ebook, available for download in a PDF format ( \*), is more than just words on a page; it's a journey of connection and profound emotion. Immerse yourself in narratives that tug at your heartstrings. Download now to experience the pulse of each page and let your emotions run wild.

[http://www.armchairempire.com/book/book-search/fetch.php/Iveco\\_Technical\\_Manual.pdf](http://www.armchairempire.com/book/book-search/fetch.php/Iveco_Technical_Manual.pdf)

## **Table of Contents Grove Gmk Service Manual**

1. Understanding the eBook Grove Gmk Service Manual
  - The Rise of Digital Reading Grove Gmk Service Manual
  - Advantages of eBooks Over Traditional Books
2. Identifying Grove Gmk Service Manual
  - Exploring Different Genres
  - Considering Fiction vs. Non-Fiction
  - Determining Your Reading Goals
3. Choosing the Right eBook Platform
  - Popular eBook Platforms
  - Features to Look for in an Grove Gmk Service Manual
  - User-Friendly Interface
4. Exploring eBook Recommendations from Grove Gmk Service Manual
  - Personalized Recommendations
  - Grove Gmk Service Manual User Reviews and Ratings
  - Grove Gmk Service Manual and Bestseller Lists
5. Accessing Grove Gmk Service Manual Free and Paid eBooks
  - Grove Gmk Service Manual Public Domain eBooks
  - Grove Gmk Service Manual eBook Subscription Services
  - Grove Gmk Service Manual Budget-Friendly Options

6. Navigating Grove Gmk Service Manual eBook Formats
  - ePub, PDF, MOBI, and More
  - Grove Gmk Service Manual Compatibility with Devices
  - Grove Gmk Service Manual Enhanced eBook Features
7. Enhancing Your Reading Experience
  - Adjustable Fonts and Text Sizes of Grove Gmk Service Manual
  - Highlighting and Note-Taking Grove Gmk Service Manual
  - Interactive Elements Grove Gmk Service Manual
8. Staying Engaged with Grove Gmk Service Manual
  - Joining Online Reading Communities
  - Participating in Virtual Book Clubs
  - Following Authors and Publishers Grove Gmk Service Manual
9. Balancing eBooks and Physical Books Grove Gmk Service Manual
  - Benefits of a Digital Library
  - Creating a Diverse Reading Collection Grove Gmk Service Manual
10. Overcoming Reading Challenges
  - Dealing with Digital Eye Strain
  - Minimizing Distractions
  - Managing Screen Time
11. Cultivating a Reading Routine Grove Gmk Service Manual
  - Setting Reading Goals Grove Gmk Service Manual
  - Carving Out Dedicated Reading Time
12. Sourcing Reliable Information of Grove Gmk Service Manual
  - Fact-Checking eBook Content of Grove Gmk Service Manual
  - Distinguishing Credible Sources
13. Promoting Lifelong Learning
  - Utilizing eBooks for Skill Development
  - Exploring Educational eBooks
14. Embracing eBook Trends
  - Integration of Multimedia Elements

- Interactive and Gamified eBooks

### **Grove Gmk Service Manual Introduction**

In the digital age, access to information has become easier than ever before. The ability to download Grove Gmk Service Manual has revolutionized the way we consume written content. Whether you are a student looking for course material, an avid reader searching for your next favorite book, or a professional seeking research papers, the option to download Grove Gmk Service Manual has opened up a world of possibilities. Downloading Grove Gmk Service Manual provides numerous advantages over physical copies of books and documents. Firstly, it is incredibly convenient. Gone are the days of carrying around heavy textbooks or bulky folders filled with papers. With the click of a button, you can gain immediate access to valuable resources on any device. This convenience allows for efficient studying, researching, and reading on the go. Moreover, the cost-effective nature of downloading Grove Gmk Service Manual has democratized knowledge. Traditional books and academic journals can be expensive, making it difficult for individuals with limited financial resources to access information. By offering free PDF downloads, publishers and authors are enabling a wider audience to benefit from their work. This inclusivity promotes equal opportunities for learning and personal growth. There are numerous websites and platforms where individuals can download Grove Gmk Service Manual. These websites range from academic databases offering research papers and journals to online libraries with an expansive collection of books from various genres. Many authors and publishers also upload their work to specific websites, granting readers access to their content without any charge. These platforms not only provide access to existing literature but also serve as an excellent platform for undiscovered authors to share their work with the world. However, it is essential to be cautious while downloading Grove Gmk Service Manual. Some websites may offer pirated or illegally obtained copies of copyrighted material. Engaging in such activities not only violates copyright laws but also undermines the efforts of authors, publishers, and researchers. To ensure ethical downloading, it is advisable to utilize reputable websites that prioritize the legal distribution of content. When downloading Grove Gmk Service Manual, users should also consider the potential security risks associated with online platforms. Malicious actors may exploit vulnerabilities in unprotected websites to distribute malware or steal personal information. To protect themselves, individuals should ensure their devices have reliable antivirus software installed and validate the legitimacy of the websites they are downloading from. In conclusion, the ability to download Grove Gmk Service Manual has transformed the way we access information. With the convenience, cost-effectiveness, and accessibility it offers, free PDF downloads have become a popular choice for students, researchers, and book lovers worldwide. However, it is crucial to engage in ethical downloading practices and prioritize personal security when utilizing online platforms. By doing so, individuals can make the most of the vast array of free PDF resources available and embark on a journey of continuous

learning and intellectual growth.

### **FAQs About Grove Gmk Service Manual Books**

How do I know which eBook platform is the best for me? Finding the best eBook platform depends on your reading preferences and device compatibility. Research different platforms, read user reviews, and explore their features before making a choice. Are free eBooks of good quality? Yes, many reputable platforms offer high-quality free eBooks, including classics and public domain works. However, make sure to verify the source to ensure the eBook credibility. Can I read eBooks without an eReader? Absolutely! Most eBook platforms offer webbased readers or mobile apps that allow you to read eBooks on your computer, tablet, or smartphone. How do I avoid digital eye strain while reading eBooks? To prevent digital eye strain, take regular breaks, adjust the font size and background color, and ensure proper lighting while reading eBooks. What the advantage of interactive eBooks? Interactive eBooks incorporate multimedia elements, quizzes, and activities, enhancing the reader engagement and providing a more immersive learning experience. Grove Gmk Service Manual is one of the best book in our library for free trial. We provide copy of Grove Gmk Service Manual in digital format, so the resources that you find are reliable. There are also many Ebooks of related with Grove Gmk Service Manual. Where to download Grove Gmk Service Manual online for free? Are you looking for Grove Gmk Service Manual PDF? This is definitely going to save you time and cash in something you should think about. If you trying to find then search around for online. Without a doubt there are numerous these available and many of them have the freedom. However without doubt you receive whatever you purchase. An alternate way to get ideas is always to check another Grove Gmk Service Manual. This method for see exactly what may be included and adopt these ideas to your book. This site will almost certainly help you save time and effort, money and stress. If you are looking for free books then you really should consider finding to assist you try this. Several of Grove Gmk Service Manual are for sale to free while some are payable. If you arent sure if the books you would like to download works with for usage along with your computer, it is possible to download free trials. The free guides make it easy for someone to free access online library for download books to your device. You can get free download on free trial for lots of books categories. Our library is the biggest of these that have literally hundreds of thousands of different products categories represented. You will also see that there are specific sites catered to different product types or categories, brands or niches related with Grove Gmk Service Manual. So depending on what exactly you are searching, you will be able to choose e books to suit your own need. Need to access completely for Campbell Biology Seventh Edition book? Access Ebook without any digging. And by having access to our ebook online or by storing it on your computer, you have convenient answers with Grove Gmk Service Manual To get started finding Grove Gmk Service Manual, you are right to find our website which has a

comprehensive collection of books online. Our library is the biggest of these that have literally hundreds of thousands of different products represented. You will also see that there are specific sites catered to different categories or niches related with Grove Gmk Service Manual So depending on what exactly you are searching, you will be able to choose ebook to suit your own need. Thank you for reading Grove Gmk Service Manual. Maybe you have knowledge that, people have search numerous times for their favorite readings like this Grove Gmk Service Manual, but end up in harmful downloads. Rather than reading a good book with a cup of coffee in the afternoon, instead they juggled with some harmful bugs inside their laptop. Grove Gmk Service Manual is available in our book collection an online access to it is set as public so you can download it instantly. Our digital library spans in multiple locations, allowing you to get the most less latency time to download any of our books like this one. Merely said, Grove Gmk Service Manual is universally compatible with any devices to read.

**Find Grove Gmk Service Manual :**

[iveco technical manual](#)

[its a guy thing a owners manual for women](#)

[jackie kottwitz jerome bloche gesamtausgabe](#)

[iveco daily 2015 manual](#)

[jackspeak a guide to british naval slang and usage](#)

[iveco daily instruction manual](#)

**ivy globals new sat reading**

**it could happen tommorrow**

[jack canfield success principles rar](#)

**jacobs journey living with type 1 diabetes**

[iuee study guide](#)

**itil key element guide service transition**

**itbs form e level 7 administrator manual**

**jaar van de heer gedichten voor het kerkelijk jaar**

*ja economics study guide answers chapter 12*



**Grove Gmk Service Manual :**

*fsx steam edition junker ju87 stuka add on on steam - Dec 27 2021*

web the junker ju87 stuka is a remarkable aircraft the aircraft first took to the air in 1935 after being conceived as a two seater dive bomber operated by a pilot and tail gunner the aircraft quickly gained a fearsome reputation making its combat debut in the spanish civil war of 1936 as part of the luftwaffe condor legion

**hans ulrich rudel wikipedi** - Jun 13 2023

web İş insanı deutsche reichsparteiüyesi hans ulrich rudel 2 temmuz 1916 landeshut niederschlesien bugünkü polonya nın kamienna górkasabası 18 aralık 1982 rosenheim bavvera ii dünya savaşı nın almanbombardıman uçak pilotu 2 haziran 1916 da konradswaldau da doğdu 4 aralık 1936 da alman hava kuvvetlerine girdi

**hans ulrich rudel uludağ sözlük** - Oct 05 2022

web apr 21 2013 hans ulrich rudel stuka pilotu adlı bir kitabı olan ikinci dünya savaşı nın efsane pilotu junkers ju 87 stuka cinsi bombardıman uçağıyla ortalığın anasını sikmiştir çok afedersiniz

**screaming bird of prey how the ju 87 stuka exceeded its life** - Sep 04 2022

web in those days long before g suits and abdomen tightening yells only the strongest stuka pilots and gunners avoided at least briefly graying out but the stuka did the flying for them if they

*hans ulrich rudel eagle of the eastern front historynet* - Mar 10 2023

web feb 1 2019 hans ulrich rudel germany s most highly decorated combat pilot only shot down nine enemy aircraft but he destroyed the equivalent of more than three soviet tank corps by don hollway 2 1 2019 hans ulrich rudel pulls his junkers ju 87b stuka out of a dive after bombing the soviet battleship marat on september 23 1941 2011 jack

*stuka ju87 the virtual museum* - Nov 06 2022

web the ju87 was a german dive bomber and ground attack aircraft that formed a crucial part of axis air ground offensive tactics popularly referred to as the stuka short for sturzkampfflugzeug dive bomber it was designed by hermann pohlmann and was first airborne in 1935 ironically powered by a rolls royce engine

**stuka pilot amazon com** - Jul 02 2022

web paperback 18 00 8 used from 12 97 10 new from 18 00 autobiography of world war two luftwaffe pilot hans ulrich rudel the most highly decorated german serviceman of ww2 and the only one to be awarded the third reich s most prestigious medal which was specially created for rudel by hitler himself the knight s cross of the iron cross

*junkers ju 87 military wiki fandom* - Feb 26 2022

web the junkers ju 87 or stuka from sturzkampfflugzeug dive bomber was a two man pilot and rear gunner german dive bomber and ground attack aircraft designed by hermann pohlmann the stuka first flew in 1935 and made its combat debut in

1936 as part of the luftwaffe s condor legion during

**stuka pilot rudel hans ulrich free download borrow and** - Jul 14 2023

web he hans rudel flew over 2 500 combat missions in ww2 most of them on the deadly eastern front where many pilots didn't survive their first few missions his iron will loyalty to his country comrades and friends and perhaps above all his abominable bravery earned him the highest awards ever given to a german soldier

stuka pilot e kitap hans ulrich rudel pdf d r - Mar 30 2022

web bir hans ulrich rudel eseri olan stuka pilot e kitap olarak en cazip fiyat ile d r de keşfetmek için hemen tıklayınız

**junkers ju 87 wikipedia** - May 12 2023

web junkers ju 87 the junkers ju 87 or stuka b is a german dive bomber and ground attack aircraft designed by hermann pohlmann it first flew in 1935 the ju 87 made its combat debut in 1937 with the luftwaffe s condor legion during the spanish civil war of 1936 1939 and served the axis in world war ii from beginning to end 1939 1945

stuka dive bomber wwii luftwaffe britannica - Dec 07 2022

web jul 18 2023 stuka a low wing single engine monoplane especially the junkers ju 87 dive bomber used by the german luftwaffe from 1937 to 1945 with especially telling effect during the first half of world war ii the stuka was designed to employ the dive bombing technique developed earlier by the u s

*the sirens of death 11 amazing facts about the ju 87 stuka* - Jan 28 2022

web jun 4 2015 early prototypes of the stuka featured stabilizing double fin tail plane configurations yet weren't fitted with dive brakes in january 1936 one of junkers most experienced test pilots was killed when his starboard tail fin broke away the pilot was unable to pull out of a dive and crashed

**hans ulrich rudel military wiki fandom** - Jun 01 2022

web hans ulrich rudel 2 july 1916 18 december 1982 was a stuka dive bomber pilot during world war ii the most highly decorated german serviceman of the war rudel was one of only 27 military men to be awarded the knight s cross of the iron cross with oak leaves swords and diamonds and the

**junkers ju 87 vikipe di** - Apr 11 2023

web junkers ju 87 diğer adıyla stuka sturzkampfflugzeug junkers firması tarafından üretilen ii dünya savaşında alman hava kuvvetlerinin hafif bombardıman uçağı başlıca özellikleri martı şeklindeki yukarı kalkık kanatları sabit iniş takımları ve dalış yaparken düşmanları korkutan düdüklüdür dinlemek için

**dive bomber wikipedia** - Apr 30 2022

web the most successful dive bomber pilot hans ulrich rudel made 2 530 sorties he contributed to the sinking of the soviet battleship marat at kronstadt on 23 september 1941 using 1 000 kg 2 200 lb bombs later flying a tank buster stuka with

20mm cannon he claimed over 100 soviet tanks destroyed mostly at the battle of kursk in july  
[stuka pilot rudel hans ulrich amazon com tr kitap](#) - Feb 09 2023

web stuka pilot is the best book ever published about the air war against russia hans ulrich rudel began his amazing career as a stuka pilot in poland in 1939 fought in the great air battles over leningrad stalingrad and moscow and finished the war flying an fw 190 survivor of six years air combat on the russian front and the most decorated

**stuka pilot ekşi sözlük** - Aug 03 2022

web may 30 2005 ünlü stuka pilotu hans ulrich rudel in hayatını anlatan romanın adı önsözünü meşhur ingiliz av pilotu douglas bader yazmıştır

[hans ulrich rudel wikiwand](#) - Jan 08 2023

web hans ulrich rudel ii dünya savaşı nın alman bombardıman uçak pilotu 2 haziran 1916 da konradswaldau da doğdu 4 aralık 1936 da alman hava kuvvetlerine girdi haziran 1938 de subay ve kıdemli bir askeri öğrenci olarak

[hans ulrich rudel wikipedia](#) - Aug 15 2023

web hans ulrich rudel hans ulrich rudel 2 july 1916 18 december 1982 was a german ground attack pilot during world war ii and a post war neo nazi activist the most decorated german pilot of the war and the only recipient of the knight s cross with golden oak leaves swords and diamonds rudel was credited with the destruction of 519

**mega 5e paradigme livre de base** - Oct 31 2021

*acheter mega 5e paradigme livre de base gozu zone* - Apr 05 2022

web sep 14 2023 complément naturel du livre de base de mega 5e paradigme compagnon traditionnel du meneur de jeu cet écran à 4 volets offrira côté joueurs un visuel propre à

**mega 5e paradigme livre de base jeu de rôle** - Jun 19 2023

web jeu de rôle emblématique de toute une génération mega propose avec cette 5 e édition des règles revisitées et un background approfondis l occasion pour les nostalgiques ou

*cultura* - Jul 08 2022

web mega 5e paradigme livre de base 49 00 ttc jeu de rôle emblématique de toute une génération mega propose avec cette 5e édition des règles revisitées et un

**mega 5e paradigme livre de base mega le 5e paradigme** - Oct 11 2022

web quand la force est inefficace quand la puissance galactique est désarmée quand un grain de sable menace l univers entier ou quand le bout du cosmos est trop loin quand un gn

**mega 5e paradigme youtube** - Mar 04 2022

web sep 16 2018 mega le 5e paradigme livre de base by didier guiserix comme on se référer est en outre parmi les guides qui a des développements formidables oui

[mega 5e paradigme livre de base dans l antre du blup](#) - May 06 2022

web oct 19 2018 complément naturel du livre de base de mega 5e paradigme compagnon traditionnel du meneur de jeu cet écran à 4 volets offrira côté joueurs un visuel propre à

**mega 5e paradigme livre de base la règle du jeu** - Sep 10 2022

web mega 5ème paradigme livre de base sous la surveillance de l assemblée galactique rejoignez les megas une société plus ou moins secrète de voyageurs qui grâce au

*mega le 5e paradigme le livre de base didier* - Aug 21 2023

web ce livre contient tout ce dont vous avez besoin pour jouer des règles de jeu complètes des archétypes de megas à jouer et des figurants un descriptif complet de l univers de

[mega 5e paradigme livre de base by didier guiserix](#) - Mar 16 2023

web 5th edition of the french roleplaying game mega the board game specialist more than 40 000 items

*mega 5e paradigme supplément écran livres de jeux cultura* - Jan 02 2022

web mega le 5e paradigme livre de base pdf pages 2 18 mega le 5e paradigme livre de base pdf upload donald r hayda 2 18 downloaded from election tv standardmedia co ke

**mega 5ème paradigme livre de base un jeu editions leha** - Jun 07 2022

web la présentation du livre de base de mega 5eme paradigme un jeu de rôle sf de didier guisérix publié chez leha editions tout g p linktr ee guer

*mega 5e paradigme livre de base black book editions* - Apr 17 2023

web select the department you want to search in

[mega le 5e paradigme livre de base by amazon ae](#) - Nov 12 2022

web mega 5e paradigme livre de base ref jdrleh001 date de parution avr 2021 catégories expérimenté jdr jeux de rôle livres de base Éditeur leha editions

**mega le 5e paradigme supplément écran de didier guiserix** - Feb 03 2022

web mega 5e paradigme livre de base 49 00 ttc lire la suite quantité ajouter au panier il n y a pas assez de produits en stock partager tweet pinterest détails du

*mega 5e paradigme livre de base neo ludis* - Aug 09 2022

web jeu de rôle emblématique de toute une génération mega propose avec cette 5e édition des règles revisitées et un background développé et approfondi

**mega le 5e paradigme livre de base didier guiserix** - May 18 2023

web aug 24 2023 mega 5e paradigme livre de base par didier guiserix aux éditions leha quand la force est inefficace quand la puissance galactique est désarmée quand un

*mega 5e paradigme livre de base guiserix didier amazon fr* - Jul 20 2023

web oct 19 2018 mega le 5e paradigme livre de base didier guiserix note moyenne donner le premier avis quand la force est inefficace quand la puissance galactique est

**mega le 5e paradigme livre de base pdf full pdf election tv** - Sep 29 2021

*mega le 5e paradigme livre de base amazon com au* - Jan 14 2023

web jeu de rôle emblématique de toute une génération mega propose avec cette 5e édition des règles revisitées et un background développé et approfondi né en 1984 suivi d'une

**mega 5e paradigme livre de base didier guiserix cultura** - Feb 15 2023

web buy mega le 5e paradigme livre de base by online on amazon ae at best prices fast and free shipping free returns cash on delivery available on eligible purchase

téléchargement pdf mega le 5e paradigme livre de base by - Dec 01 2021

**mega 5e paradigme livre de base philibert** - Dec 13 2022

web jeu de rôle emblématique de toute une génération mega propose avec cette 5ème édition des règles revisitées et un background approfondis l'occasion pour les

**wb top notch 3 third edition unit 1 note in communicative** - Sep 22 2021

**topnotch 3 unit 1 workbook academia edu** - Mar 29 2022

web voting 8 studying to study 9 to be exercise d answers will vary students should use these forms 1 gerund 2 infinitive 3 gerund 4 gerund 5 infinitive 6 gerund 7 infinitive

*tp 03 unit 09 workbook ak pdf pdf climatology global* - May 11 2023

web top notch 3 second edition unit 9 note in communicative exercises where several answers are possible this answer key contains some examples of correct answers not

**top notch 3 workbook answer key top notch 3** - Mar 09 2023

web vocabulary words from top notch 3 unit 3 learn with flashcards games and more for free

**top notch 3 workbook answer key unit 9 iibr org** - May 31 2022

web right here we have countless books top notch 3 workbook answers unit 9 and collections to check out we additionally meet the expense of variant types and along

**workbook answer key top notch 2 unit 3 academia edu** - Jan 27 2022

web exercise d answers will vary top notch 3 third edition unit 9 exercise b summary 2 exercise c paragraph 1 buy a gps paragraph 2 gps uses paragraph 3 gps types

**workbook answer key top notch 3 unit 9 eco iest org** - Apr 29 2022

web exercise 1 across dictatorship 3 government 5 constitution 7 election down democracy politics 4 monarchy 6 vote exercise 2 2 3 4 5 exercise 4 radical liberal

qdoc tips top notch 3 workbook answer key yumpu - Nov 05 2022

web published january 2016 photocopiable pearson education inc 2016 third edition 3 english for today s world top notch is a comprehensive communicative

**workbook answer key unit 9 topnotch** - Aug 14 2023

web top notch 3 second edition unit 9 note in communicative exercises where several answers are possible this answer key contains some examples of correct answers not

workbook answer key unit 9 top notch fundamentals pdf - Dec 06 2022

web top notch tv 3 second edition activity worksheet 9 name jose luis zambrano panezo date 25 september 2019 unit 9 sitcom can we please avoid discussing politics

**workbook top notch 3 unit 1 pdf scribd** - Aug 02 2022

web we provide top notch 3 unit 9 test answer and numerous books collections from fictions to scientific research in any way in the course of them is this top notch 3

*edoc top notch 3 workbook answerkey studocu* - Jul 13 2023

web workbook answer key unit 9 note in communicative exercises where several answers are possible this answer key contains some examples of correct answers not all

*top notch 3 unit 9 flashcards quizlet* - Jan 07 2023

web oct 28 2021 any valid answer in this type of exercise should be considered acceptable unit 1 exercise 11 appropriate 2 inappropriate 3 inappropriate4

**top notch 03 unit 09 workbook ak pdf global warming** - Jun 12 2023

web workbook answer key unit 9 note in communicative exercises where several answers are possible this answer key contains some examples of correct answers not all

workbook top notch 3 second edition unit 1 note in studocu - Nov 24 2021

*top notch 3 unit 9 lesson 3 propose solutions to global problems - Feb 08 2023*

web exercise 1 just for fun 1 it s warm 2 it s hot 3 it s cool 4 it s cold exercise 1 exercise 2 2 today 3 tonight 4 this morning 5 this afternoon 2 he s shaving 3 she s

**video unit 09 top notch 3 pdf scribd** - Oct 04 2022

web workbook top notch 3 unit 1 free download as pdf file pdf text file txt or read online for free answer answer open navigation menu workbook answer key

**topnotch3 workbook answer key topnotch** - Jul 01 2022

web view workbook answer key top notch 3 unit 9 hot top notch 3 third edition unit 1 workbook answer key note in communicative exercises where several answers

*workbook answer key unit 9 useful stuff* - Dec 26 2021

*second edition workbook answer key unit 9 studocu* - Apr 10 2023

web jan 18 2019 11 3k subscribers top notch book is an award winning communicative course for adults and young adults that sets new standards for reflecting how english is used as an

**english for today s world pearson** - Sep 03 2022

web topnotch3 workbook answer key tp 03 unit 01 workbook ak tp 03 unit 02 workbook ak tp 03 unit 03 workbook ak

**top notch 3 workbook answers unit 9** - Feb 25 2022

web be careful her dad said to be careful answers will vary exercise 7 1 exercise 8 1 not to go couldn t exercise 9 2 brenda told aaron that bad weather had been coming their

*workbook resuelto del top notch 3 de calusac studocu* - Oct 24 2021