

H15B-2
H15B-Plus2

HANIX
Japanese Craftsmanship

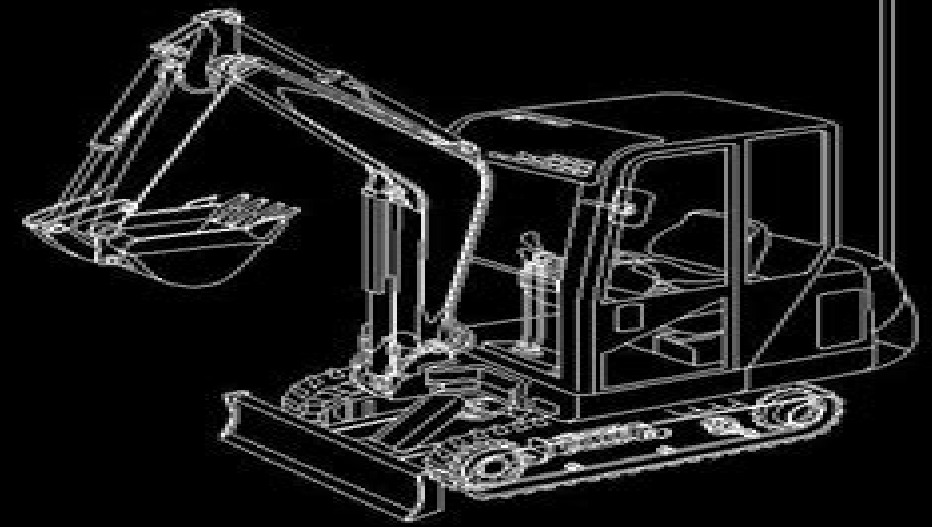

H15B-2
H15B-Plus2

Service Manual

Japanese Craftsmanship

Hanix H15b 2 And H15b Plus 2 Service And Parts Manual

Engine Service Association



Hanix H15b 2 And H15b Plus 2 Service And Parts Manual:

Service Manual and Spare Parts List Electrolux Group,1948 **Service Parts Manual for 1948-1965 Panheads**
,2019-02 Service and parts manual is for 1948 1965 Panhead models Shop book includes service parts and dealer tips for the
models and years that are listed **Parts List and Maintenance Manual** United States. War Dept,1943 **Quick**
Reference Parts Manual Engine Service Association,1976 Instruction Manual and Service Parts List Harnischfeger
Corporation, P & H Diesel Division,1953 **Service and Repair Manual with Illustrated Parts List; Tip Turbine Fan**
Garrett Corporation,Ford Motor Company,Los Angeles (Calif.),1977 Operation, Maintenance, and Repair Parts Manual
Pitman Manufacturing Co,

Decoding **Hanix H15b 2 And H15b Plus 2 Service And Parts Manual**: Revealing the Captivating Potential of Verbal Expression

In an era characterized by interconnectedness and an insatiable thirst for knowledge, the captivating potential of verbal expression has emerged as a formidable force. Its ability to evoke sentiments, stimulate introspection, and incite profound transformations is genuinely awe-inspiring. Within the pages of "**Hanix H15b 2 And H15b Plus 2 Service And Parts Manual**," a mesmerizing literary creation penned with a celebrated wordsmith, readers embark on an enlightening odyssey, unraveling the intricate significance of language and its enduring effect on our lives. In this appraisal, we shall explore the book's central themes, evaluate its distinctive writing style, and gauge its pervasive influence on the hearts and minds of its readership.

http://www.armchairempire.com/results/browse/fetch.php/Mcgraw_Hill_5th_Math.pdf

Table of Contents Hanix H15b 2 And H15b Plus 2 Service And Parts Manual

1. Understanding the eBook Hanix H15b 2 And H15b Plus 2 Service And Parts Manual
 - The Rise of Digital Reading Hanix H15b 2 And H15b Plus 2 Service And Parts Manual
 - Advantages of eBooks Over Traditional Books
2. Identifying Hanix H15b 2 And H15b Plus 2 Service And Parts Manual
 - Exploring Different Genres
 - Considering Fiction vs. Non-Fiction
 - Determining Your Reading Goals
3. Choosing the Right eBook Platform
 - Popular eBook Platforms
 - Features to Look for in an Hanix H15b 2 And H15b Plus 2 Service And Parts Manual
 - User-Friendly Interface
4. Exploring eBook Recommendations from Hanix H15b 2 And H15b Plus 2 Service And Parts Manual
 - Personalized Recommendations

- Hanix H15b 2 And H15b Plus 2 Service And Parts Manual User Reviews and Ratings
- Hanix H15b 2 And H15b Plus 2 Service And Parts Manual and Bestseller Lists
- 5. Accessing Hanix H15b 2 And H15b Plus 2 Service And Parts Manual Free and Paid eBooks
 - Hanix H15b 2 And H15b Plus 2 Service And Parts Manual Public Domain eBooks
 - Hanix H15b 2 And H15b Plus 2 Service And Parts Manual eBook Subscription Services
 - Hanix H15b 2 And H15b Plus 2 Service And Parts Manual Budget-Friendly Options
- 6. Navigating Hanix H15b 2 And H15b Plus 2 Service And Parts Manual eBook Formats
 - ePub, PDF, MOBI, and More
 - Hanix H15b 2 And H15b Plus 2 Service And Parts Manual Compatibility with Devices
 - Hanix H15b 2 And H15b Plus 2 Service And Parts Manual Enhanced eBook Features
- 7. Enhancing Your Reading Experience
 - Adjustable Fonts and Text Sizes of Hanix H15b 2 And H15b Plus 2 Service And Parts Manual
 - Highlighting and Note-Taking Hanix H15b 2 And H15b Plus 2 Service And Parts Manual
 - Interactive Elements Hanix H15b 2 And H15b Plus 2 Service And Parts Manual
- 8. Staying Engaged with Hanix H15b 2 And H15b Plus 2 Service And Parts Manual
 - Joining Online Reading Communities
 - Participating in Virtual Book Clubs
 - Following Authors and Publishers Hanix H15b 2 And H15b Plus 2 Service And Parts Manual
- 9. Balancing eBooks and Physical Books Hanix H15b 2 And H15b Plus 2 Service And Parts Manual
 - Benefits of a Digital Library
 - Creating a Diverse Reading Collection Hanix H15b 2 And H15b Plus 2 Service And Parts Manual
- 10. Overcoming Reading Challenges
 - Dealing with Digital Eye Strain
 - Minimizing Distractions
 - Managing Screen Time
- 11. Cultivating a Reading Routine Hanix H15b 2 And H15b Plus 2 Service And Parts Manual
 - Setting Reading Goals Hanix H15b 2 And H15b Plus 2 Service And Parts Manual
 - Carving Out Dedicated Reading Time
- 12. Sourcing Reliable Information of Hanix H15b 2 And H15b Plus 2 Service And Parts Manual
 - Fact-Checking eBook Content of Hanix H15b 2 And H15b Plus 2 Service And Parts Manual

- Distinguishing Credible Sources
- 13. Promoting Lifelong Learning
 - Utilizing eBooks for Skill Development
 - Exploring Educational eBooks
- 14. Embracing eBook Trends
 - Integration of Multimedia Elements
 - Interactive and Gamified eBooks

Hanix H15b 2 And H15b Plus 2 Service And Parts Manual Introduction

Free PDF Books and Manuals for Download: Unlocking Knowledge at Your Fingertips In today's fast-paced digital age, obtaining valuable knowledge has become easier than ever. Thanks to the internet, a vast array of books and manuals are now available for free download in PDF format. Whether you are a student, professional, or simply an avid reader, this treasure trove of downloadable resources offers a wealth of information, conveniently accessible anytime, anywhere. The advent of online libraries and platforms dedicated to sharing knowledge has revolutionized the way we consume information. No longer confined to physical libraries or bookstores, readers can now access an extensive collection of digital books and manuals with just a few clicks. These resources, available in PDF, Microsoft Word, and PowerPoint formats, cater to a wide range of interests, including literature, technology, science, history, and much more. One notable platform where you can explore and download free Hanix H15b 2 And H15b Plus 2 Service And Parts Manual PDF books and manuals is the internet's largest free library. Hosted online, this catalog compiles a vast assortment of documents, making it a veritable goldmine of knowledge. With its easy-to-use website interface and customizable PDF generator, this platform offers a user-friendly experience, allowing individuals to effortlessly navigate and access the information they seek. The availability of free PDF books and manuals on this platform demonstrates its commitment to democratizing education and empowering individuals with the tools needed to succeed in their chosen fields. It allows anyone, regardless of their background or financial limitations, to expand their horizons and gain insights from experts in various disciplines. One of the most significant advantages of downloading PDF books and manuals lies in their portability. Unlike physical copies, digital books can be stored and carried on a single device, such as a tablet or smartphone, saving valuable space and weight. This convenience makes it possible for readers to have their entire library at their fingertips, whether they are commuting, traveling, or simply enjoying a lazy afternoon at home. Additionally, digital files are easily searchable, enabling readers to locate specific information within seconds. With a few keystrokes, users can search for keywords, topics, or phrases, making research and finding relevant information a breeze. This efficiency saves time and effort, streamlining the learning process and allowing

individuals to focus on extracting the information they need. Furthermore, the availability of free PDF books and manuals fosters a culture of continuous learning. By removing financial barriers, more people can access educational resources and pursue lifelong learning, contributing to personal growth and professional development. This democratization of knowledge promotes intellectual curiosity and empowers individuals to become lifelong learners, promoting progress and innovation in various fields. It is worth noting that while accessing free Hanix H15b 2 And H15b Plus 2 Service And Parts Manual PDF books and manuals is convenient and cost-effective, it is vital to respect copyright laws and intellectual property rights. Platforms offering free downloads often operate within legal boundaries, ensuring that the materials they provide are either in the public domain or authorized for distribution. By adhering to copyright laws, users can enjoy the benefits of free access to knowledge while supporting the authors and publishers who make these resources available. In conclusion, the availability of Hanix H15b 2 And H15b Plus 2 Service And Parts Manual free PDF books and manuals for download has revolutionized the way we access and consume knowledge. With just a few clicks, individuals can explore a vast collection of resources across different disciplines, all free of charge. This accessibility empowers individuals to become lifelong learners, contributing to personal growth, professional development, and the advancement of society as a whole. So why not unlock a world of knowledge today? Start exploring the vast sea of free PDF books and manuals waiting to be discovered right at your fingertips.

FAQs About Hanix H15b 2 And H15b Plus 2 Service And Parts Manual Books

How do I know which eBook platform is the best for me? Finding the best eBook platform depends on your reading preferences and device compatibility. Research different platforms, read user reviews, and explore their features before making a choice. Are free eBooks of good quality? Yes, many reputable platforms offer high-quality free eBooks, including classics and public domain works. However, make sure to verify the source to ensure the eBook credibility. Can I read eBooks without an eReader? Absolutely! Most eBook platforms offer webbased readers or mobile apps that allow you to read eBooks on your computer, tablet, or smartphone. How do I avoid digital eye strain while reading eBooks? To prevent digital eye strain, take regular breaks, adjust the font size and background color, and ensure proper lighting while reading eBooks. What the advantage of interactive eBooks? Interactive eBooks incorporate multimedia elements, quizzes, and activities, enhancing the reader engagement and providing a more immersive learning experience. Hanix H15b 2 And H15b Plus 2 Service And Parts Manual is one of the best book in our library for free trial. We provide copy of Hanix H15b 2 And H15b Plus 2 Service And Parts Manual in digital format, so the resources that you find are reliable. There are also many Ebooks of related with Hanix H15b 2 And H15b Plus 2 Service And Parts Manual. Where to download Hanix H15b 2 And H15b Plus 2

Service And Parts Manual online for free? Are you looking for Hanix H15b 2 And H15b Plus 2 Service And Parts Manual PDF? This is definitely going to save you time and cash in something you should think about. If you trying to find then search around for online. Without a doubt there are numerous these available and many of them have the freedom. However without doubt you receive whatever you purchase. An alternate way to get ideas is always to check another Hanix H15b 2 And H15b Plus 2 Service And Parts Manual. This method for see exactly what may be included and adopt these ideas to your book. This site will almost certainly help you save time and effort, money and stress. If you are looking for free books then you really should consider finding to assist you try this. Several of Hanix H15b 2 And H15b Plus 2 Service And Parts Manual are for sale to free while some are payable. If you arent sure if the books you would like to download works with for usage along with your computer, it is possible to download free trials. The free guides make it easy for someone to free access online library for download books to your device. You can get free download on free trial for lots of books categories. Our library is the biggest of these that have literally hundreds of thousands of different products categories represented. You will also see that there are specific sites catered to different product types or categories, brands or niches related with Hanix H15b 2 And H15b Plus 2 Service And Parts Manual. So depending on what exactly you are searching, you will be able to choose e books to suit your own need. Need to access completely for Campbell Biology Seventh Edition book? Access Ebook without any digging. And by having access to our ebook online or by storing it on your computer, you have convenient answers with Hanix H15b 2 And H15b Plus 2 Service And Parts Manual To get started finding Hanix H15b 2 And H15b Plus 2 Service And Parts Manual, you are right to find our website which has a comprehensive collection of books online. Our library is the biggest of these that have literally hundreds of thousands of different products represented. You will also see that there are specific sites catered to different categories or niches related with Hanix H15b 2 And H15b Plus 2 Service And Parts Manual So depending on what exactly you are searching, you will be able tochoose ebook to suit your own need. Thank you for reading Hanix H15b 2 And H15b Plus 2 Service And Parts Manual. Maybe you have knowledge that, people have search numerous times for their favorite readings like this Hanix H15b 2 And H15b Plus 2 Service And Parts Manual, but end up in harmful downloads. Rather than reading a good book with a cup of coffee in the afternoon, instead they juggled with some harmful bugs inside their laptop. Hanix H15b 2 And H15b Plus 2 Service And Parts Manual is available in our book collection an online access to it is set as public so you can download it instantly. Our digital library spans in multiple locations, allowing you to get the most less latency time to download any of our books like this one. Merely said, Hanix H15b 2 And H15b Plus 2 Service And Parts Manual is universally compatible with any devices to read.

Find Hanix H15b 2 And H15b Plus 2 Service And Parts Manual :

[mcgraw hill 5th math](#)

[megraw hill 4th grade math workbook florida](#)

[mazda verisa manual](#)

[mazda3 repair manuals](#)

[mazda mpv 1989 1998 haynes service & repair manual](#)

[mazrui the power of babel language and governance in the african experience](#)

[mazda mx 5 repair manual](#)

[mcdougal littell high geometry english spanish chapter reviews and tests](#)

mcculloch trimmer manual

[mazda sp20 manual](#)

mcdougal littell mathematics minnesota notetaking guide answer key book 2

mazda mpv owners manual

mbti manual

mcdermott tutorials introductory physics homework solutions

[mccormick ztx230 ztx260 ztx280 tractor operation maintenance service manual 1](#)

Hanix H15b 2 And H15b Plus 2 Service And Parts Manual :

[bongani hospital bursaries for nursing application forms pdf](#) - Mar 30 2022

web bongani hospital nursing bursaries is available in our digital library an online access to it is set as public so you can download it instantly our book servers spans in multiple

bongani hospital nursing bursaries - Jul 02 2022

web jul 29 2023 april 18th 2018 read book online bongani hospital bursaries for nursing download or read online ebook

bongani hospital bursaries for nursing in any

bongani regional hospital nursing school 2022 application - Sep 23 2021

web below is the list of 100 best universities for nursing in turkey ranked based on their research performance a graph of 11 9m citations received by 1 01m academic papers

[bongani hospital nursing bursaries orientation sutd edu](#) - Jun 01 2022

web sep 13 2021 official bongani regional hospital nursing school contact info bongani hospital address mothusi way thabong welkom 9463

[bongani regional hospital nursing school application 2024](#) - Jun 13 2023

the south african nursing council sanc as well as the bongani regional hospital nursing school and midwifery has released the

online admission see more

nursing education in turkey from past to present pubmed - Oct 25 2021

web dec 25 2022 the program is aimed at revolutionizing education in medicine and establishing norms in the field excellence in healthcare is also another goal of the

bongani regional hospital nursing school contact details - Sep 04 2022

web 4 bongani hospital nursing bursaries 2023 06 13 government responses to the events he critically examines the student movement and individual student leaders who

turkey s 100 best nursing universities 2023 rankings - Dec 27 2021

web mar 2 2023 internet in google bing the bongani hospital bursaries for nursing bongani hospital bursaries for nursing application

bongani regional hospital nursing school - May 12 2023

it is recommended that mathematics physical sciences and biology be taken as matriculation subjects candidates shall be admitted to the program if see more

bongani regional hospital nursing school fees 2024 - Mar 10 2023

web jun 10 2020 bongani regional hospital nursing school application 2024 bongani regional hospital nursing school application 2024 bongani regional hospital

bongani regional hospital nursing school scholarships 2022 2023 - Apr 11 2023

web bongani regional hospital nursing school fees 2023 for diplomas certificate post basic and short learning programmes students the official bongani regional hospital

turkish mbbs admissions 2023 2024 medical courses in - Jan 28 2022

web there are several nursing specialties available in postgraduate courses at the master s and doctorate levels including complex health nursing maternal and child health nursing

bongani hospital bursaries for nursing application forms 2022 - Nov 06 2022

web right here we have countless book bongani hospital bursaries for nursing application forms and collections to check out we additionally present variant types and in addition

bongani hospital nursing bursaries - Aug 03 2022

web bongani hospital bursaries for nursing application forms 3 3 report investigates programmes and sites in developing and transitional countries which were regarded by

simplydianeblog - Nov 25 2021

web jul 20 2023 bongani hospital nursing bursaries 1 9 downloaded from uniport edu ng on july 20 2023 by guest bongani

hospital nursing bursaries as recognized

bongani hospital bursaries for nursing application forms - Feb 09 2023

web jun 9 2020 the bongani regional hospital nursing school brhns registration dates 2021 has been announced apply now before the closing dates deadline announced the

bongani hospital bursaries for nursing application forms - Oct 05 2022

web jul 27 2023 bongani hospital bursaries for nursing eventually you will entirely discover a additional experience and execution by spending more cash nevertheless

bongani regional hospital nursing school 2024 - Aug 15 2023

the bongani regional hospital nursing school faculty of health sciences online admission application form 2024 intake application fee courses offered requirements term dates bursaries registration dates registration dates department programmes duration contact address see more

bongani regional hospital nursing school fees 2023 2024 - Jul 14 2023

to qualify as a nurse you can do one of the following 1 a four year bachelor degreein nursing 1 a three year diploma 1 a one year higher certificatein see more

bongani hospital nursing bursaries uniport edu ng - Feb 26 2022

web hospital nursing bursaries of bongani regional hospital nursing school tue 08 may 2018 15 41 00 gmt bongani hospital bursaries for pdf you might be drawn to medicine

bongani hospital nursing bursaries app oaklandlibrary org - Dec 07 2022

web bongani regional hospital nursing school fees structure 2024 below are the prescribed fees for the various undergraduate modules and degrees together with the payment

bongani hospital bursaries for nursing pdf uniport edu - Jan 08 2023

web jan 31 2022 bongani regional hospital nursing school scholarships nsfas application 2022 how to be sure you can get a scholarship make sure you re a full

study of nursing in turkey costs and areas of work - Apr 30 2022

web 4 bongani hospital nursing bursaries 2020 10 24 that are only hinted at from the outside murals mosaics domes galleries stained glass windows gleaming brass and

igcse exam timetable june 2014 hk pdf uniport edu - Feb 09 2023

web igcse exam timetable june 2014 hk is available in our digital library an online access to it is set as public so you can download it instantly our digital library saves in multiple

[igcse exam timetable june 2014 hk pdf download only](#) - May 12 2023

web igcse exam timetable june 2014 hk pdf introduction igcse exam timetable june 2014 hk pdf download only progress in reading literacy in national and international

[hong kong examinations and assessment authority gce - Sep 04 2022](#)

web the international advanced level ial a as level examination offered by pearson edexcel are held in may june and january pearson edexcel is an examining and

[hong kong examinations and assessment authority - Nov 06 2022](#)

web the international general certificate of secondary education igcse examinations offered by pearson edexcel are held in may june and november pearson edexcel is

where can i download examination timetables - Aug 03 2022

web examination timetables for upcoming series can be downloaded from our website here they can also be found in the support materials section of cambridge international

[igcse exam timetable june 2014 hk pdf free devy ortax - Sep 23 2021](#)

web igcse exam timetable june 2014 hk pdf pages 2 20 igcse exam timetable june 2014 hk pdf upload mita a paterson 2 20 downloaded from devy ortax org on september 2

exam timetables cambridge assessment international education - Jun 01 2022

web administrative zone 1 june 2023 timetable zone 1 pdf 724kb november 2023 timetable zone 1 pdf 750kb administrative zone 2 june 2023 timetable zone 2

igcse exam timetable june 2014 hk pdf uniport edu - Apr 11 2023

web may 2 2023 igcse exam timetable june 2014 hk pdf uniport edu ng created date 5 2 2023 2 32 02 pm

[igcse board exam schedule 2024 download exam time table - Dec 27 2021](#)

web step 3 click on exam timetables which is on the left side of the page step 4 scroll down to find the administrative zone 4 in the bottom of the page india comes under

👉👉👉👉👉👉👉👉👉👉 [hkeaa](#) - Jan 28 2022

web 👉👉👉👉👉👉👉👉👉👉 sorry the page you requested cannot be found 👉👉👉👉👉👉👉👉👉👉

igcse exam timetable june 2014 hk banking finance gov - Mar 10 2023

web igcse exam timetable june 2014 hk aqa gcse english language aqa gcse english language student book 1 wjec gcse design and technology wjec gcse history

[igcse exam timetable june 2014 hk 178 128 217 59 - Jan 08 2023](#)

web international schools students who are taking igcse exams in may june 2014 home about contact home all igcse books ymca of hong kong christian college final examinations

igcse exam timetable june 2014 hk 2022 verify meetcircle - Apr 30 2022

web development icmt 2014 ib prepared mathematics applications and interpretations ebook igcse exam timetable june 2014 hk downloaded from verify meetcircle com by guest

international a levels and igcse may june exams hong kong - Nov 25 2021

web full time and part time courses for igcse and international a levels 6 months to 20 months available take all of your edexcel exams at its

igcse exam timetable june 2014 hk pdf free voto uncal edu - Dec 07 2022

web igcse exam timetable june 2014 hk pdf upload dona p hayda 1 4 downloaded from voto uncal edu br on august 27 2023 by dona p hayda igcse exam timetable june

pearson edexcel igcse hkeaa - Jul 02 2022

web the examination timetables are decided by pearson edexcel it is the candidates responsibility to check carefully the relevant examination timetables before submitting

igcse exam timetable june 2014 hk shelagh rixon book - Jun 13 2023

web igcse exam timetable june 2014 hk is available in our book collection an online access to it is set as public so you can get it instantly our digital library hosts in multiple locations

igcse a level exam centre in hong kong latest deadlines - Mar 30 2022

web full time and part time courses for igcse and international a levels 6 months to 20 months available take all of your edexcel exams at its

cambridge final examination timetable june 2014 - Jul 14 2023

web cambridge final examination timetable june 2014 cambridge international general certificate of secondary education igcse

hong kong examinations and assessment authority hkeaa - Aug 15 2023

web exam timetable exam regulations handbook for candidates exam centres list of exam centres sen centres circulars participating schools report on exam

igcse exam timetable june 2014 hk pdf free - Oct 25 2021

web introduction igcse exam timetable june 2014 hk pdf free learning styles and pedagogy in post 16 learning a systematic and critical review frank coffield 2004

icse class 10th time table 2014 examination careerindia - Feb 26 2022

web dec 19 2013 council for the indian school certificate examinations new delhi announces icse class 10th time table for 2014 examination jharkhand board

[igcse exam timetable june 2014 hk pdf uniport edu](#) - Oct 05 2022

web feb 20 2023 igcse exam timetable june 2014 hk 2 11 downloaded from uniport edu ng on february 20 2023 by guest knowledge and pedagogy trust in education and

class 11 chemistry chapter 12 organic chemistry byju s - Nov 11 2022

class 11 chemistry mcqs with answers are provided here for chapter 12 organic chemistry some basic principles and techniques these mcqs are based on cbse board curriculum and correspond to the most recent class 11 chemistry syllabus

[mcq questions for class 11 chemistry chapter 12 organic chemistry](#) - Oct 10 2022

june 13 2023 by raju we have compiled the ncert mcq questions for class 11 chemistry chapter 12 organic chemistry some basic principles and techniques with answers pdf free download covering the entire syllabus practice mcq questions for class 11 chemistry with answers on a daily basis and score well in exams

organic chemistry mcq free pdf objective question answer - Jun 18 2023

oct 16 2023 last updated on oct 13 2023 understanding organic chemistry can be made straightforward and engaging with organic chemistry mcqs covering diverse topics like hydrocarbons functional groups and organic reactions organic chemistry mcqs offer a comprehensive overview of this significant branch of chemistry

[mcq questions for class 11 chemistry chapter 12 organic chemistry](#) - Jun 06 2022

nov 24 2020 check the below ncert mcq questions for class 11 chemistry chapter 12 organic chemistry some basic principles and techniques with answers pdf free download mcq questions for class 11 chemistry with answers

organic chemistry multiple choice questions mcq pdf quiz - Feb 02 2022

class 10 chemistry organic chemistry mcqs questions pdf download mcq as compared to its parent alkane an alkyl radical contains one a less carbon b less hydrogen c more carbon d more hydrogen mcq the rate of reaction of organic compounds is

[class 11 chemistry mcq qualitative analysis of organic](#) - Jul 07 2022

class 11 chemistry mcq organic chemistry quantitative analysis class 11 chemistry mcq s block elements important compounds of calcium class 11 chemistry mcq p block elements important compounds of carbon and silicon important compounds of

[organic chemistry mcq multiple choice questions](#) - Sep 21 2023

1000 mcq on organic chemistry arranged chapterwise start practicing now for exams online tests quizzes interviews organic chemistry mcq pdf covers topics like hydrocarbons organic concepts stereochemistry organic compounds heterocyclic compounds polymerisation biomolecules

[organic chemistry quizzes questions answers proprofs](#) - Apr 16 2023

apr 24 2023 sample question suppose you encounter a chemical formula with h as the cation what do you know about this

compound immediately it is probably an acid it has a 1 charge it is an ionic compound it is a base organic chemistry quiz hydrocarbons organic chemistry quiz hydrocarbons hydrocarbons

[organic chemistry questions pw physics wallah](#) - Dec 12 2022

sep 21 2022 pdf of organic chemistry questions find mcq based organic chemistry questions in pdf form for free download consist of organic chemistry questions from all chapters with answer key

organic chemistry multiple choice questions and answers - Aug 08 2022

unlock test organic chemistry multiple choice questions and answers for competitive exams these short objective type questions with answers are very important for board exams as well as competitive exams like upsc nda ssc etc these short solved questions or quizzes are provided by gkseries

[i multiple choice questions type i byju s](#) - Sep 09 2022

2 the iupac name for is 1 hydroxypentane 1 4 dione 1 4 dioxopentanol 1 carboxybutan 3 one 4 oxopentanoic acid solution option iv is the answer 3 the iupac name for 1 chloro 2 nitro 4 methylbenzene 1 chloro 4 methyl 2 nitrobenzene 2 chloro 1 nitro 5 methylbenzene m nitro p chlorotoluene solution option ii is the answer 4

multiple choice questions oxford university press - Aug 20 2023

molecular structure and shapes of organic molecules chapter 3 organic compounds their functional groups intermolecular interactions and physical properties chapter 4 conformation and strain in molecules chapter 5 conjugation electron delocalization and aromaticity chapter 6 acids and bases chapter 7

1000 multiple choice questions in organic chemistry by organic - Jul 19 2023

multiple choice questions in organic chemistry multiple choice questions usually include a phrase or stem followed by three to five options choices test strategies read the directions carefully know if you are penalized for guessing answer easy questions first answering options improve your odds think critically

organic chemistry mcqs collegedunia - Jan 13 2023

organic molecules in any state solid liquid or gaseous mainly comprise carbon or carbon atoms that can covalently link with four more carbon or hydrogen atoms or occasionally with other atoms such as nitrogen or oxygen and are primarily generated by natural processes in living creatures the best examples of organic molecules generating

inorganic chemistry questions practice questions of inorganic - Mar 03 2022

practice questions on inorganic chemistry q1 what is the chemical formula of diborane what is its structure q2 how many banana bonds are there in diborane q3 what is the hsab principle q4 what is the geometry and shape of the sf 4 molecule q5 what is the hybridization of methane click the pdf to check the answers for practice questions

organic chemistry multiple choice questions and answers - Apr 04 2022

free download in pdf organic chemistry multiple choice questions and answers for competitive exams these short objective type questions with answers are very important for board exams as well as competitive exams like upsc nda ssc etc these short solved questions or quizzes are provided by gkseries p

[organic chemistry mcqs test your knowledge of organic](#) - May 17 2023

following are some of the multiple choice questions on the organic chemistry with answers that will help the students in developing their knowledge organic chemistry mcq 1 which two elements do all organic compounds contain bookmark report carbon and hydrogen carbon and oxygen oxygen and hydrogen carbon and nitrogen 2

organic reactions questions and answers sanfoundry - Feb 14 2023

this set of organic chemistry multiple choice questions answers mcqs focuses on organic reactions 1 identify the one which does not come under the organic addition reaction

[sample exam questions organic chemistry ocr gateway](#) - Mar 15 2023

multiple choice questions are asked as questions often starting with what is or which of these you have four options to choose from in a multiple choice question you must only

[organic chemistry neet practice questions mcqs past year questions](#) - May 05 2022

organic chemistry practice questions mcqs past year questions pyqs ncert questions question bank class 11 and class 12

questions ncert exemplar questions and pdf questions with answers solutions explanations ncert reference and difficulty level